



ORIGINAL <sup>®</sup>  
**euroform W**

Made in Italy since 1965

We furnish and enhance open spaces

Arrediamo e riqualifichiamo spazi aperti

Wir möbilieren und verschönern Freiräume

Nous meublons et réhabilitons les espaces ouverts



# topics

## Company

- 4 philosophy
- 6 customized solutions
- 10 brand quality
- 12 certificates

## Products

- 14 panche in legno | banksysteme in holz | bancs avec assis bois | benches in wood
- 89 panche in ghisa | banksysteme in gusseisen | bancs avec piètements en fonte | benches in cast iron
- 95 panche in metallo | banksysteme in metall | bancs avec assis métal | benches in metal
- 126 panche in acciaio inox | banksysteme in edelstahl | bancs avec inox | benches in stainless steel
- 129 tavoli | tische | tables | tables
- 145 cestini portarifiuti | abfallbehälter | corbeilles | litter bins
- 169 cestini raccolta differenziata | mülltrennbehälter | corbeilles de tri sélectif | waste recycling bin
- 173 contenitore per deiezione canine | hundekotbehälter | corbeilles pour déjections canines | service container for dogs
- 175 portacenere | freiraum aschenbecher | cendries en acier | ashtray
- 179 sistemi per biciclette | fahrradsysteme | rangements pour cycles | bike systems
- 191 sistemi per sbarramento | absperrsysteme | bornes et barrières | barriers
- 203 bacheche | anschlagetafeln | panneau d'affichage | notice boards
- 209 fioriere | bepflanzungssysteme | jardinières | planters
- 218 fontane | brunnen | fontaine | fontain
- 221 sistemi di copertura | überdachungssysteme | systèmes de couverture | roofings
- 238 sistemi pergola | pergolasysteme | systèmes pergolas | pergola systems
- 246 copertura fotovoltaica | solardach | couverture photovoltaïque | photovoltaic roofing

## General information

- 250 designer
- 254 misure basamenti | masse betonfundamente | dimensions dés en béton | concrete dimensions

- 258 **Product index**



more informations:

[www.euroform-w.com](http://www.euroform-w.com)

# philosophy



## Bernhard Winkler

Amministratore delegato  
Geschäftsführer  
Directeur général  
Managing director

Negli ultimi anni abbiamo investito molto tempo, energia e impegno per consolidare e dare vita all'idea di fondo della direzione aziendale di Euroform w di "amministrare secondo il modello dei tre pilastri, ossia contemperando l'aspetto ambientale, la dimensione sociale quella economica".

In molte aziende continua a contare solo il profitto, ma non deve essere così! Pertanto euroform w ha deciso di puntare su un modello economico alternativo che premia il comportamento responsabile e che si concentra sul perseguimento del bene comune anziché del profitto: l'economia del bene comune. Abbiamo bisogno di aziende vincenti perché mostrano un atteggiamento responsabile nei confronti della natura e dell'umanità, verso i dipendenti, i consumatori e il pubblico in generale. L'economia del bene comune presenta i tratti fondamentali di un modello economico alternativo. L'obiettivo è la creazione di un vincolante quadro giuridico di riferimento per un'attività di creazione di valori orientata al bene comune.

Nell'economia del bene comune non è il denaro il parametro di riferimento, ma il bilancio del bene comune, metro di misura di comportamenti umani e sostenibili.

In den letzten Jahren haben wir viel Zeit, Energie und Herzblut investiert um den Grundgedanken der Betriebsführung bei euroform w zu untermauern und zu leben, nämlich „Wirtschaften nach dem sogenannten Dreisäulenprinzip: im Einklang von Umwelt, Sozialem und Ökonomie“.

Nach wie vor zählt in vielen Unternehmen allein der Profit. Doch das kann es nicht sein! Euroform w setzt deshalb auf eine alternative Wirtschaftsordnung, die verantwortliches Handeln belohnt und Gemeinwohl-Streben statt Gewinnstreben in den Mittelpunkt stellt: die Gemeinwohl-Ökonomie. Wir brauchen endlich Unternehmen, die erfolgreich sind, weil sie sich für die Belange der Natur sowie der Menschen – der Mitarbeiter, der Verbraucher und der breiten Öffentlichkeit – verantwortlich zeigen. Die „Gemeinwohl-Ökonomie“ deckt die grundlegenden Elemente einer alternativen Wirtschaftsordnung. Ziel ist die Schaffung eines verbindlichen Rechtsrahmens für gemeinwohl-orientiertes Werteschaffen.

In der Gemeinwohl-Ökonomie muss nicht „letztendlich das Geld“ stimmen, sondern die Gemeinwohl-Bilanz, welche humane und nachhaltige Verhaltensweisen misst.

Ces dernières années, nous avons investi beaucoup de temps, d'énergie et d'engagement afin de consolider et de donner vie à l'idée de fond de la direction d'Euroform w de « administrer selon le modèle de trois piliers, c'est-à-dire en associant l'aspect environnemental, la dimension sociale et celle économique ».

Dans beaucoup d'entreprises seul le profit compte mais il ne doit pas en être ainsi ! C'est pourquoi Euroform a décidé de viser un modèle économique alternatif qui récompense le comportement responsable et qui se concentre sur la quête du bien commun plutôt que du profit : l'économie du bien commun. Nous avons besoin d'entreprises gagnantes qui démontrent un comportement responsable dans les relations à la nature et à l'humanité, envers les salariés, les consommateurs et le public en général. L'économie du bien commun présente les traits fondamentaux d'un modèle économique alternatif. L'objectif est la création d'un cadre juridique de référence contraignant pour une activité de création de valeurs orientée vers le bien commun.

Dans l'économie du bien commun, l'argent n'est pas le paramètre de référence mais le bilan du bien commun, critère de mesure des comportements humains et durables.



In recent years we have invested much time, energy and effort to consolidate and establish the idea that is behind Euroform w management philosophy: "to run the company according to the three-pillar model, that is by balancing the environmental, social and economic aspects".

In many companies, profit is still the only thing that counts, but it should not be so! Euroform w decided to rely on an alternative economic model that rewards responsible behaviour and focuses on the pursuit of common good rather than profit: the economy of common good. We need companies who win because they show a responsible behaviour towards nature and humanity, towards employees, consumers and the public at large. The economy of common good presents the key features of an alternative economic model. The goal is to set up a binding legal framework of reference for the creation of common values targeted at the common good. In the economy of common good the parameter of reference is not money, but the common good balance, as a measure of humane and sustainable behaviour.

„Creare il miglior prodotto riducendo al minimo l’impatto ambientale nel massimo rispetto della società in cui viviamo.“

„Stelle das beste Produkt her, belaste die Umwelt so wenig wie möglich und trage soziale Verantwortung.“

“Créer le meilleur produit en réduisant au minimum l’impact environnemental dans le plus grand respect de la société dans laquelle nous vivons.“

“Build the best product, do the least harm to the environment and take social responsibility.“

# customized solutions

soluzioni su misura | sonderlösungen | produits sur mesure | customized solutions

Sosteniamo e perseguiamo i vostri obiettivi con curiosità, mentalità aperta e creatività! Metteteci alla prova e diciteci quali sono i vostri desideri.

Euroform w è il vostro partner, è la soluzione ai vostri problemi e può accompagnarvi nello sviluppo e nella progettazione di prodotti perfettamente adatti per ambienti esterni. Il nostro compito è quello di sviluppare e progettare spazi esterni godibili e adatti a persone di ogni età. Per noi sono particolarmente importanti il connubio tra la natura e l'uomo, il movimento, la salute, il gioco e la sicurezza. Per questo noi siamo il partner ideale per architetti, progettisti e persone che si occupano di questo.

## FLESSIBILITÀ E CREATIVITÀ

I nostri prodotti sono sinonimo di lunga durata, design raffinato, funzionalità e alto standard qualitativo. E se tra l'attuale gamma dei nostri prodotti non doveste trovare nulla che vi soddisfa, saremo lieti di confrontarci con i vostri obiettivi e i vostri desideri, per dare vita assieme a voi a una nuova idea.

## SOLUZIONI SU MISURA

Elementi di design su misura per l'esterno. Con lo staff di euroform w mettiamo in pratica le vostre idee e i vostri desideri con creatività, rapidità e flessibilità, secondo gli usuali standard aziendali.

## DALL'IDEA ALLA PRODUZIONE

Offriamo pianificazione, progettazione e produzione delle vostre idee e l'installazione finale del prodotto in loco.

Wir unterstützen und verfolgen Ihre Ziele mit Neugier, Offenheit und Kreativität! Stellen Sie uns auf die Probe und teilen Sie uns Ihre Wünsche mit.

Euroform w ist Ihr Partner, Problemlöser, Begleiter bei der Entwicklung und Planung passender und stimmiger Produkte für den Aussenbereich. Unser Auftrag ist es, lebenswerte Aussenbereiche für Alt und Jung zu entwickeln und zu gestalten. Die Verbindung von Natur und Mensch, Bewegung, Gesundheit, Spiel und Sicherheit ist uns dabei besonders wichtig. Hierfür sind wir der Ansprechpartner für Architekten, Planer und Menschen, die sich mit diesem Thema befassen.

## FLEXIBILITÄT UND KREATIVITÄT

Langlebigkeit, raffiniertes Design, Funktionalität und ein hoher Qualitätsstandard stehen für unsere Produkte. Sollte Sie aus der bestehenden Produktpalette dennoch nichts Passendes finden, setzen wir uns gern intensiv mit Ihren Vorstellungen und Wünschen auseinander und entwickeln mit Ihnen zusammen eine neue Idee.

## MAßGESCHNEIDERTE LÖSUNGEN

Maßgeschneiderte Gestaltungselemente für den Außenbereich - wir von euroform w setzen Ihre Visionen und Wünsche kreativ, schnell und flexibel, gemäß den gewohnten euroform w Standards um.

## VON DER IDEE BIS ZUR PRODUKTION

Wir bieten Ihnen die Planung, den Entwurf und die Herstellung Ihrer Idee bis zur abschließenden Installation des Produktes vor Ort.

Nous soutenons et poursuivons vos objectifs avec curiosité, un esprit ouvert et de la créativité ! Testez-nous et dites-nous quels sont vos désirs.

Euroform w est votre partenaire, la solution à vos problèmes et il peut vous accompagner dans votre développement et dans la conception de produits parfaitement adaptés pour des environnements externes. Notre devoir est celui de développer et concevoir des espaces externes agréables pour des personnes de tout âge. Pour nous, l'union entre la nature et l'homme, le mouvement, la santé, le jeu et la sécurité sont particulièrement importants. C'est pour cela que nous sommes le partenaire idéal pour les architectes, les concepteurs et les personnes qui s'occupent de ces domaines.

## FLEXIBILITÉ ET CRÉATIVITÉ

Nos produits sont synonymes de longue durée, de design raffiné, de fonctionnalités et haut standard qualitatif. Et si vous ne deviez pas trouver satisfaction dans notre gamme actuelle de produits, nous serons heureux de nous confronter à vos objectifs et à vos désirs pour donner vie à une nouvelle idée, ensemble.

## SOLUTIONS SUR MESURE

Des éléments de design sur mesure pour l'extérieur. Avec l'équipe d'Euroform w, nous mettons en pratique vos idées et vos désirs avec créativité, rapidité et flexibilité selon les standards habituels de notre entreprise.

## DE L'IDÉE À LA PRODUCTION

Nous proposons la planification, la conception et la production de vos idées et l'installation finale du produit sur site.



We support and pursue your goals with curiosity, open mind and creativity! Put us to the test and tell us what you want.

Euroform w is the solution to your problems, a partner who can work side by side with you to develop and design products ideally suited for outdoor environments. Our task is to develop and design outdoor spaces that are enjoyable and suitable for people of all ages. What is especially important to us is the meeting of man and nature, as well as play, movement, health and safety. That's why we are the ideal partners to architects, designers and anyone who deals with these issues.

#### FLEXIBILITY AND CREATIVITY

Our products are synonymous with durability, sophisticated design, functionality and high quality standards. And if you should not find anything suitable in our existing product range, we will be happy to measure up to your goals and desires, and develop new ideas together with you.

#### CUSTOMIZED SOLUTIONS

Design elements tailored for the outdoors. With the help of our staff at euroform w we bring your ideas and desires to life with creativity, speed and flexibility, according to our usual company standards.

#### FROM IDEA TO PRODUCTION

We offer planning, design and production of your own ideas and final installation of the product on site.



Brunico, Italy



Towers, Didsbury, UK



Wiltener Platzl, Innsbruck, Austria



The Towers Business Park, Didsbury UK



Park Esselunga, Torino, Italy



Rovereto , Italy

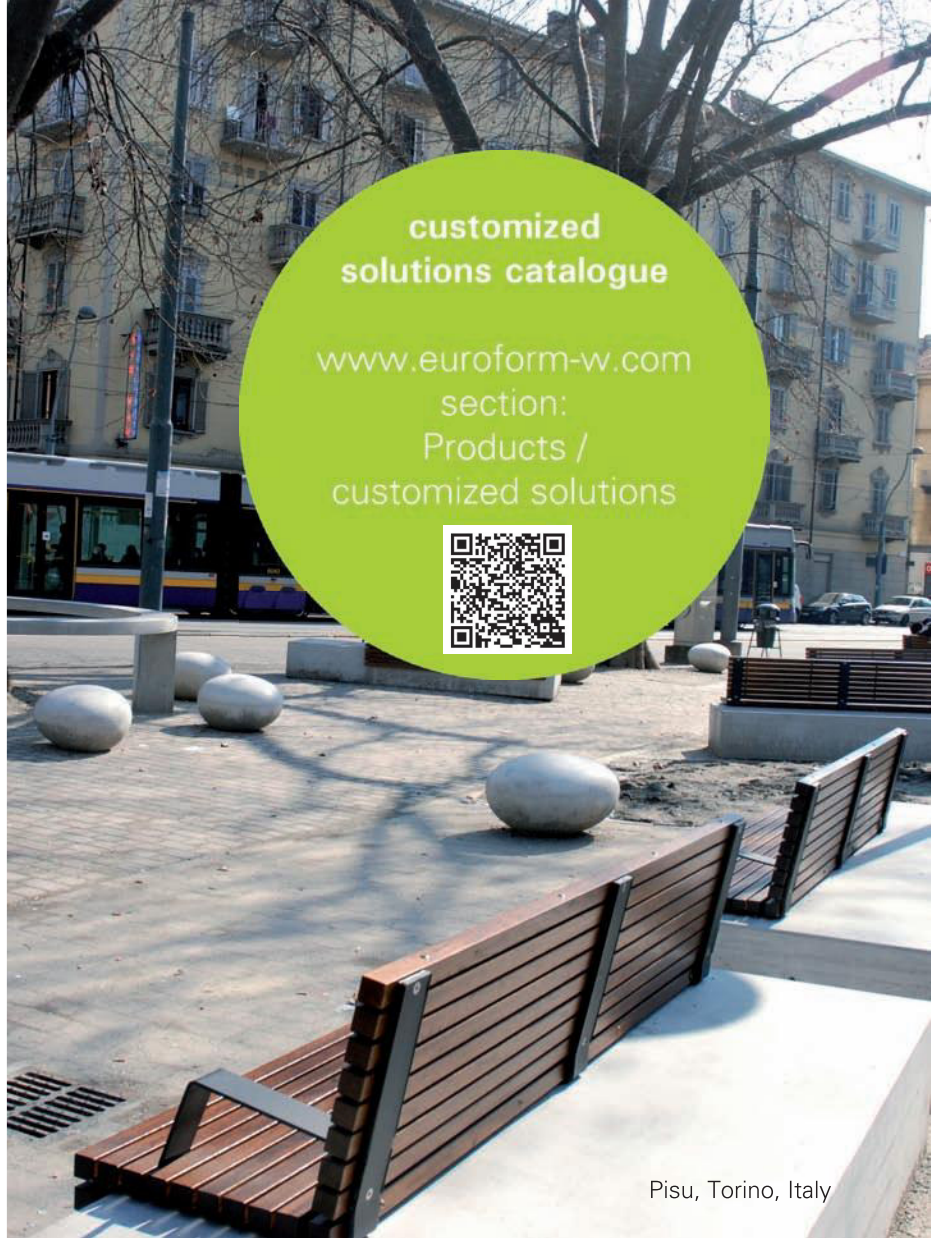

customized  
solutions catalogue

[www.euroform-w.com](http://www.euroform-w.com)  
section:  
Products /  
customized solutions



Pisu, Torino, Italy



Texel, Holland

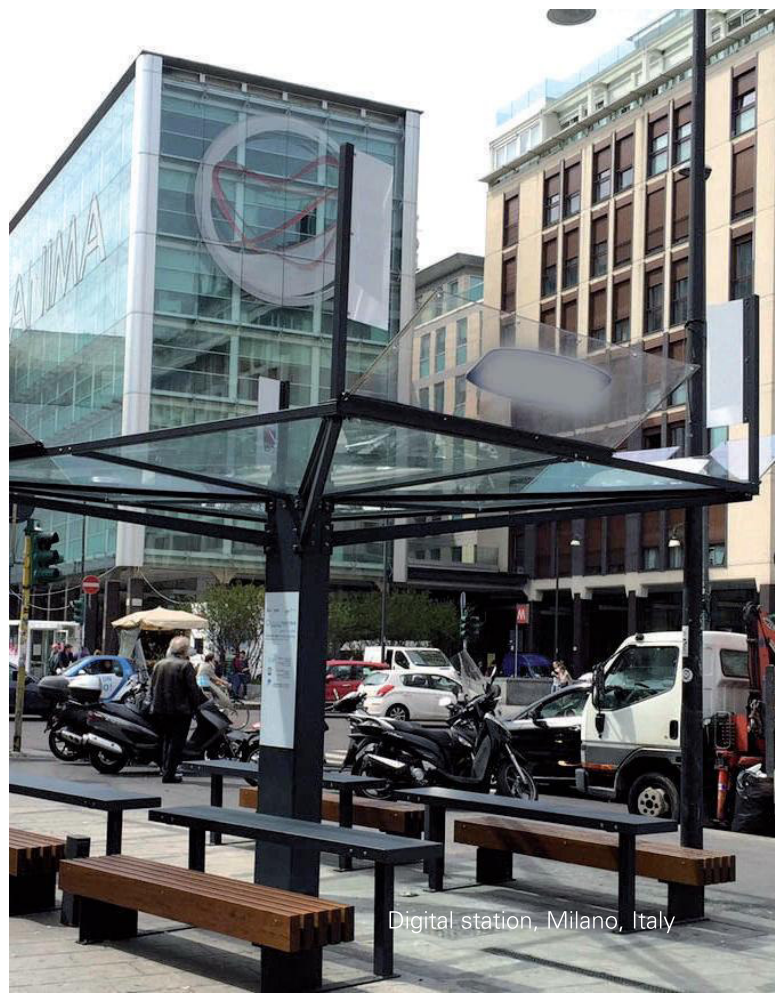

Digital station, Milano, Italy

# brand quality

## Garanzie convincenti

Un buon prodotto deve garantire un'elevata qualità. „euroform w“, grazie all'esperienza pluridecennale ed al costante miglioramento dei processi produttivi e di trattamento dei suoi prodotti di marca offre le seguenti garanzie:

### Legno:

- legni duri – Iroko o simili:  
15 anni anti marcescenza  
senza manutenzione
- legni duri – frassino o simili:  
8 anni anti marcescenza  
con opportuna cura

### Metallo:

- parti zincate a caldo (UNI EN ISO1461):  
10 anni antiruggine
- Parti trattate a polvere:  
6 anni anti sfogliamento  
spessore dello strato di polvere min.  
80 micron 500 h prova a nebbia salina  
a norma  
DIN 50021-SS o ISO 9227  
resistenza ai raggi UV della polvere  
come da tabella di garanzia Qualicoat.

## Überzeugende Garantien

Ein gutes Produkt muss hohe Qualität garantieren. „euroform w“ gibt aufgrund der jahrzehntelangen Erfahrung und der stetigen Verbesserung der Produktionsabläufe und Behandlungsverfahren auf seine Markenprodukte folgende Garantien:

### Holz:

- für Harthölzer wie Kambala (Iroko) o.ä.:  
15 Jahre gegen Verrottung ohne jegliche Wartung
- für Harthölzer wie Esche o.ä.:  
8 Jahre gegen Verrottung  
bei sachgemäßer Pflege

### Metall:

- für feuerverzinkte Teile (UNI EN ISO1461):  
10 Jahre Antirostgarantie
- für pulverbeschichtete Teile:  
6 Jahre Abblätterungsgarantie  
mind. Schichtdicke des Pulvers 80  
Micron 500 h Salzsprühnebeltest lt. DIN  
50021-SS oder ISO 9227 UVBeständigkeit  
des Pulvers lt.  
Garantietabelle Qualicoat.

## Des garanties convaincantes

Un bon produit doit offrir une qualité parfaite. Grâce à une expérience de plusieurs décennies et suite à de constantes améliorations de la chaîne de production, ainsi que du système de traitement sur les différents produits, la gamme „euroform w“ présente les garanties suivantes:

### Bois:

- pour un bois dur comme l'Iroko (ou similaire):  
15 années de garantie contre le pourrissement sans aucun entretien
- pour un bois mi-dur comme le frêne (ou similaire):  
8 année de garantie contre le pourrissement avec un entretien régulier adéquat

### Metal:

- pour les parties galvanisées: 10 années de garantie contre la corrosion
- pour les parties galvanisées et revêtues de poudre polyester cuite au four: 6 années de garantie pour l'adhérence de la poudre.  
Epaisseur de la poudre min. 80 microns  
500 h test de projection de sel selon  
DIN 50021-SS OU ISO 9227. Résistance  
de la poudre aux UV – selon Tableau de  
garantie Qualicoat.

### Impressive guarantees

A good product must guarantee good quality. As a result of its experience gathered over decades, and due to the continuous improvement of production processes and treatment techniques, „euroform w“ is able to offer the following guarantees on its branded products:

#### Wood:

- for hardwoods such as iroko or similar:  
15 years against rotting without any maintenance
- for hardwoods such as ash or similar:  
8 years against rotting with appropriate care

#### Metal:

- for hot-dip galvanized items:  
10 year anti-rust guarantee
- for powder coated items:  
6 year anti-flake guarantee  
min. thickness of powder coating 80 microns. 500 hr salt spray test in accordance with DIN 50021-SS or ISO 9227. UV stability of the powder as detailed in the Qualicoat guarantee table. The afore-mentioned guarantees are conditional upon professional and correct assembly and/or use.



# certificates

## Qualità certificata

euroform w offre qualità organizzativa attraverso sistemi di qualità:

sistema di management di qualità:  
norma ISO-9001 dal 1997

sistema di management ambientale:  
norma ISO-14001 dal 2003

Certificazione FSC dal 2006

CO2 Neutralizzazione dal 2008

Analisi Impronta nel 2011

Certificazione OHSAS 18001 dal 2012

Economia del bene comune dal 2013

## Zertifizierte Qualität

euroform w bietet garantierte Organisationsqualität durch Qualitätssysteme:

Qualitätsmanagementsystem  
gemäß ISO-9001 seit 1997

Umweltmanagementsystem gemäß  
ISO-14001 seit 2003

FSC Zertifizierung seit 2006

CO2 Neutralisierung seit 2008

Footprint Analyse im Jahr 2011

OHSAS 18001 Zertifizierung seit 2012

Gemeinwohloökonomie seit 2013

## Qualité certifiée

euroform w offre une haute qualité d'organisation à travers des systèmes de qualité :

système de gestion de qualité :  
norme ISO-9001 depuis 1997

système de gestion environnementale :  
norme ISO-14001 depuis 2003

Certification FSC depuis 2006

Neutralisation CO2 depuis 2008

Analyse de l'empreinte en 2011

Certification OHSAS 18001 depuis 2012

Économie du bien commun depuis 2013



### Certified quality

euroform w offers guaranteed organization quality thanks to its quality systems:

Quality management system  
in accordance with ISO-9001 since 1997

Environment management  
system in accordance with ISO-  
14001 since 2003

Certification FSC since 2006

CO2 Neutralisation since 2008

Footprint Analysis in 2011

OHSAS 18001 certification since 2012

Economy for the common good since  
2013









# benches in wood

panchine in legno | banksysteme in holz | bancs en bois

Le panchine di euroform w sono sinonimo di stabilità, durata, sicure contro atti di vandalismo e accuratezza nella lavorazione dei dettagli. Ecco perché da oltre 25 anni e più, le nostre panchine si trovano nello stesso luogo. Il design delle nostre panche è cambiato nel corso dei decenni, ma la qualità è rimasta la stessa.

euroform Bänke stehen für Stabilität, Langlebigkeit, Vandalismussicherheit und Genauigkeit in der Verarbeitung der Details. Deshalb stehen unsere Bänke auch schon seit über 25 Jahren und mehr an derselben Stelle. Das Design unserer Bänke hat sich im Laufe der Jahrzehnte verändert, aber die Qualität ist dieselbe geblieben.

Les bancs d'euroform w sont synonyme de stabilité, durée, sûreté contre les actes de vandalisme et précision dans les détails. C'est pourquoi depuis plus de 25 ans, nos bancs se trouvent au même endroit. Le design de nos bancs a changé au cours des décennies, mais la qualité est restée la même.

euroform w bancs stand for stability, durability, vandalism safety and accuracy in the processing of the details. That's why for over 25 years and more, our benches are in the same place. The design of our benches has changed over the decades, but the quality has remained the same.

# legno | holz | bois | wood

## Legno non trattato

I listelli possono essere forniti anche senza velatura superficiale, il legno più indicato, "eurofom w" utilizza per questo solo legno tropicale certificato 100% FSC. Il legno duro come frassino per l'uso all'esterno (se non trattato) non viene consigliato. Le superfici del legno non trattato, con il tempo naturalmente invecchiano: sulla superficie si crea una patina di colore grigio argento che non compromette in nessun modo la sua qualità.

## Legno trattato

I listelli in legno possono essere forniti anche con superficie trattata con velatura a base d'acqua. La rinuncia a sostanze pericolose come metalli pesanti compromette leggermente la durabilità della velatura, rispetto a quanto usavamo fare nel passato. Per preservare la bellezza e l'esperienza di "arredi per esterno realizzati da eurofom w" si consiglia di rinnovare il trattamento del legno dopo il primo inverno e poi almeno ogni due anni.

## Unbehandeltes Holz

Die Holzbelattung kann unbehandelt geliefert werden, wobei sich Esche unbehandelt jedoch nicht für den Außenbereich eignet. Dafür bietet sich Exotenh Holz an. „eurofom w“ verwendet ausschließlich 100% FSC zertifiziertes Tropenholz. Naturbelassenes Hartholz verwittert im Laufe der Zeit: auf der Oberfläche bildet sich eine silbrig graue Patina, die jedoch in keiner Weise die Qualität des Rohstoffes beeinträchtigt.

## Behandeltes Holz

Holzplatten können ab Werk oberflächenbehandelt geliefert werden. Die Behandlung erfolgt mit Dünnschichtlasuren auf Wasserbasis. Der Verzicht auf Inhaltsstoffe wie z.B. Schwermetalle in Lasuren, führt dazu, dass diese generell nicht mehr so lange haltbar sind wie einst. Um die Schönheit und das Erlebnis „Freiraumausstattung mit eurofom w“ zu erhalten, wird empfohlen, nach einer Überwinterung und dann mindestens alle zwei Jahre den Schutzanstrich einer Holzoberfläche zu erneuern und somit der Abwitterung vorzubeugen.

## Bois non traité

Les lattes peuvent également être fournies non traitées, le bois le plus indiqué est l'exotique, « Euroform w » utilise pour cela uniquement du bois tropical certifié 100 % FSC. Le bois dur comme le frêne (si non traité) n'est pas conseillé pour l'utilisation à l'extérieur. Les surfaces du bois non traitées vieillissent naturellement avec le temps : sur la surface, une patine de couleur grise argenté se crée qui ne compromet sa qualité d'aucune manière.

## Bois traité

Les lattes en bois peuvent également être fournies avec des surfaces traitées avec une couche de glacis à base d'eau. L'abandon des substances dangereuses comme les métaux lourds compromet légèrement la durabilité du voile par rapport à autrefois. Pour préserver la beauté et l'expérience des « meubles pour l'extérieur réalisés par Eurofom w », on conseille de renouveler le revêtement du bois après le premier hiver et ensuite au moins tous les deux ans.

## Untreated wood

The slats can be supplied untreated, but it should be taken into account that untreated ash wood is not suitable for outdoor use. Exotic wood is more appropriate for this purpose. "eurofom w" uses only 100% FSC certified tropical wood. After a few months the greying process of the surface of untreated wood sets in. However, this is not a defect and does not affect the stability or quality of the urban furniture.

## Treated wood

Wooden slats can also be supplied surface-treated. Treatment is made with thin water-based glazes. The avoidance of ingredients such as heavy metals in glazes means that those varnishes are generally not as durable as before. To preserve the beauty and the experience of "outdoor furniture made by eurofom w" it is recommended to renew the protective coating of a wooden surface after the first winter and then at least every two years to prevent weathering.

## lineaseduta

mod. 375



Peso | Gewicht | Poids | Weight: 89 kg

**Telaio:** ferro piatto 15x60 mm zincato.  
**Trattamento a polvere:** Colori RAL a scelta. **Seduta e schienale:** legno duro non trattato o trattato. **Fissaggio:** in calcestruzzo, su pavimento solido o per collocamento libero.

**Ossature:** Fer plat 15x60 mm, galvanisé.  
**Revêtement poudre polyester:** Coloris RAL au choix. **Assise et dossier:** Lattes en bois exotique sans traitement ou avec traitement. **Scellement:** Dans le sol, en surface ou autostable.

## lineaseduta

mod. 377



Peso | Gewicht | Poids | Weight: 92 kg

**Gestell:** Flacheisen 15x60 mm, feuerverzinkt. **Pulverbeschichtung:** RAL-Farben nach Wahl. **Sitzauflage und Rückenlehne:** Hartholzbohlen unbehandelt oder behandelt. **Befestigung:** zum Einbetonieren, zum Aufschrauben oder zum freien Aufstellen.

**Frame:** flat bar 15x60 mm, galvanized. **Powder coating:** RAL colour to choose. **Seating and Back-rest:** hard wooden slats untreated or treated. **Fixation:** fixed in the ground, surface mounting, free-standing.

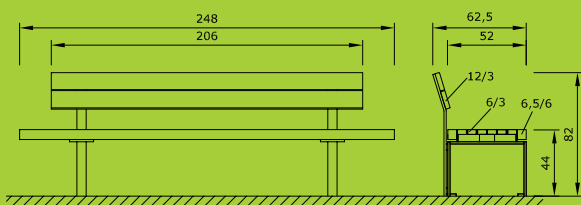

mod. 375

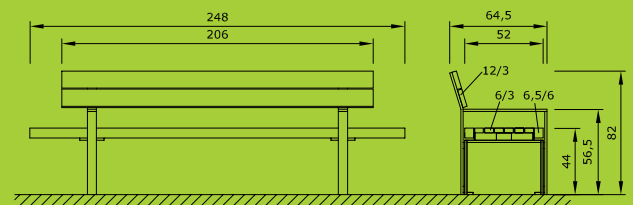

mod. 377

descrizione tecnica e disegni dwg | technische Beschreibung und dwg Zeichnungen | technical description and dwg drawings | description technique et dessins dwg: [www.euroform-w.com](http://www.euroform-w.com)





RATHAU  
KULTUR

US  
RHAUS



14



MUNICIPIO



## lineapanca

mod. 370, 372



Peso | Gewicht | Poids | Weight: 63 kg | 79 kg

## lineasedia

mod. 374, 376



Peso | Gewicht | Poids | Weight: 50 kg | 68 kg

## linea

mod. 381



Peso | Gewicht | Poids | Weight: 570 kg

**Telaio:** ferro piatto 15x60 mm zincato. **Trattamento a polvere:** Colori RAL a scelta. **Seduta e schienale:** legno duro non trattato o trattato. **Fissaggio:** in calcestruzzo, su pavimento solido o per collocamento libero.

**Ossature:** fer plat 15x60 mm, galvanisé. **Revêtement poudre polyester:** Coloris RAL au choix. **Assise et dossier:** Lattes en bois exotique sans traitement ou avec traitement de surface. **Scellement:** Dans le sol, en surface ou auto-stable.

## linea

mod. 382



Peso | Gewicht | Poids | Weight: 180 kg

**Gestell:** Flacheisen 15x60 mm, verzinkt. **Sitzaufgabe und Rückenlehne:** Hartholzbohlen unbehandelt oder behandelt. **Pulverbeschichtung:** RAL-Farben nach Wahl. **Befestigung:** zum Einbetonieren, zum Aufschrauben oder zum freien Aufstellen.

**Frame:** flat bar 15x60 mm, galvanized. **Powder coating:** RAL colour to choose. **Seating and Back-rest:** hard wooden slats untreated or treated. **Fixation:** fixed in the ground, surface mounting, free-standing.

# lineaflex

mod. 379



Peso | Gewicht | Poids | Weight: 92 kg

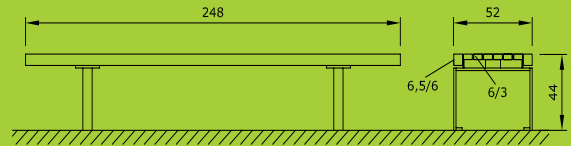

mod. 370

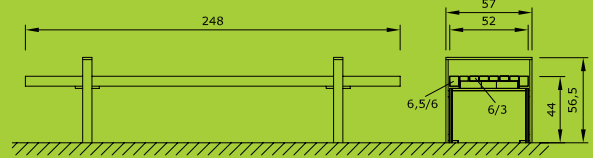

mod. 372

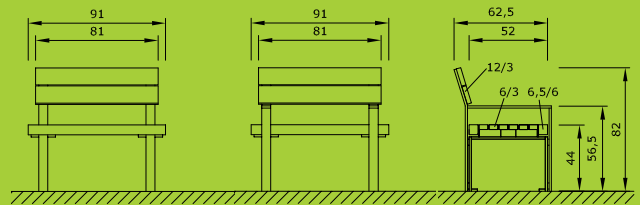

mod. 374, 376

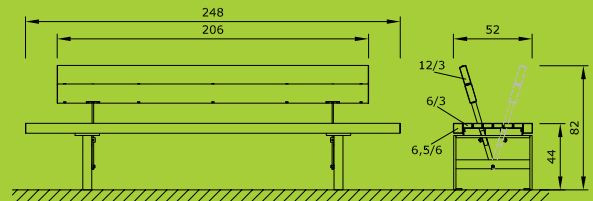

mod. 379

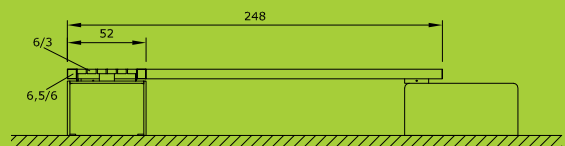

mod. 381

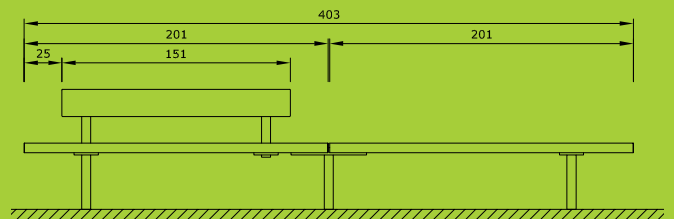

mod. 382

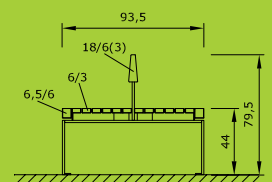

descrizione tecnica e disegni dwg  
 technische Beschreibung und dwg Zeichnungen  
 technical description and dwg drawings  
 description technique et dessins dwg:  
[www.euroform-w.com](http://www.euroform-w.com)





Den Haag, Brijders, Netherlands

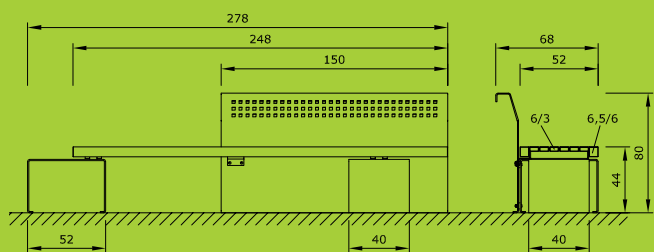

mod. 385

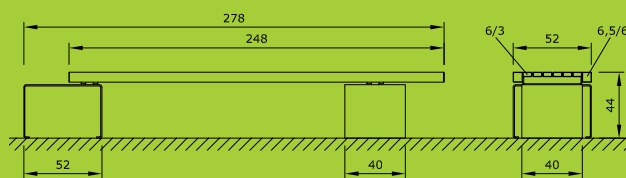

mod. 387

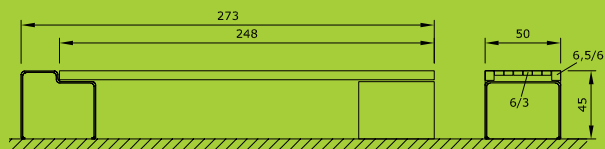

mod. 1310

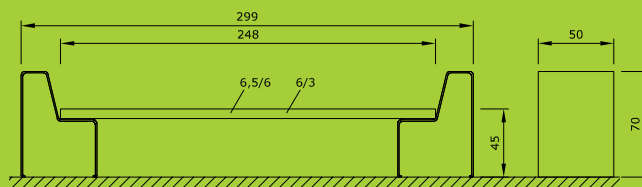

mod. 1315

descrizione tecnica e disegni dwg | technische Beschreibung und dwg Zeichnungen | technical description and dwg drawings | description technique et dessins dwg: [www.euroform-w.com](http://www.euroform-w.com)





## linea

mod. 385



Peso | Gewicht | Poids | Weight: 175 kg

## linea

mod. 387



Peso | Gewicht | Poids | Weight: 85 kg

## linea

mod. 1310



Peso | Gewicht | Poids | Weight: 120 kg

**Telaio:** lamiera d'acciaio spess. 6 mm zincato. **Trattamento a polvere:** Colori RAL a scelta. **Seduta e schienale:** legno duro non trattato o trattato. **Fissaggio:** in calcestruzzo, su pavimento solido o per collocamento libero.

**Ossature:** acier 6 mm galvanisé. **Revêtement poudre polyester:** Coloris RAL au choix. **Assise et dossier:** Lattes en bois exotique sans traitement ou avec traitement de surface. **Scellement:** Dans le sol, en surface ou autostable.

## linea

mod. 1315



Peso | Gewicht | Poids | Weight: 163 kg

**Gestell:** Stahlblech 6 mm verzinkt. **Sitzaufgabe und Rückenlehne:** Hartholzbohlen unbehandelt oder behandelt. **Pulverbeschichtung:** RAL-Farben nach Wahl. **Befestigung:** zum Einbetonieren, zum Aufschrauben oder zum freien Aufstellen.

**Frame:** 6 mm steel sheet galvanized. **Powder coating:** RAL colour to choose. **Seating and Back-rest:** hard wooden slats untreated or treated. **Fixation:** fixed in the ground, surface mounting, free-standing.

## linea

mod. 1310/1325



Peso | Gewicht | Poids | Weight: 285 kg

## linea

mod. 395



Peso | Gewicht | Poids | Weight: 67 kg

## lineaonda

mod. 398



Peso | Gewicht | Poids | Weight: 102 kg

**Telaio (mod. 1310/1325):** lamiera d'acciaio spess. 6 mm zincato. **Telaio (mod. 395, 398):** ferro piatto 15x60 mm zincato.  
**Trattamento a polvere:** Colori RAL a scelta. **Seduta e schienale:** legno duro non trattato o trattato. **Fissaggio:** in calcestruzzo, su pavimento solido o per collocamento libero.

**Ossature (mod. 1310/1325):** acier 6 mm galvanisé.  
**Ossature (mod. 395, 398):** Fer plat 15x60 mm, galvanisé.  
**Revêtement poudre polyester:** Coloris RAL au choix. **Assise et dossier:** Lattes en bois exotique sans traitement ou avec traitement de surface. **Scellement:** Dans le sol, en surface ou autostable.

**Gestell (mod. 1310/1325):** Stahlblech 6 mm verzinkt.  
**Gestell (mod. 395, 398):** Flacheisen 15x60 mm, verzinkt.  
**Pulverbeschichtung:** RAL-Farben nach Wahl. **Sitzauflage und Rückenlehne:** Hartholzbohlen unbehandelt oder behandelt. **Befestigung:** zum Einbetonieren, zum Aufschrauben oder zum freien Aufstellen.

**Frame (mod. 1310/1325):** 6 mm steel sheet galvanized.  
**Frame (mod. 395, 398):** flat bar 15x60 mm, galvanized.  
**Powder coating:** RAL colour to choose. **Seating and Backrest:** hard wooden slats untreated or treated. **Fixation:** fixed in the ground, surface mounting, free-standing.

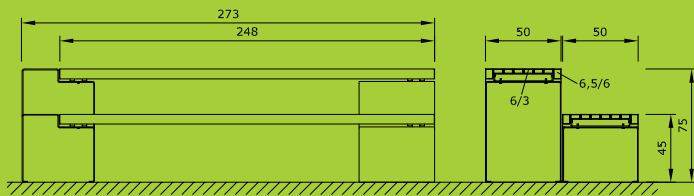

mod. 1310/1325

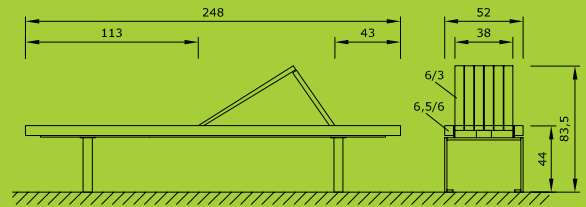

mod. 395

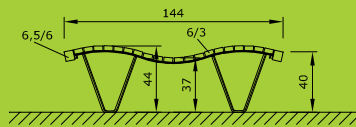

mod. 398

descrizione tecnica e disegni dwg | technische Beschreibung und dwg Zeichnungen | technical description and dwg drawings | description technique et dessins dwg: [www.euroform-w.com](http://www.euroform-w.com)



Scuola, San Cassiano, Alta Badia, Bolzano, Italy

## lineaseduta light

mod. 375L



Peso | Gewicht | Poids | Weight: 70 kg

## lineaseduta light

mod. 377L



Peso | Gewicht | Poids | Weight: 76 kg

## lineapanca light

mod. 370L



Peso | Gewicht | Poids | Weight: 51 kg

**Telaio:** ferro piatto 10x60 mm zincato. **Trattamento a polvere:** Colori RAL a scelta. **Seduta e schienale:** legno duro non trattato o trattato. **Fissaggio:** in calcestruzzo, su pavimento solido o per collocamento libero.

**Ossature:** Fer plat 10x60 mm, galvanisé. **Revêtement poudre polyester:** Coloris RAL au choix. **Assise et dossier:** Lattes en bois exotique sans traitement ou avec traitement de surface. **Scellement:** Dans le sol, en surface ou auto-stable.

## lineapanca light

mod. 372L



Peso | Gewicht | Poids | Weight: 59 kg

**Gestell:** Flacheisen 10x60 mm, verzinkt. **Pulverbeschichtung:** RAL-Farben nach Wahl. **Sitzauflage und Rückenlehne:** Hartholzbohlen unbehandelt oder behandelt. **Befestigung:** zum Einbetonieren, zum Aufschrauben oder zum freien Aufstellen.

**Frame:** flat bar 10x60 mm, galvanized. **Powder coating:** RAL colour to choose. **Seating and Back-rest:** hard wooden slats untreated or treated. **Fixation:** fixed in the ground, surface mounting, free-standing.

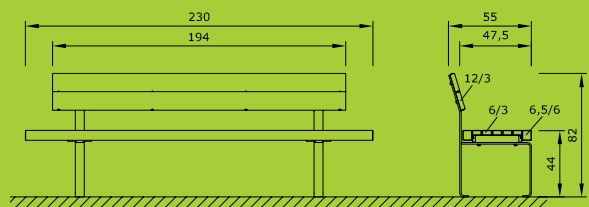

mod. 375L

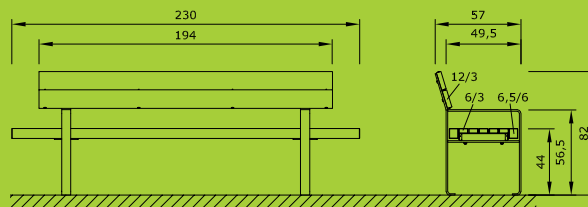

mod. 377L

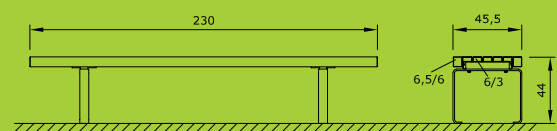

mod. 370L

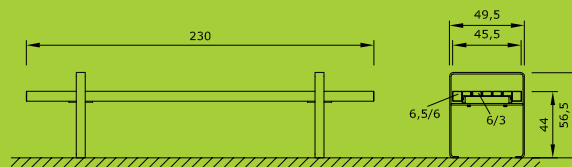

mod. 372L

descrizione tecnica e disegni dwg | technische Beschreibung und dwg Zeichnungen | technical description and dwg drawings | description technique et dessins dwg: [www.euroform-w.com](http://www.euroform-w.com)



Campo Tures, Bolzano, Italy



Dax, France

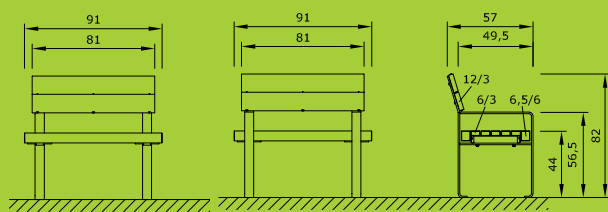

mod. 374L, 376L

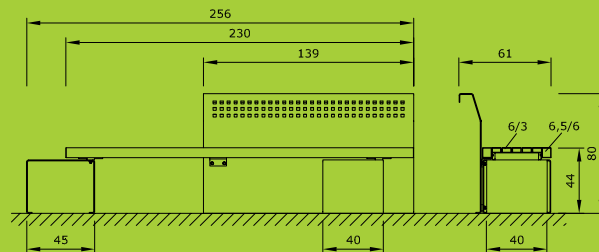

mod. 385L

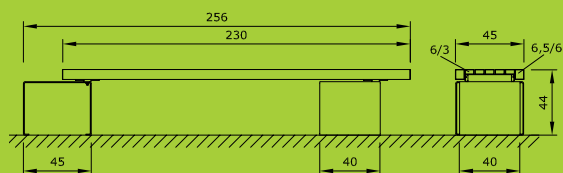

mod. 387L

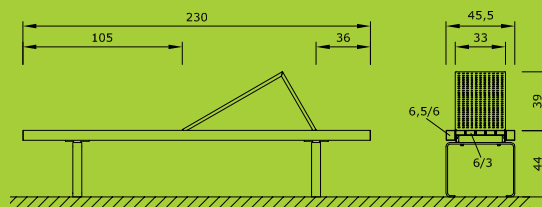

mod. 395L

descrizione tecnica e disegni dwg | technische Beschreibung und dwg Zeichnungen | technical description and dwg drawings | description technique et dessins dwg: [www.euroform-w.com](http://www.euroform-w.com)



## lineasedia light

mod. 374L, 376L



Peso | Gewicht | Poids | Weight: 40 kg | 46 kg

## linea light

mod. 385L



Peso | Gewicht | Poids | Weight: 137 kg

## linea light

mod. 387L



Peso | Gewicht | Poids | Weight: 70 kg

**Telaio (mod. 374L, 376L, 395L):** ferro piatto 10x60 mm zincato. **Telaio (mod. 385L, 387L):** lamiera d'acciaio 4 mm, zincato. **Trattamento a polvere:** Colori RAL a scelta. **Sedute e schienale:** legno duro non trattato o trattato. **Schienale (mod. 385L):** lamiera d'acciaio forata spess. 6 mm, fori 20x20 mm. **Schienale (mod. 395L):** lamiera d'acciaio 2 mm - fori 10x10 mm, zincato. **Fissaggio:** in calcestruzzo, su pavimento solido o per collocamento libero.

**Ossature (mod. 374L, 376L, 395L):** Fer plat 10x60 mm, galvanisé à chaud. **Ossature (mod. 385L, 387L):** Tôle perforée 4 mm, galvanisé. **Revêtement poudre polyester:** Coloris RAL au choix. **Assise et dossier:** Lattes en bois exotique sans traitement ou avec traitement de surface. **Dossier (mod. 385L):** Tôle perforée 6 mm, perforations 20x20 mm, galvanisé. **Dossier (mod. 395L):** Tôle perforée 6 mm, perforations 10x10 mm, galvanisé. **Scellement:** Dans le sol, en surface ou autostable.

## linea light

mod. 395L



Peso | Gewicht | Poids | Weight: 57 kg

**Gestell (mod. 374L, 376L, 395L):** Flacheisen 10x60 mm, feuerverzinkt. **Gestell (mod. 385L, 387L):** Lochblech 4 mm, verzinkt. **Pulverbeschichtung:** RAL-Farben nach Wahl. **Sitzauflage und Rückenlehne:** Hartholzbohlen unbehandelt oder behandelt. **Rückenlehne (mod. 385L):** Lochblech 6 mm, Quadratlöcher 20x20 mm, verzinkt. **Rückenlehne (mod. 395L):** Lochblech 6 mm, Quadratlöcher 10x10 mm, verzinkt. **Befestigung:** zum Einbetonieren, zum Aufschrauben oder zum freien Aufstellen.

**Frame (mod. 374L, 376L, 395L):** flat bar 10x60 mm, hot-dip galvanized. **Frame (mod. 385L, 387L):** perforated metal 4 mm galvanized. **Powder coating:** RAL colour to choose. **Seating and Back-rest:** hard wooden slats untreated or treated. **Back-rest (mod. 385L):** perforated metal 6 mm, holes 20x20 mm, galvanized. **Back-rest (mod. 395L):** perforated metal 6 mm, holes 10x10 mm, galvanized. **Fixation:** fixed in the ground, surface mounting, free-standing.

## allone

mod. 1010

also for  
senior



Peso | Gewicht | Poids | Weight: 85 kg

**Telaio:** lamiera d'acciaio zincata spess. 6 mm. Rinforzo orizzontale tubo mobilio da Ø42 mm. **Trattamento a polvere:** Colori RAL a scelta. **Seduta e schienale:** legno duro non trattato o trattato. **Fissaggio:** in calcestruzzo, su pavimento solido o per collocamento libero.

**Ossature:** tôle d'acier 6 mm galvanisé. Barre transversale en tube rond Ø42 mm. **Revêtement poudre polyester:** Coloris RAL au choix. **Assise et dossier:** Lattes en bois exotique sans traitement ou avec traitement de surface. **Scellement:** Dans le sol, en surface ou autostable.

## allbench

mod. 1005



Peso | Gewicht | Poids | Weight: 70 kg

**Gestell:** Stahlblech 6 mm, verzinkt. Querverstrebung aus Rundrohr Ø42 mm. **Pulverbeschichtung:** RAL-Farben nach Wahl. **Sitzauflage und Rückenlehne:** Hartholzbohlen unbehandelt oder behandelt. **Befestigung:** zum Einbetonieren, zum Aufschrauben oder zum freien Aufstellen.

**Frame:** galvanized 6 mm sheet steel. Horizontal reinforcement with round section pipe Ø42 mm. **Powder coating:** RAL colour to choose. **Seating and back-rest:** hard wooden slats untreated or treated. **Fixation:** fixed in the ground, surface mounting, free-standing.

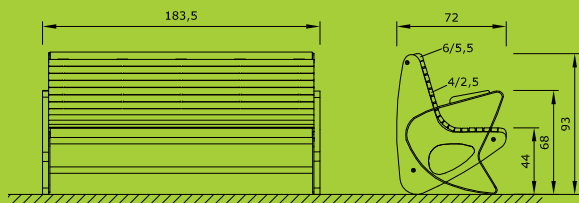

mod. 1010

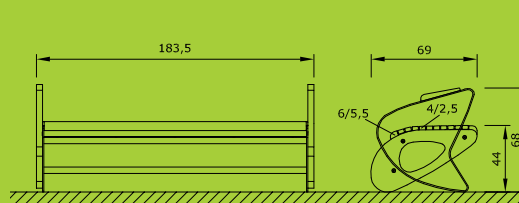

mod. 1005

descrizione tecnica e disegni dwg | technische Beschreibung und dwg Zeichnungen | technical description and dwg drawings | description technique et dessins dwg: [www.euroform-w.com](http://www.euroform-w.com)





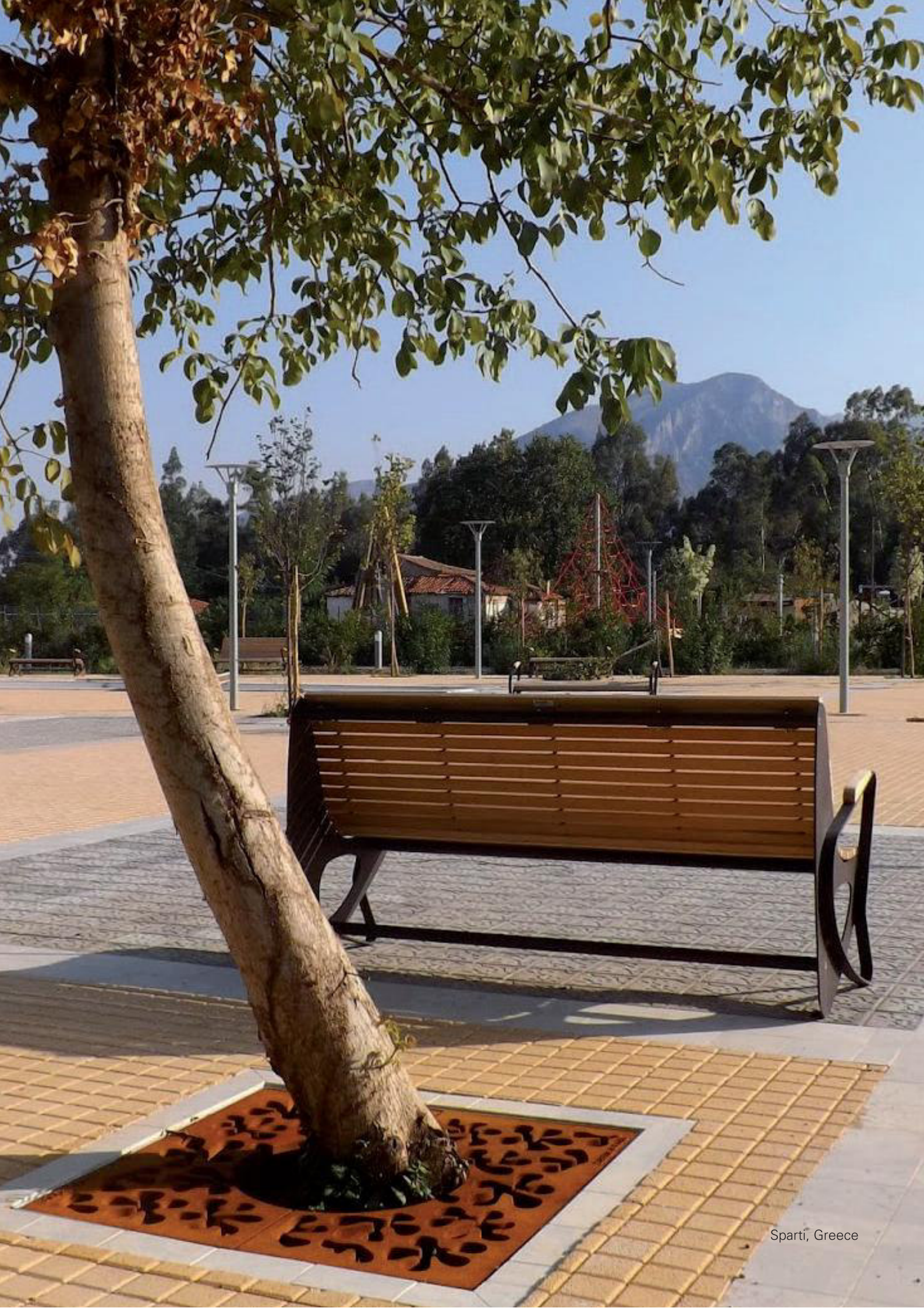

Sparta, Greece

## alldouble

mod. 1010, 1005



Peso | Gewicht | Poids | Weight: 155 kg

## allrelax

mod. 1015

also for senior



Peso | Gewicht | Poids | Weight: 30 kg

## allmore

mod. 1016, 1017, 1018

also for senior



Peso | Gewicht | Poids | Weight: 19 kg - mod. 1016

Peso | Gewicht | Poids | Weight: 3 kg - mod. 1017

Peso | Gewicht | Poids | Weight: 2 kg - mod. 1018

**Telaio:** lamiera d'acciaio zincata spess. 6 mm. Rinforzo orizzontale tubo mobilio da Ø42 mm. **Trattamento a polvere:** Colori RAL a scelta. **Seduta e schienale:** legno duro non trattato o trattato. **Fissaggio:** in calcestruzzo, su pavimento solido o per collocamento libero.

**Ossature:** tôle d'acier 6 mm galvanisé. Barre transversale en tube rond Ø42 mm. **Revêtement poudre polyester:** Coloris RAL au choix. **Assise et dossier:** Lattes en bois exotique sans traitement ou avec traitement de surface. **Scellement:** Dans le sol, en surface ou autostable.

## albed

mod. 1025



Peso | Gewicht | Poids | Weight: 89 kg

**Gestell:** Stahlblech 6 mm, verzinkt. Querverstrebung aus Rundrohr Ø42 mm. **Pulverbeschichtung:** RAL-Farben nach Wahl. **Sitzaufgabe und Rückenlehne:** Hartholzbohlen unbehandelt oder behandelt. **Befestigung:** zum Einbetonieren, zum Aufschrauben oder zum freien Aufstellen.

**Frame:** galvanized 6 mm sheet steel. Horizontal reinforcement with round section pipe, Ø42 mm. **Powder coating:** RAL colour to choose. **Seating and back-rest:** hard wooden slats untreated or treated. **Fixation:** fixed in the ground, surface mounting, free-standing.

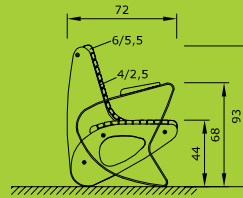
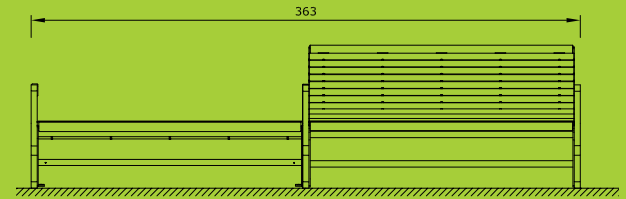

mod. 1010, 1005

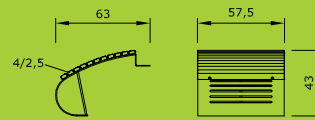

mod. 1015

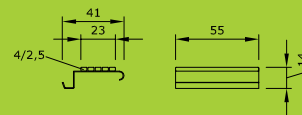

mod. 1016

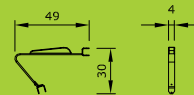

mod. 1017

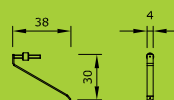

mod. 1018

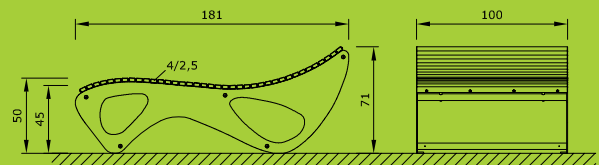

mod. 1025

descrizione tecnica e disegni dwg  
 technische Beschreibung und dwg Zeichnungen  
 technical description and dwg drawings  
 description technique et dessins dwg:  
[www.euroform-w.com](http://www.euroform-w.com)



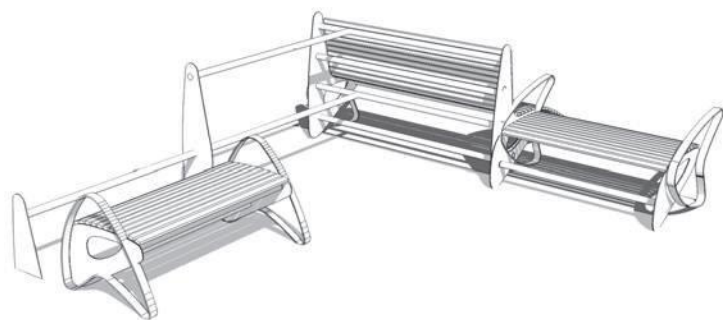

**Youtube Video**

Esercizi | Übungen  
Exercises | Exercices

Esercizi di allungamento e mobilità  
Dehn-, Streck- und Mobilitätsübungen  
Exercices d'extension – d'étirement et de mobilité  
Stretching and mobility exercises

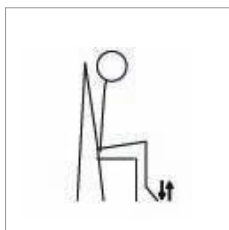
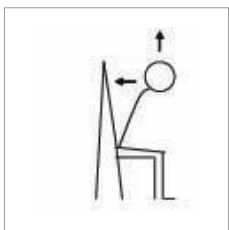
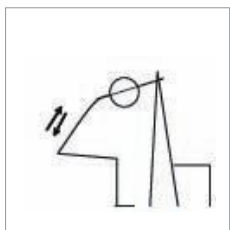
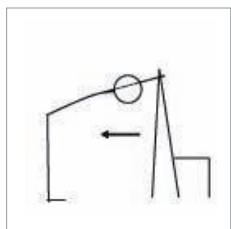
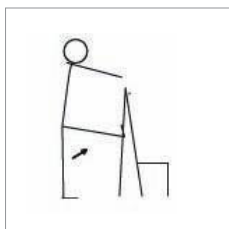

Esercizi di rinforzo  
Stärkungsübung  
Exercices de renforcement  
Strengthening exercises

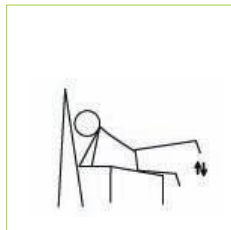
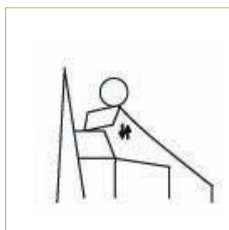
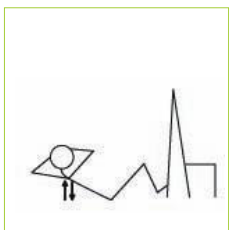
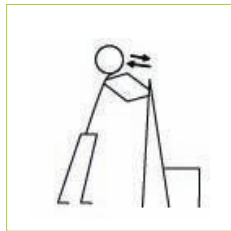
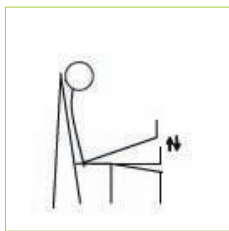



Campo Tures, Italy



House for elderly, Bolzano, Italy

## zetaseduta

mod. 1405



Peso | Gewicht | Poids | Weight: 55 kg

## zetaseduta

mod. 1407



Peso | Gewicht | Poids | Weight: 66 kg

## zetapanca

mod. 1400



Peso | Gewicht | Poids | Weight: 36 kg

**Telaio:** ferro piatto 8x80 mm e 10x80 mm, zincato. **Trattamento a polvere:** Colori RAL a scelta. **Seduta e schienale:** legno duro non trattato o trattato. **Fissaggio:** in calcestruzzo, su pavimento solido o per collocamento libero.

**Ossature:** Fer plat 8x80 mm et 10x80 mm, galvanisé. **Revêtement poudre polyester:** Coloris RAL au choix. **Assise et dossier:** Lattes en bois exotique sans traitement ou avec traitement de surface. **Scellement:** Dans le sol, en surface ou autostable.

## zetapanca

mod. 1402



Peso | Gewicht | Poids | Weight: 51 kg

**Gestell:** Flacheisen 8x80 mm und 10x80 mm, verzinkt. **Pulverbeschichtung:** RAL-Farben nach Wahl. **Sitzaufgabe und Rückenlehne:** Hartholzbohlen unbehandelt oder behandelt. **Befestigung:** zum Einbetonieren, zum Aufschrauben oder zum freien Aufstellen.

**Frame:** flat bar 8x80 mm and 10x80 mm, galvanized. **Powder coating:** RAL colour to choose. **Seating and Back-rest:** hard wooden slats untreated or treated. **Fixation:** fixed in the ground, surface mounting, free-standing.

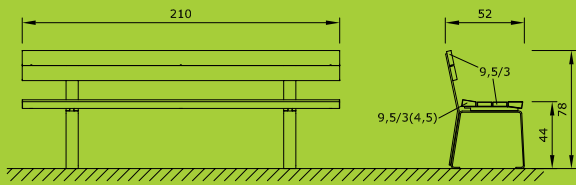

mod. 1405

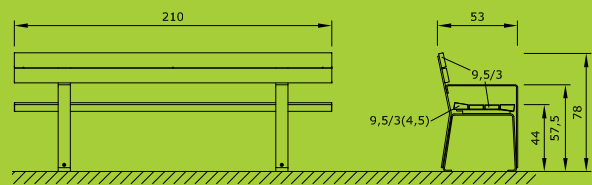

mod. 1407

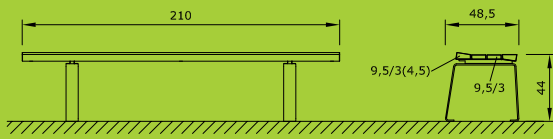

mod. 1400

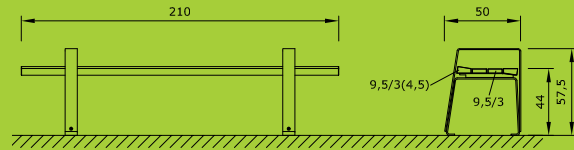

mod. 1402

descrizione tecnica e disegni dwg | technische Beschreibung und dwg Zeichnungen | technical description and dwg drawings | description technique et dessins dwg: [www.euroform-w.com](http://www.euroform-w.com)



Park Orzali, Monsummano Terme, Pistoia, Italy

# victor

mod. 1500, 1505



Peso | Gewicht | Poids | Weight: 31 kg | 52 kg

**Telaio:** lamiera d'acciaio 10 mm, zincato. **Trattamento a polvere:** Colori RAL a scelta. **Seduta e schienale:** legno duro non trattato o trattato. **Fissaggio:** in calcestruzzo, su pavimento solido o per collocamento libero.

**Ossature:** tôle d'acier 10 mm, galvanisé. **Revêtement poudre polyester:** Coloris RAL au choix. **Assise et dossier:** Lattes en bois exotique sans traitement ou avec traitement de surface. **Scellement:** Dans le sol, en surface ou auto-stable.

**Gestell:** Stahlblech 10 mm, verzinkt. **Pulverbeschichtung:** RAL-Farben nach Wahl. **Sitzauflage und Rückenlehne:** Hartholzbohlen unbehandelt oder behandelt. **Befestigung:** zum Einbetonieren, zum Aufschrauben oder zum freien Aufstellen.

**Frame:** 10 mm sheet steel, galvanized. **Powder coating:** RAL colour to choose. **Seating and Back-rest:** hard wooden slats untreated or treated. **Fixation:** fixed in the ground, surface mounting, free-standing.

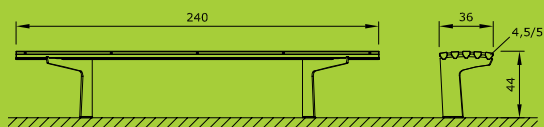

mod. 1500

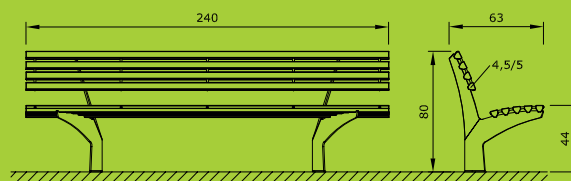

mod. 1505

descrizione tecnica e disegni dwg | technische Beschreibung und dwg Zeichnungen | technical description and dwg drawings | description technique et dessins dwg: [www.euroform-w.com](http://www.euroform-w.com)





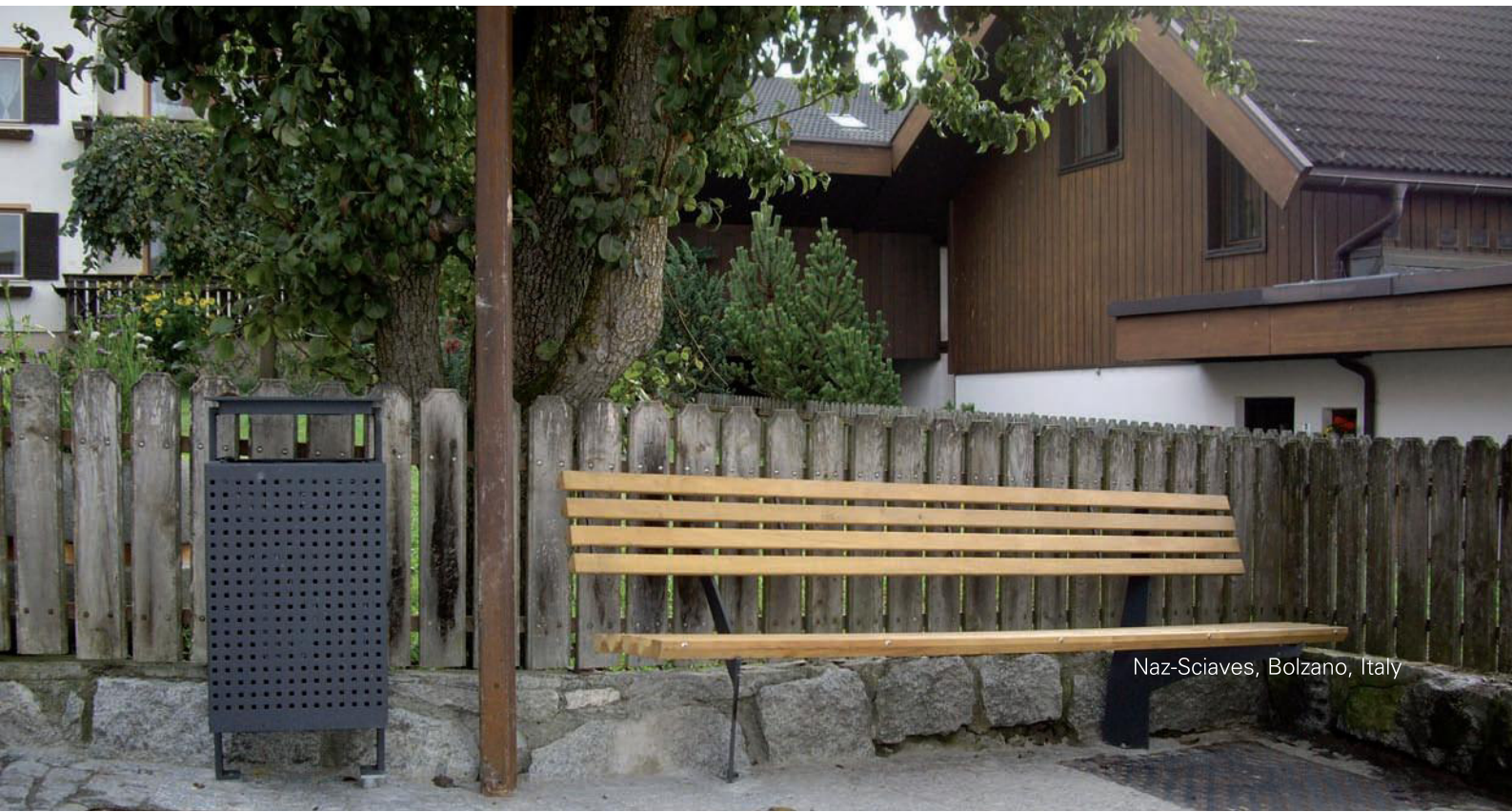

Naz-Sciaves, Bolzano, Italy

## link

mod. 1600



Peso | Gewicht | Poids | Weight: 28 kg

**Telaio:** tubo rettangolare 150x40 mm zincato a fuoco.  
**Trattamento a polvere:** Colori RAL a scelta. **Seduta:** legno duro non trattato o trattato. **Fissaggio:** in calcestruzzo, su pavimento solido o per collocamento libero.

**Ossature:** tube rectangulaire 150x40 mm, galvanisé à chaud  
**Revêtement poudre polyester:** Coloris RAL au choix.  
**Assise:** Lattes en bois exotique sans traitement ou avec traitement de surface. **Scellement:** Dans le sol, en surface ou autostable.

## movelink

mod. 1610



Peso | Gewicht | Poids | Weight: 48 kg

**Gestell:** Rechteckrohr 150x40 mm feuerverzinkt. **Pulverbeschichtung:** RAL-Farben nach Wahl. **Sitzaufgabe:** Hartholzbohlen unbehandelt oder behandelt. **Befestigung:** zum Einbetonieren, zum Aufschrauben oder zum freien Aufstellen.

**Frame:** rectangular tube 150x40 mm hot-dip galvanized.  
**Powder coating:** RAL colour to choose. **Seating:** hard wooden slats untreated or treated. **Fixation:** fixed in the ground, surface mounting, free-standing.

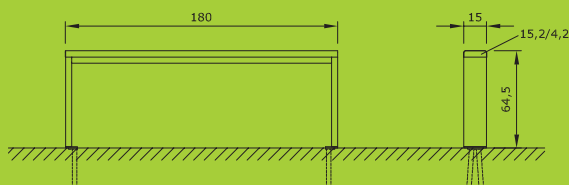

mod. 1600

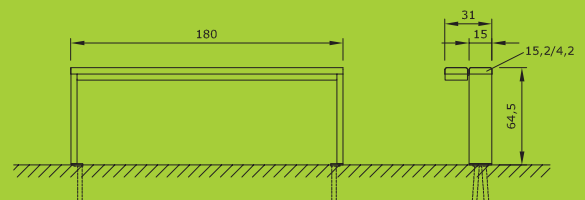

mod. 1610

descrizione tecnica e disegni dwg | technische Beschreibung und dwg Zeichnungen | technical description and dwg drawings | description technique et dessins dwg: [www.euroform-w.com](http://www.euroform-w.com)





Cagliari, Italy



# comfort

mod. 345, 346, 347

also for  
senior



Peso | Gewicht | Poids | Weight: 31 kg | 43 kg | 57 kg

**Telaio:** ferro piatto 10x50 mm, zincato. **Trattamento a polvere:** Colori RAL a scelta. **Seduta e schienale:** legno duro non trattato o trattato. **Fissaggio:** in calcestruzzo, su pavimento solido o per collocamento libero.

**Ossature:** Fer plat 10x50 mm, galvanisé. **Revêtement poudre polyester:** Coloris RAL au choix. **Assise et dossier:** Lattes en bois exotique sans traitement ou avec traitement de surface. **Scellement:** Dans le sol, en surface ou auto-stable.

**Gestell:** Flacheisen 10x50 mm, verzinkt. **Pulverbeschichtung:** RAL-Farben nach Wahl. **Sitzauflage und Rückenlehne:** Hartholzbohlen unbehandelt oder behandelt. **Befestigung:** zum Einbetonieren, zum Aufschrauben oder zum freien Aufstellen.

**Frame:** flat steel 10x50 mm, galvanized. **Powder coating:** RAL colour to choose. **Seating and Back-rest:** hard wooden slats untreated or treated. **Fixation:** fixed in the ground, surface mounting, free-standing.



Campo Tures, Bolzano, Italy

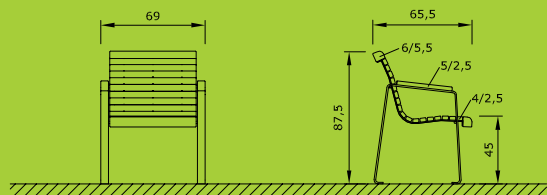

mod. 345

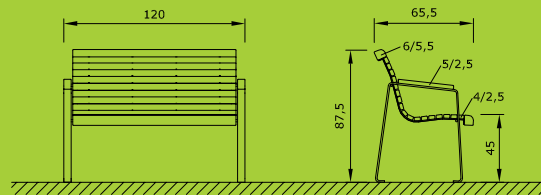

mod. 346

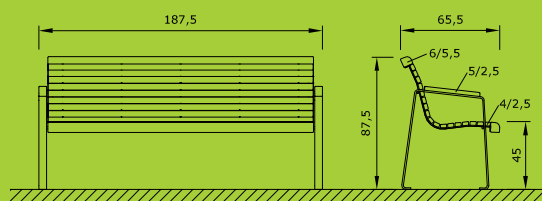

mod. 347



descrizione tecnica e disegni dwg | technische Beschreibung und dwg Zeichnungen | technical description and dwg drawings | description technique et dessins dwg: [www.euroform-w.com](http://www.euroform-w.com)



## contour

mod. 319S, 319FS

also for  
senior



Peso | Gewicht | Poids | Weight: 22 kg

## contour

mod. 320S, 320FS

also for  
senior



Peso | Gewicht | Poids | Weight: 30 kg

## contour

mod. 321S, 321FS

also for  
senior



Peso | Gewicht | Poids | Weight: 49 kg

## contour

mod. 322, 322F



Peso | Gewicht | Poids | Weight: 17 kg

**Telaio:** tubo d'acciaio Ø30 mm zincato a fuoco. **Trattamento a polvere:** Colori RAL a scelta. **Seduta e schienale:** legno duro non trattato o trattato. **Fissaggio:** in calcestruzzo, su pavimento solido o per collocamento libero.

**Ossature:** tube d'acier Ø30 mm galvanisé à chaud. **Revêtement poudre polyester:** Coloris RAL au choix. **Assise et dossier:** Lattes en bois exotique sans traitement ou avec traitement de surface. **Scellement:** Dans le sol, en surface ou autostable.

**Gestell:** Stahlrohr Ø30 mm feuerverzinkt. **Pulverbeschichtung:** RAL-Farben nach Wahl. **Sitzauflage und Rückenlehne:** Hartholzbohlen unbehandelt oder behandelt. **Befestigung:** zum Einbetonieren, zum Aufschrauben oder zum freien Aufstellen.

**Frame:** tubular steel Ø30 mm, hot-dip galvanized. **Powder coating:** RAL colour to choose. **Seating and Back-rest:** hard wooden slats untreated or treated. **Fixation:** fixed in the ground, surface mounting, free-standing.

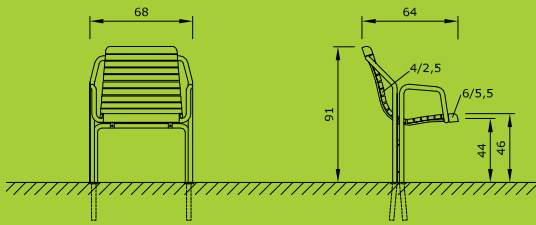

mod. 319S, mod. 319FS

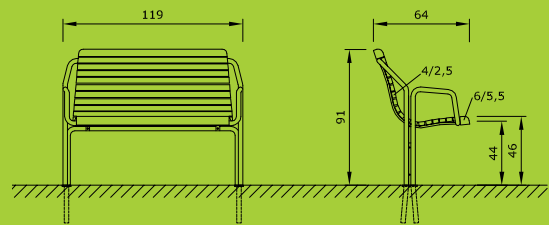

mod. 320S, mod. 320FS

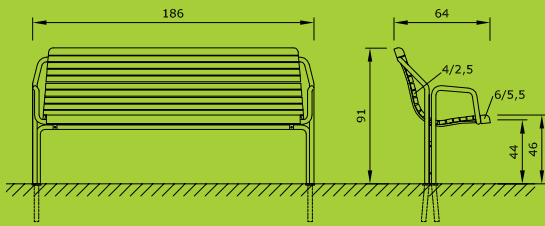

mod. 321S, mod. 321FS

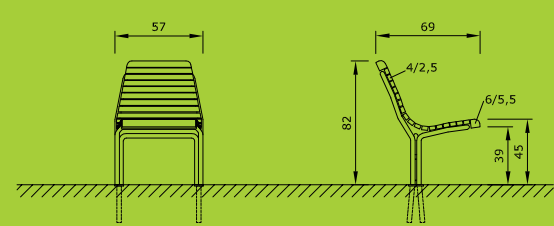

mod. 322, mod. 322F

descrizione tecnica e disegni dwg | technische Beschreibung und dwg Zeichnungen | technical description and dwg drawings | description technique et dessins dwg: [www.euroform-w.com](http://www.euroform-w.com)



House for the elderly, Gleno, Bergamo, Italy



Chienes, Italy

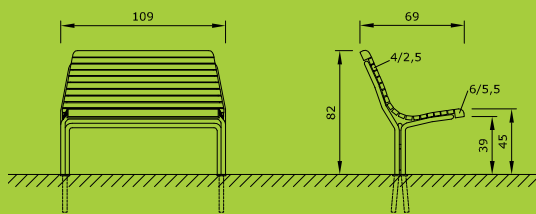

mod. 323



mod. 323F

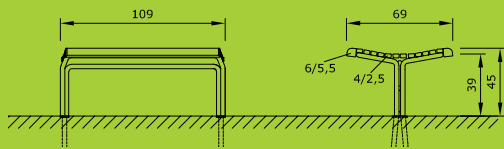

mod. 324



mod. 324F

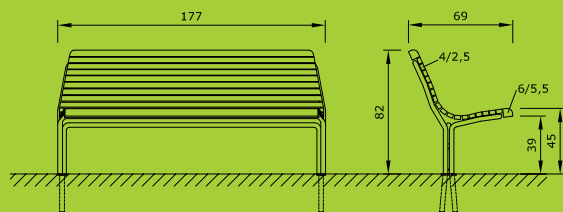

mod. 325

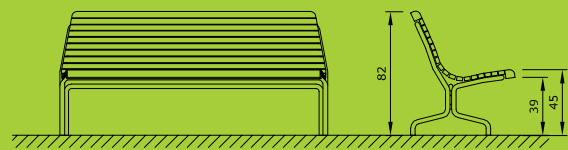

mod. 325F

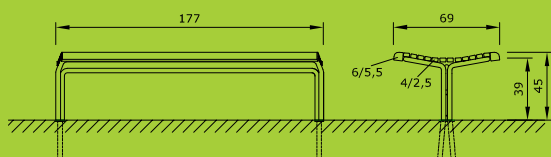

mod. 326



mod. 326F

descrizione tecnica e disegni dwg | technische Beschreibung und dwg Zeichnungen | technical description and dwg drawings | description technique et dessins dwg: [www.euroform-w.com](http://www.euroform-w.com)





## contour

mod. 323, 323F



Peso | Gewicht | Poids | Weight: 27 kg

## contour

mod. 324, 324F



Peso | Gewicht | Poids | Weight: 25 kg

## contour

mod. 325, 325F



Peso | Gewicht | Poids | Weight: 41 kg

**Telaio:** tubo d'acciaio Ø30 mm zincato a fuoco. **Trattamento a polvere:** Colori RAL a scelta. **Seduta e schienale:** legno duro non trattato o trattato. **Fissaggio:** in calcestruzzo, su pavimento solido o per collocamento libero.

**Ossature:** tube d'acier Ø30 mm galvanisé à chaud. **Revêtement poudre polyester:** Coloris RAL au choix. **Assise et dossier:** Lattes en bois exotique sans traitement ou avec traitement de surface. **Scellement:** Dans le sol, en surface ou autostable.

## contour

mod. 326, 326F



Peso | Gewicht | Poids | Weight: 40 kg

**Gestell:** Stahlrohr Ø30 mm feuerverzinkt. **Pulverbeschichtung:** RAL-Farben nach Wahl. **Sitzauflage und Rückenlehne:** Hartholzbohlen unbehandelt oder behandelt. **Befestigung:** zum Einbetonieren, zum Aufschrauben oder zum freien Aufstellen.

**Frame:** tubular steel Ø30 mm, hot-dip galvanized. **Powder coating:** RAL colour to choose. **Seating and Back-rest:** hard wooden slats untreated or treated. **Fixation:** fixed in the ground, surface mounting, free-standing.





Corso de Nicolò, Torino, Italy

## contour

mod. 327



Peso | Gewicht | Poids | Weight: 16 kg

## contour

mod. 328



Peso | Gewicht | Poids | Weight: 30,5 kg

## contour

mod. 329



Peso | Gewicht | Poids | Weight: 18 kg

## contour

mod. 330



Peso | Gewicht | Poids | Weight: 27 kg

**Telaio:** tubo d'acciaio Ø30 mm zincato a fuoco. **Trattamento a polvere:** Colori RAL a scelta. **Seduta e schienale:** legno duro non trattato o trattato. **Fissaggio:** in calcestruzzo, su pavimento solido o per collocamento libero.

**Ossature:** tube d'acier Ø30 mm galvanisé à chaud. **Revêtement poudre polyester:** Coloris RAL au choix. **Assise et dossier:** Lattes en bois exotique sans traitement ou avec traitement de surface. **Scellement:** Dans le sol, en surface ou autostable.

**Gestell:** Stahlrohr Ø30 mm feuerverzinkt. **Pulverbeschichtung:** RAL-Farben nach Wahl. **Sitzauflage und Rückenlehne:** Hartholzbohlen unbehandelt oder behandelt. **Befestigung:** zum Einbetonieren, zum Aufschrauben oder zum freien Aufstellen.

**Frame:** tubular steel Ø30 mm, hot-dip galvanized. **Powder coating:** RAL colour to choose. **Seating and Back-rest:** hard wooden slats untreated or treated. **Fixation:** fixed in the ground, surface mounting, free-standing.

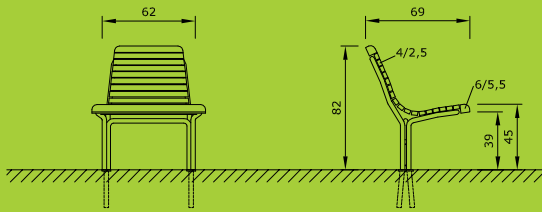

mod. 327

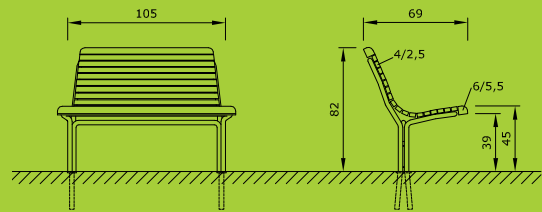

mod. 328

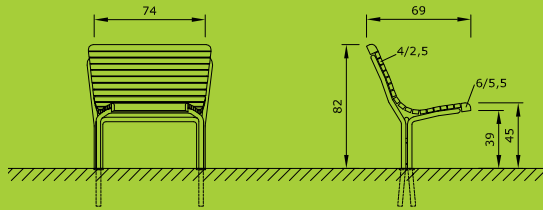

mod. 329

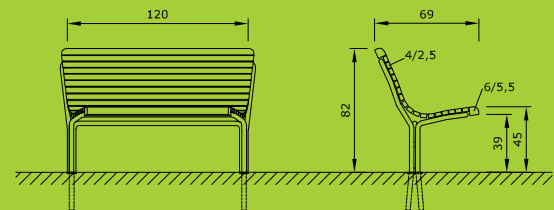

mod. 330

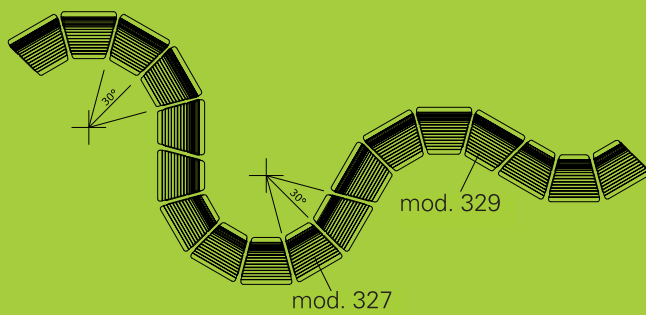

mod. 328

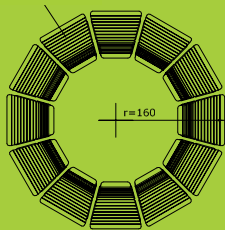

mod. 329

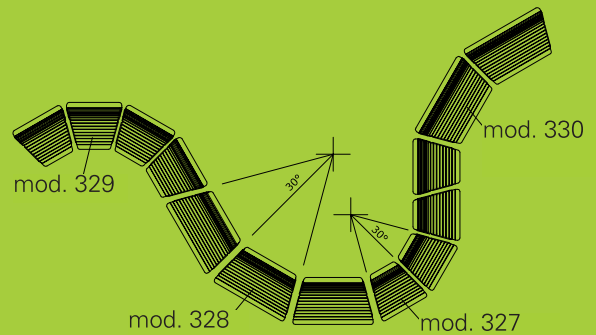
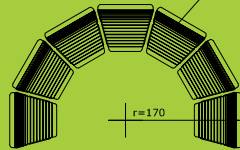

mod. 328

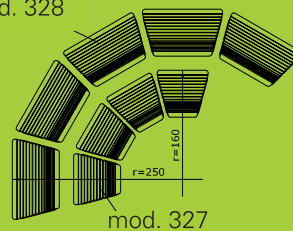

mod. 330

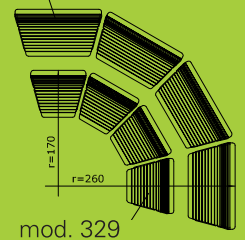

descrizione tecnica e disegni dwg | technische Beschreibung und dwg Zeichnungen | technical description and dwg drawings | description technique et dessins dwg: [www.euroform-w.com](http://www.euroform-w.com)



## contour

mod. 332W

---



Peso | Gewicht | Poids | Weight: 18 kg

## contour

mod. 334W

---



Peso | Gewicht | Poids | Weight: 26 kg

## contour

mod. 332M

---



Peso | Gewicht | Poids | Weight: 18 kg

**Telaio:** tubo d'acciaio Ø30 mm zincato a fuoco. **Trattamento a polvere:** Colori RAL a scelta. **Seduta e schienale:** legno duro non trattato o trattato. **Fissaggio:** su muro o contro parete.

**Ossature:** tube d'acier Ø30 mm galvanisé à chaud. **Revêtement poudre polyester:** Coloris RAL au choix. **Assise et dossier:** Lattes en bois exotique sans traitement ou avec traitement de surface. **Scellement:** sur muret ou fixation murale.

## contour

mod. 334M

---



Peso | Gewicht | Poids | Weight: 26 kg

**Gestell:** Stahlrohr Ø30 mm feuerverzinkt. **Pulverbeschichtung:** RAL-Farben nach Wahl. **Sitzauflage und Rückenlehne:** Hartholzbohlen unbehandelt oder behandelt. **Befestigung:** Mauer- oder Wandmontage.

**Frame:** tubular steel Ø30 mm, hot-dip galvanized. **Powder coating:** RAL colour to choose. **Seating and Back-rest:** hard wooden slats untreated or treated. **Fixation:** wall mounted or plinth mounted.

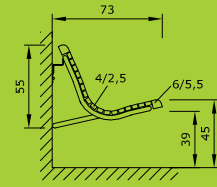
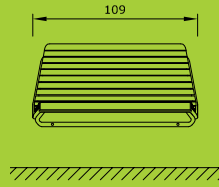
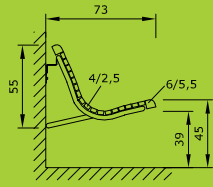
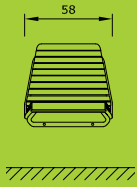

mod. 332W

mod. 334W

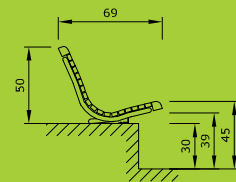
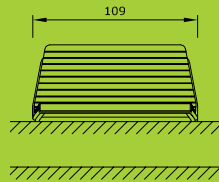
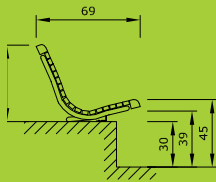

mod. 332M

mod. 334M

descrizione tecnica e disegni dwg | technische Beschreibung und dwg Zeichnungen | technical description and dwg drawings | description technique et dessins dwg: [www.euroform-w.com](http://www.euroform-w.com)



Weeze, Niederrhein, Germany







Pesaro Urbino, Italy

## contour

mod. 340



Peso | Gewicht | Poids | Weight: 48 kg

**Telaio:** tubo d'acciaio Ø30 mm zincato a fuoco. **Trattamento a polvere:** Colori RAL a scelta. **Seduta e schienale:** legno duro non trattato o trattato. **Fissaggio:** in calcestruzzo, su pavimento solido o per collocamento libero.

**Ossature:** tube d'acier Ø30 mm galvanisé à chaud. **Revêtement poudre polyester:** Coloris RAL au choix. **Assise et dossier:** Lattes en bois exotique sans traitement ou avec traitement de surface. **Scellement:** Dans le sol, en surface ou autostable.

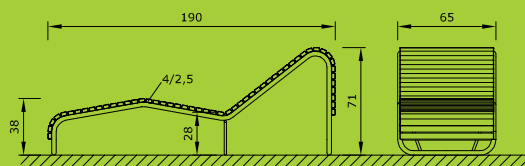

mod. 340

## contour

mod. 325/22



Peso | Gewicht | Poids | Weight: 72 kg

**Gestell:** Stahlrohr Ø30 mm feuerverzinkt. **Pulverbeschichtung:** RAL-Farben nach Wahl. **Sitzaufgabe und Rückenlehne:** Hartholzbohlen unbehandelt oder behandelt. **Befestigung:** zum Einbetonieren, zum Aufschrauben oder zum freien Aufstellen.

**Frame:** tubular steel Ø30 mm, hot-dip galvanized. **Powder coating:** RAL colour to choose. **Seating and Back-rest:** hard wooden slats untreated or treated. **Fixation:** fixed in the ground, surface mounting, free-standing.

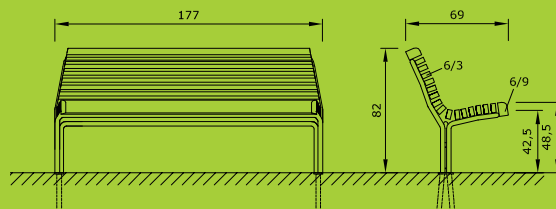

mod. 325/22

descrizione tecnica e disegni dwg | technische Beschreibung und dwg Zeichnungen | technical description and dwg drawings | description technique et dessins dwg: [www.euroform-w.com](http://www.euroform-w.com)





# ambiente

mod. 53, 54, 55



Peso | Gewicht | Poids | Weight: 30 kg | 40 kg | 52 kg

**Telaio:** tondino di ferro Ø12 mm zincato a fuoco. **Trattamento a polvere:** Colori RAL a scelta. **Seduta e schienale:** legno duro non trattato o trattato. **Fissaggio:** in calcestruzzo, su pavimento solido o per collocamento libero.

**Ossature:** fer plein Ø12 mm galvanisé à chaud. **Revêtement poudre polyester:** Coloris RAL au choix. **Assise et dossier:** Lattes en bois exotique sans traitement ou avec traitement de surface. **Scellement:** Dans le sol, en surface ou autostable.



**Gestell:** Rundeisen Ø12 mm feuerverzinkt. **Pulverbeschichtung:** RAL-Farben nach Wahl. **Sitzaufgabe und Rückenlehne:** Hartholzbohlen unbehandelt oder behandelt. **Befestigung:** zum Einbetonieren, zum Aufschrauben oder zum freien Aufstellen.

**Frame:** Ø12 mm round steel frame, hot-dip galvanized. **Powder coating:** RAL colour to choose. **Seating and Back-rest:** hard wooden slats untreated or treated. **Fixation:** fixed in the ground, surface mounting, free-standing.

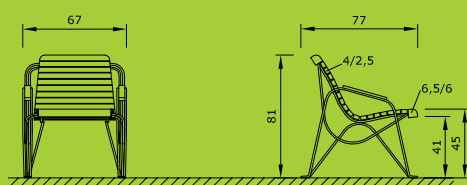

mod. 53

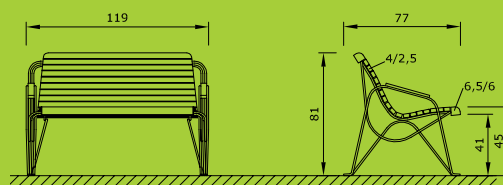

mod. 54

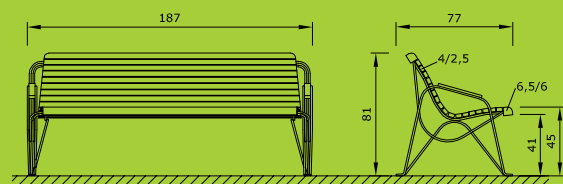

mod. 55

descrizione tecnica e disegni dwg | technische Beschreibung und dwg Zeichnungen | technical description and dwg drawings | description technique et dessins dwg: [www.euroform-w.com](http://www.euroform-w.com)





Park at the Castle of Brescia, Italy



Lotsenviertel, Cuxhaven, Germany

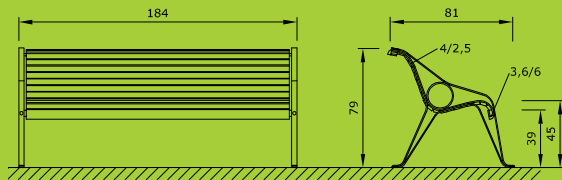

mod. 58

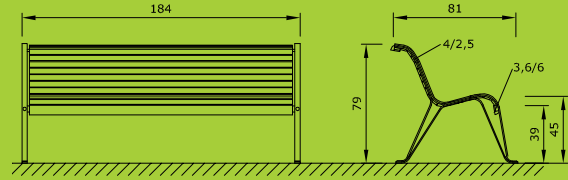

mod. 58/10

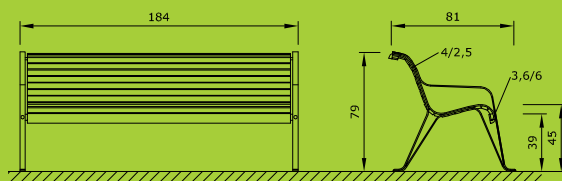

mod. 58/20

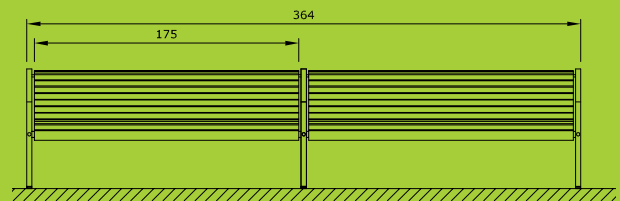

mod. 58D

descrizione tecnica e disegni dwg | technische Beschreibung und dwg Zeichnungen | technical description and dwg drawings | description technique et dessins dwg: [www.euroform-w.com](http://www.euroform-w.com)



## gala

mod. 58, 58/10, 58/20



Peso | Gewicht | Poids | Weight: 49 kg | 45 kg | 49 kg

## gala

mod. 58D



Peso | Gewicht | Poids | Weight: 80 kg



**Telaio:** ferro piatto 35x8 mm zincato a fuoco. **Trattamento a polvere:** Colori RAL a scelta. **Seduta e schienale:** legno duro non trattato o trattato. **Fissaggio:** in calcestruzzo, su pavimento solido o per collocamento libero.

**Ossature:** fer plat de 35x8 mm galvanisé à chaud. **Revêtement poudre polyester:** Coloris RAL au choix. **Assise et dossier:** Lattes en bois exotique sans traitement ou avec traitement de surface. **Scellement:** Dans le sol, en surface ou autostable.



**Gestell:** Flacheisen 35x8 mm, feuerverzinkt. **Pulverbeschichtung:** RAL-Farben nach Wahl. **Sitzauflage und Rückenlehne:** Hartholzbohlen unbehandelt oder behandelt. **Befestigung:** zum Einbetonieren, zum Aufschrauben oder zum freien Aufstellen.

**Frame:** flat steel frame 35x8 mm, hot-dip galvanized. **Powder coating:** RAL colour to choose. **Seating and Back-rest:** hard wooden slats untreated or treated. **Fixation:** fixed in the ground, surface mounting, free-standing.

## quattro

mod. 83

also for  
senior



Peso | Gewicht | Poids | Weight: 37 kg

## quattro

mod. 85

also for  
senior



Peso | Gewicht | Poids | Weight: 51 kg

## quattro

mod. 86



Peso | Gewicht | Poids | Weight: 43 kg

**Telaio:** tubo quadro d'acciaio 40x40 mm zincato a fuoco.  
**Trattamento a polvere:** Colori RAL a scelta. **Seduta e schienale:** legno duro non trattato o trattato. **Fissaggio:** in calcestruzzo, su pavimento solido o per collocamento libero.

**Ossature:** tube d'acier 40x40 mm galvanisé à chaud.  
**Revêtement poudre polyester:** Coloris RAL au choix. **Assise et dossier:** Lattes en bois exotique sans traitement ou avec traitement de surface. **Scellement:** Dans le sol, en surface ou autostable.

**Gestell:** Quadratrohr 40x40 mm feuerverzinkt. **Sitzauf-lage und Rückenlehne:** Hartholzbohlen unbehandelt oder behandelt. **Pulverbeschichtung:** RAL-Farben nach Wahl. **Befestigung:** zum Einbetonieren, zum Aufschrauben oder zum freien Aufstellen.

**Frame:** square steel 40x40 mm, hot-dip galvanized. **Powder coating:** RAL colour to choose. **Seating and Back-rest:** hard wooden slats untreated or treated. **Fixation:** fixed in the ground, surface mounting, free-standing.



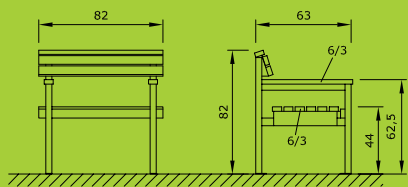

mod. 83

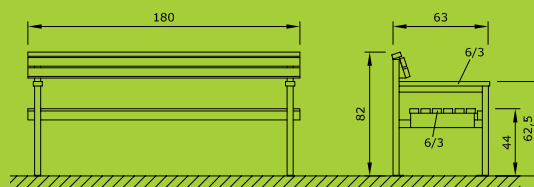

mod. 85

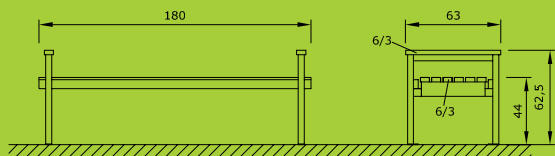

mod. 86

descrizione tecnica e disegni dwg | technische Beschreibung und dwg Zeichnungen | technical description and dwg drawings | description technique et dessins dwg: [www.euroform-w.com](http://www.euroform-w.com)



Park Lamborghini, Sant'Agata Bolognese, Bologna, Italy





Thermae, Merano, Italy



mod. 70/1



mod. 70M/9



mod. 70/3



mod. 70M/10



mod. 70M/5



mod. 70M/11



mod. 70M/6



mod. 70M/12



mod. 70M/7



mod. 70M/3



mod. 70M/8



snodo | Gelenk | élément articulé |  
hinge section - mod. 70M/14

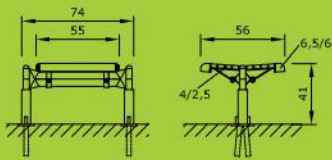

fisso | fest | fixe | fix

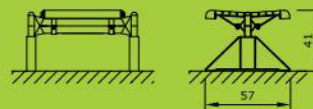

libero | freistehend | autostabile | free-standing

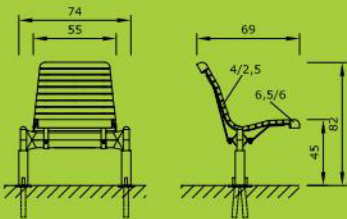

fisso | fest | fixe | fix

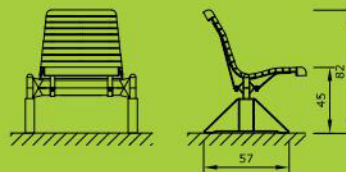

libero | freistehend | autostabile | free-standing

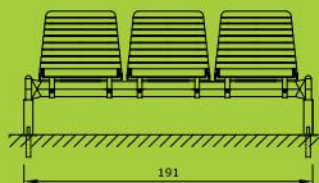
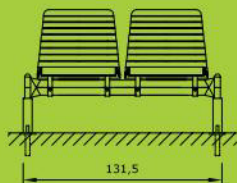

descrizione tecnica e disegni dwg | technische Beschreibung und dwg Zeichnungen | technical description  
and dwg drawings | description technique et dessins dwg: [www.euroform-w.com](http://www.euroform-w.com)





House for elderly, Schlema, Sachsen, Germany

## domino

mod. 70/1



## domino

mod. 70/3



## domino

mod. 70/1M

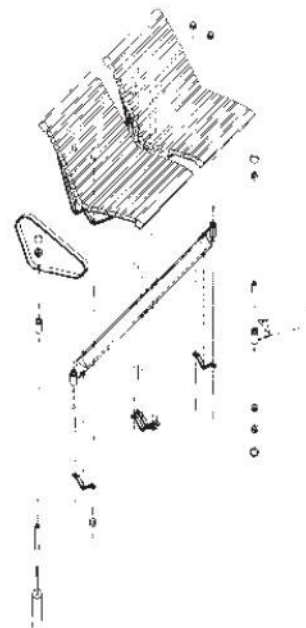

**Telaio:** ferro piatto 60x6 mm o tubolare d'acciaio Ø60 mm. **Trattamento a polvere:** Colori RAL a scelta. **Seduta e schienale:** legno duro non trattato o trattato. **Fissaggio:** in calcestruzzo, su pavimento solido o per collocamento libero.

**Ossature:** fer plat de 60x6 mm ou tube d'acier de Ø60 mm. **Revêtement poudre polyester:** Coloris RAL au choix. **Assise et dossier:** Lattes en bois exotique sans traitement ou avec traitement de surface. **Scellement:** Dans le sol, en surface ou autostable.

**Gestell:** Flacheisen 60x6 mm oder Stahlrohr Ø60 mm, feuerverzinkt. **Sitzaufgabe und Rückenlehne:** Hartholzbohlen unbehandelt oder behandelt. **Pulverbeschichtung:** RAL-Farben nach Wahl. **Befestigung:** zum Einbetonieren, zum Aufschrauben oder zum freien Aufstellen.

**Frame:** flat steel frame 60x6 mm or tubular steel Ø 60 mm, hot-dip galvanized. **Powder coating:** RAL colour to choose. **Seating and Back-rest:** hard wooden slats untreated or treated. **Fixation:** fixed in the ground, surface mounting, free-standing.



Pesaro Urbino, Italy



Ancona, Italy

## mimesi

mod. 4530



Peso | Gewicht | Poids | Weight: 118 kg

## clip

mod. 4512



Peso | Gewicht | Poids | Weight: 99 kg

## clip

mod. 4515



Peso | Gewicht | Poids | Weight: 185 kg

## cryou

mod. 4520, 4525



Peso | Gewicht | Poids | Weight: 47 kg | 58 kg

**Telaio:** lamiera d'acciaio spessore 10 mm (Clip) e 6 mm (Mimesi, Cryou), zincato a fuoco. **Trattamento a polvere:** Colori RAL a scelta. **Seduta e schienale:** legno duro non trattato o trattato. **Fissaggio:** in calcestruzzo, su pavimento solido o per collocamento libero.

**Ossature:** Fer plat 10 mm (Clip) et 6 mm (Mimesi, Cryou), galvanisé à chaud. **Revêtement poudre polyester:** Coloris RAL au choix. **Assise et dossier:** Lattes en bois exotique sans traitement ou avec traitement de surface. **Scellement:** Dans le sol, en surface ou autostable.

**Gestell:** Stahlblech 10 mm (Clip) und 6 mm (Mimesi, Cryou), feuerverzinkt. **Sitzaufgabe und Rückenlehne:** Hartholzbohlen unbehandelt oder behandelt. **Pulverbeschichtung:** RAL-Farben nach Wahl. **Befestigung:** zum Einbetonieren, zum Aufschrauben oder zum freien Aufstellen.

**Frame:** steel sheet 10 mm (Clip) and 6 mm (Mimesi, Cryou) hot-dip galvanized. **Powder coating:** RAL colour to choose. **Seating and Back-rest:** hard wooden slats untreated or treated. **Fixation:** fixed in the ground, surface mounting, free-standing.



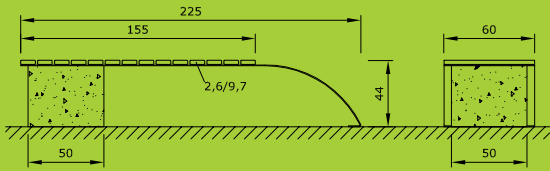

mod. 4530

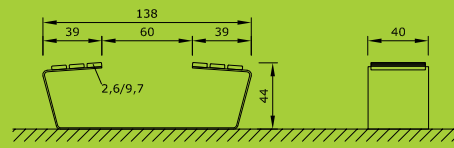

mod. 4512

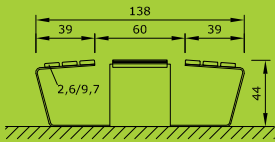

mod. 4515

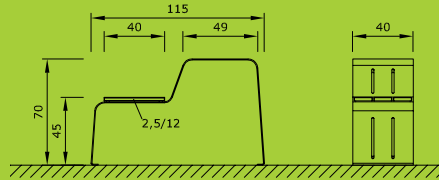

mod. 4520

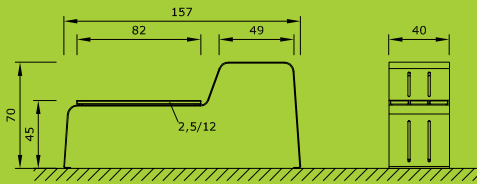

mod. 4525



descrizione tecnica e disegni dwg | technische Beschreibung und dwg Zeichnungen | technical description and dwg drawings | description technique et dessins dwg: [www.euroform-w.com](http://www.euroform-w.com)



## stilo

mod. 35



Peso | Gewicht | Poids | Weight: 36 kg

## stilo

mod. 35F



Peso | Gewicht | Poids | Weight: 36 kg

## stilo fitness

mod. 35P, 35FP

also for  
senior

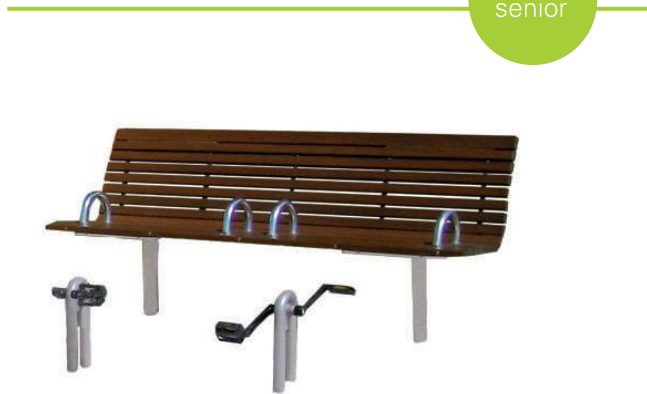

Peso | Gewicht | Poids | Weight: 52 kg

**Telaio:** tubo d'acciaio Ø18 mm e Ø70 mm zincato a fuoco.  
**Trattamento a polvere:** Colori RAL a scelta. **Seduta e schienale:** legno duro non trattato o trattato. **Fissaggio:** in calcestruzzo, su pavimento solido o per collocamento libero.

**Ossature:** tube d'acier de Ø18 mm et Ø70 mm galvanisé à chaud. **Revêtement poudre polyester:** Coloris RAL au choix. **Assise et dossier:** Lattes en bois exotique sans traitement ou avec traitement de surface. **Scellement:** Dans le sol, en surface ou autostable.

**Gestell:** Stahlrohr Ø18 mm und Ø70 mm feuerverzinkt.  
**Sitzauflage und Rückenlehne:** Hartholzbohlen unbehandelt oder behandelt. **Pulverbeschichtung:** RAL-Farben nach Wahl. **Befestigung:** zum Einbetonieren, zum Aufschrauben oder zum freien Aufstellen.

**Frame:** tubular steel Ø18 mm and Ø70 mm, hot-dip galvanized. **Powder coating:** RAL colour to choose. **Seating and Back-rest:** hard wooden slats untreated or treated. **Fixation:** fixed in the ground, surface mounting, free-standing.

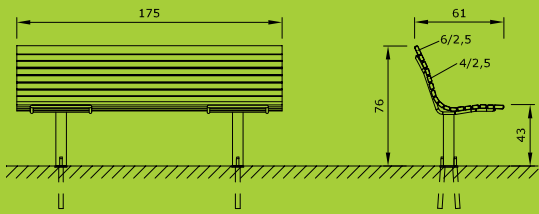

mod. 35

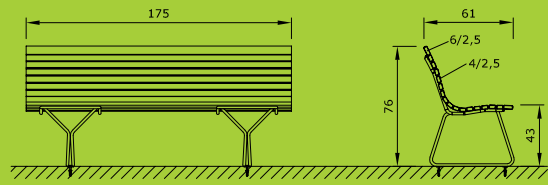

mod. 35F

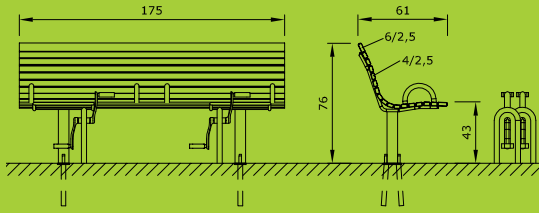

mod. 35P

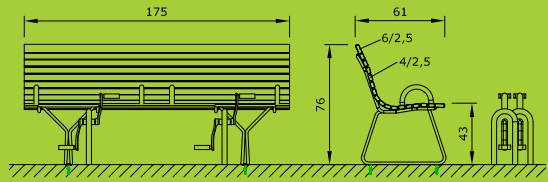

mod. 35FP

descrizione tecnica e disegni dwg | technische Beschreibung und dwg Zeichnungen | technical description and dwg drawings | description technique et dessins dwg: [www.euroform-w.com](http://www.euroform-w.com)



Italy

## block

mod. 90

---



Peso | Gewicht | Poids | Weight: 61 kg | 68 kg  
Lunghezza | Länge | Longueur | Length: 200 | 230 cm

## block

mod. 90L

---



Peso | Gewicht | Poids | Weight: 70 kg | 85 kg  
Lunghezza | Länge | Longueur | Length: 200 | 230 cm

## block

mod. 90D

---



Peso | Gewicht | Poids | Weight: 130 kg | 138 kg  
Lunghezza | Länge | Longueur | Length: 200 | 230 cm

**Telaio:** lamiera decapata e stampata da 2 mm zincata a fuoco. **Trattamento a polvere:** Colori RAL a scelta. **Sedute e schienale:** legno duro non trattato o trattato. **Fissaggio:** in calcestruzzo, su pavimento solido o per collocamento libero.

**Ossature:** acier 2 mm galvanisé à chaud. **Revêtement poudre polyester:** Coloris RAL au choix. **Assise et dossier:** Lattes en bois exotique sans traitement ou avec traitement de surface. **Scellement:** Dans le sol, en surface ou auto-stable.

**Gestell:** Stahlblech 2 mm feuerverzinkt. **Sitzaufgabe und Rückenlehne:** Hartholzbohlen unbehandelt oder behandelt. **Pulverbeschichtung:** RAL-Farben nach Wahl. **Befestigung:** zum Einbetonieren, zum Aufschrauben oder zum freien Aufstellen.

**Frame:** 2 mm sheet steel, hot-dip galvanized. **Powder coating:** RAL colour to choose. **Seating and Back-rest:** hard wooden slats untreated or treated. **Fixation:** fixed in the ground, surface mounting, free-standing.

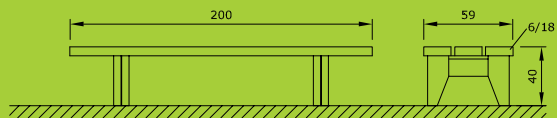

mod. 90

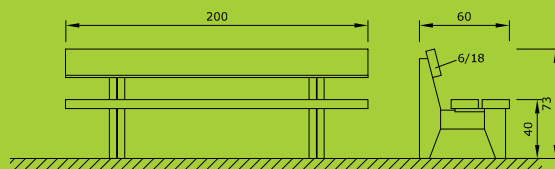

mod. 90L

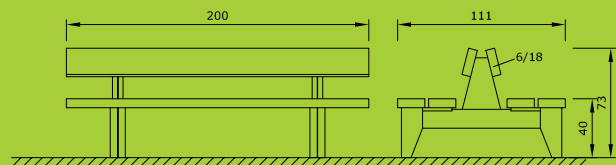

mod. 90D

descrizione tecnica e disegni dwg | technische Beschreibung und dwg Zeichnungen | technical description and dwg drawings | description technique et dessins dwg: [www.euroform-w.com](http://www.euroform-w.com)



Cisternini, Brindisi, Italy

## block

mod. 99F, 99FL



Peso | Gewicht | Poids | Weight: 16,5 kg  
Lunghezza | Länge | Longueur | Length: 125 cm

## block

mod. 99



Peso | Gewicht | Poids | Weight: 23 kg | 27 kg  
Lunghezza | Länge | Longueur | Length: 200 cm | 230 cm

## block

mod. 99FU, 99FULi, 99FULa



**Telaio:** profili flessibili lamiera zincata da 2 mm (mod. 99F), tubi tondi Ø30 mm e tubi quadri 30 mm (mod. 99FU, 99FULi, 99FULa). **Trattamento a polvere:** Colori RAL a scelta. **Seduta e schienale:** legno duro non trattato o trattato. **Fissaggio:** in calcestruzzo, su pavimento solido o per collocamento libero.

**Ossature:** profilés flexibles en acier galvanisé de 2 mm (mod. 99F), tubes ronds Ø30 mm et tubes carrés de 30 mm (mod. 99FU, 99FULi, 99FULa). **Revêtement poudre polyester:** Coloris RAL au choix. **Assise et dossier:** Lattes en bois exotique sans traitement ou avec traitement de surface. **Scellement:** Dans le sol, en surface ou autostable.

**Gestell:** flexible Profile verzinktes Stahlblech 2 mm (mod. 99F), Rundrohre Ø30 mm und Rechteckrohre 30 mm (mod. 99FU, 99FULi, 99FULa). **Pulverbeschichtung:** RAL-Farben nach Wahl. **Sitzauflage und Rückenlehne:** Hartholzbohlen unbehandelt oder behandelt. **Befestigung:** zum Einbetonieren, zum Aufschrauben oder zum freien Aufstellen.

**Frame:** flexible galvanized steel profiles of 2 mm (mod. 99F), round tubes Ø 30 mm and square tubes 30 mm (mod. 99FU, 99FULi, 99FULa). **Powder coating:** RAL colour to choose. **Seating and Back-rest:** hard wooden slats untreated or treated. **Fixation:** fixed in the ground, surface mounting, free-standing.

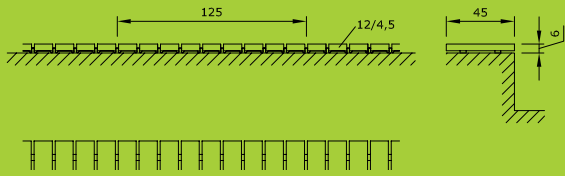

mod. 99F

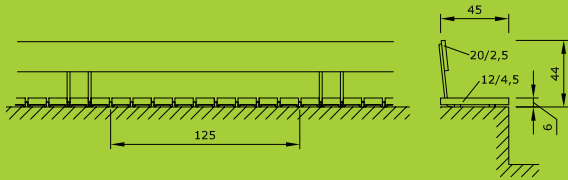

mod. 99FL

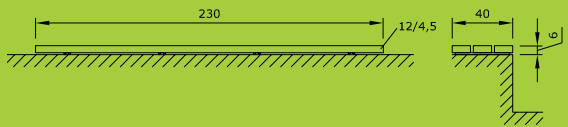

mod. 99

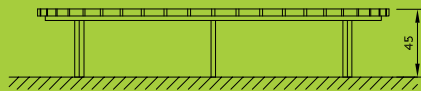
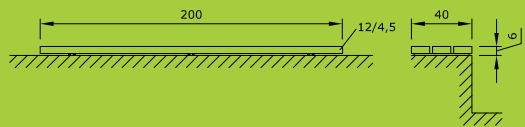

mod. 99FU

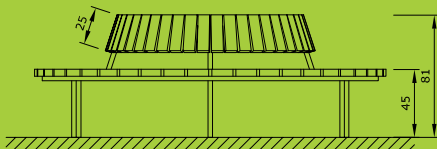

mod. 99FULi

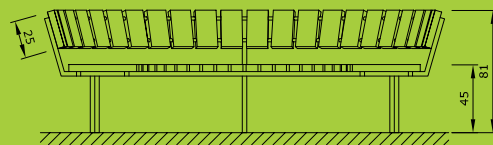

mod. 99FULa



Place of the Church, Ciriè, Torino, Italy



Area Ex Albert, Torino, Italy





Reinach, Basel, Switzerland



Torino, Italy

## classic

mod. 22



Peso | Gewicht | Poids | Weight: 34 kg

**Telaio:** tubo d'acciaio Ø18 mm, zincato a fuoco. **Trattamento a polvere:** Colori RAL a scelta. **Seduta e schienale:** legno duro non trattato o trattato. **Fissaggio:** in calcestruzzo, su pavimento solido o per collocamento libero.

**Ossature:** tube d'acier Ø18 mm, galvanisé à chaud. **Revêtement poudre polyester:** Coloris RAL au choix. **Assise et dossier:** Lattes en bois exotique sans traitement ou avec traitement de surface. **Scellement:** Dans le sol, en surface ou autostable.

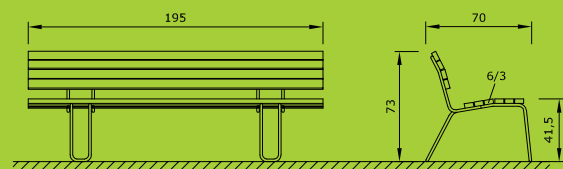

mod. 22

## classic

mod. 33



Peso | Gewicht | Poids | Weight: 33 kg

**Gestell:** Stahlrohr Ø18 mm, feuerverzinkt. **Sitzaufgabe und Rückenlehne:** Hartholzbohlen unbehandelt oder behandelt. **Pulverbeschichtung:** RAL-Farben nach Wahl. **Befestigung:** zum Einbetonieren, zum Aufschrauben oder zum freien Aufstellen.

**Frame:** steel tube Ø18 mm, hot-dip galvanized. **Powder coating:** RAL colour to choose. **Seating and Back-rest:** hard wooden slats untreated or treated. **Fixation:** fixed in the ground, surface mounting, free-standing.

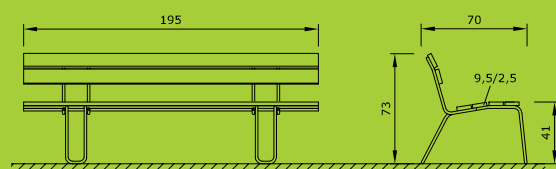

mod. 33

descrizione tecnica e disegni dwg | technische Beschreibung und dwg Zeichnungen | technical description and dwg drawings | description technique et dessins dwg: [www.euroform-w.com](http://www.euroform-w.com)





Torino, Italy

## palazzo light

mod. 48



Peso | Gewicht | Poids | Weight: 55 kg

**Telaio:** ferro piatto 10x80 mm (mod. 49) e 6x40 mm (mod. 48). Rinforzo orizzontale in tubo tondo Ø30 mm, zincato (mod. 48). **Trattamento a polvere:** Colori RAL a scelta. **Seduta e schienale:** legno duro non trattato o trattato. **Fissaggio:** in calcestruzzo, su pavimento solido o per collocamento libero.

**Ossature:** fer plat 10x80 mm (mod. 49) e 6x40 mm (mod. 48), galvanisé à chaud. Barre transversale en tube rond Ø30 mm (mod. 48). **Revêtement poudre polyester:** Coloris RAL au choix. **Assise et dossier:** Lattes en bois exotique sans traitement ou avec traitement de surface. **Scellement:** Dans le sol, en surface ou autostable.

## palazzo light

mod. 49



Peso | Gewicht | Poids | Weight: 63 kg

**Gestell:** Flacheisen 10x80 mm (mod. 49) und 6x40 mm (mod. 48). Queraussteifung mittels Rundrohr Ø 30 mm, verzinkt (mod. 48). **Pulverbeschichtung:** RAL-Farben nach Wahl. **Sitzaufgabe und Rückenlehne:** Hartholzbohlen unbehandelt oder behandelt. **Befestigung:** zum Einbetonieren, zum Aufschrauben oder zum freien Aufstellen.

**Frame:** flat bar 10x80 mm (mod. 49) and 6x40 mm (mod. 48). Cross-support Ø30 mm circular tubing, galvanized (mod. 48). **Powder coating:** RAL colour to choose. **Seating and Back-rest:** hard wooden slats untreated or treated. **Fixation:** fixed in the ground, surface mounting, free-standing.

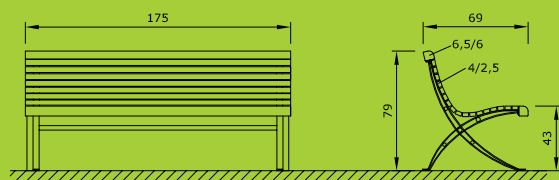

mod. 48

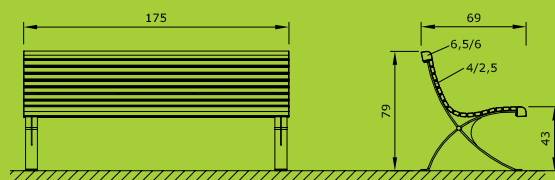

mod. 49

descrizione tecnica e disegni dwg | technische Beschreibung und dwg Zeichnungen | technical description and dwg drawings | description technique et dessins dwg: [www.euroform-w.com](http://www.euroform-w.com)





Beekhuizen, Holland

fritz

mod. 1200



Peso | Gewicht | Poids | Weight: 53 kg

**Copertura e telaio:** pali in tubo d'acciaio Ø100 mm. Parte laterale in alluminio fusione in sabbia resistente alle acque saline. **Trattamento a polvere:** Colori RAL a scelta. **Seduta e schienale:** legno duro non trattato o trattato. **Fissaggio:** in calcestruzzo.

**Cap et le ossature:** Posters faite de tubulaire Ø100 mm. Partie latérale de aluminium sablé résistant à l'eau de mer. **Revêtement poudre polyester:** Coloris RAL au choix. **Assise et dossier:** Lattes en bois exotique sans traitement ou avec traitement de surface. **Scellement:** Dans le sol.

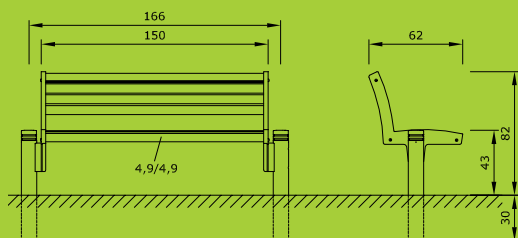

mod. 1200

fritz

mod. 1205



Peso | Gewicht | Poids | Weight: 39 kg

**Kappe und Gestell:** Pfosten aus Rundrohr Ø100 mm. Seitenteil seewasserbeständige Aluminiumsandgusslegierung. **Pulverbeschichtung:** RAL-Farben nach Wahl. **Sitzauflage und Rückenlehne:** Hartholzbohlen unbehandelt oder behandelt. **Befestigung:** zum Einbetonieren.

**Cover and frame:** Posts in tube circular Ø100 mm. Side part in aluminum alloy sand casting resistant against seawater. **Powder coating:** RAL colour to choose. **Seating and Back-rest:** hard wooden slats untreated or treated. **Fixation:** fixed in the ground.

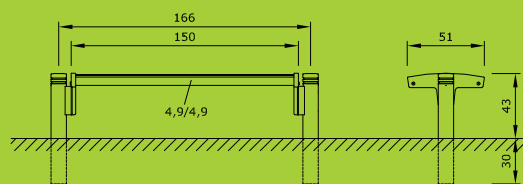

mod. 1205

descrizione tecnica e disegni dwg | technische Beschreibung und dwg Zeichnungen | technical description and dwg drawings | description technique et dessins dwg: [www.euroform-w.com](http://www.euroform-w.com)





## aron

mod. 1100



Peso | Gewicht | Poids | Weight: 127 kg

## aron

mod. 1105



Peso | Gewicht | Poids | Weight: 91 kg

## linus

mod. 68



Peso | Gewicht | Poids | Weight: 59 kg



**ARON: Telaio:** lamiera d'acciaio 10x8 mm zincato.  
**LINUS: Telaio:** ferro piatto 10x50 mm zincato a fuoco.  
**Trattamento a polvere:** Colori RAL a scelta. **Seduta e schienale:** legno duro non trattato o trattato. **Fissaggio:** in calcestruzzo, su pavimento solido o per collocamento libero.

**ARON: Ossature:** en acier 10+8 mm galvanisé.  
**LINUS: Ossature:** fer plat 10x50 mm galvanisé à chaud.  
**Revêtement poudre polyester:** Coloris RAL au choix. **Assise et dossier:** Lattes en bois exotique sans traitement ou avec traitement de surface. **Scellement:** Dans le sol, en surface ou autostable.

**ARON: Gestell:** Stahlblech 10+8 mm verzinkt.  
**LINUS: Gestell:** Flacheisen 10x50 mm feuerverzinkt.  
**Pulverbeschichtung:** RAL-Farben nach Wahl. **Sitzauflage und Rückenlehne:** Hartholzbohlen unbehandelt oder behandelt. **Befestigung:** zum Einbetonieren, zum Aufschrauben oder zum freien Aufstellen.

**ARON: Frame:** steel sheet 10+8 mm galvanized.  
**LINUS: Frame:** flat steel 10x50 mm hot-dip galvanized.  
Powder coating: RAL colour to choose. **Seating and Backrest:** hard wooden slats untreated or treated. **Fixation:** fixed in the ground, surface mounting, free-standing.



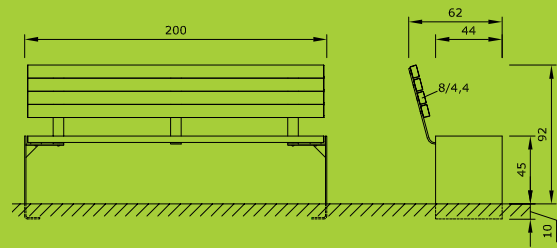

mod. 1100

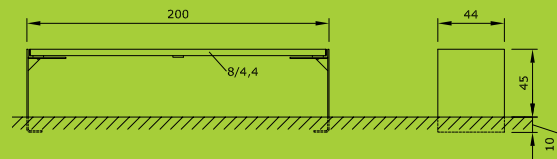

mod. 1105

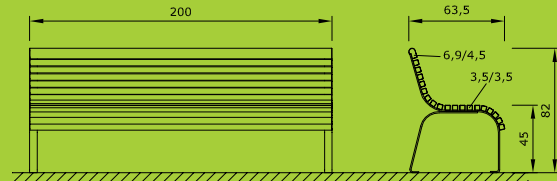

mod. 68



descrizione tecnica e disegni dwg  
 technische Beschreibung und dwg Zeichnungen  
 technical description and dwg drawings  
 description technique et dessins dwg:  
[www.euroform-w.com](http://www.euroform-w.com)







# benches in cast iron

panchine in ghisa | bänke in gusseisen | bancs avec piètements en fonte

Le panchine in ghisa di euroform w interpretano questo materiale in una forma nuova, leggera e moderna. Grazie alla combinazione con una seduta ergonomica, queste panchine invitano ad una sosta piacevole e rilassante. I nostri elementi in ghisa sono realizzati al 100% in Italia.

euroform w Gusseisenbänke interpretieren dieses Material in einer neuen, leichten und modernen Form. Durch die Verbindung mit einer ergonomischen Sitzauflage, laden diese Banksysteme zum angenehmen Verweilen ein. Unsere Gusseisenelemente sind zu 100% in Italien hergestellt.

Les bancs en fonte d'Euroform w interprètent ce matériel sous une nouvelle forme, légère et moderne. Grâce à la combinaison avec un siège ergonomique, ces bancs sont une invitation pour un séjour plaisant et relaxant. Nos éléments en fonte sont réalisés 100 % en Italie.

euroform w cast iron benches interpret this material in a new, light and modern form. By combining this material with an ergonomic seating, they invite you for a pleasant stay. Our cast iron elements are made 100% in Italy.

# ghisa | gusseisen | piètements en fonte | cast iron

La ghisa si presta molto bene per produrre elementi di arredo urbano grazie alla sua stabilità ed alla sua conformabilità. La ghisa è stata da sempre usata per gli spazi pubblici dei centri storici: da oggi, con un design più moderno, la proponiamo per ogni ambiente cittadino.

Gusseisen bietet sich aufgrund seiner Eigenschaften wie Stabilität und seiner guten Formbarkeit für Produkte im Freiraum an. Gusseisen wurde seit jeher für Freiraumprodukte vor allem in historischen Zentren verwendet und findet heutzutage wieder in moderneren Formen seinen Einsatz bei der Planung von öffentlichen Parks und Plätzen.

Le matériau fonte est très approprié pour les produits de l'espace urbain grâce à ses propriétés dont la stabilité et sa coulabilité. La fonte est utilisée depuis longtemps pour le mobilier urbain, principalement dans les centres historiques, et à présent elle est utilisée de nouveau sous des formes plus modernes dans la conception de parcs et de places publiques.

Cast iron is due to its properties such as stability and its good castability suitable for products in the urban space. Cast iron has been used since long time for products in the urban space, primarily in historical centers and is now used again in more modern forms in the planning of public parks and squares.

## palazzo

mod. 50



Peso | Gewicht | Poids | Weight: 68 kg

**Telaio:** ghisa grigia a grafite lamellare. Rinforzo in lamiera d'acciaio (mod. 51). **Trattamento a polvere:** Colori RAL a scelta. **Seduta e schienale:** legno duro non trattato o trattato. **Fissaggio:** in calcestruzzo, su pavimento solido o per collocamento libero.

**Ossature:** fonte grise. Renfort horizontal tole d'acier (mod. 51). **Revêtement poudre polyester:** Coloris RAL au choix. **Assise et dossier:** Lattes en bois exotique sans traitement ou avec traitement. **Scellement:** Dans le sol, en surface ou autostable.

## epoca

mod. 51



Peso | Gewicht | Poids | Weight: 70 kg

**Gestell:** Grauguss mit Lamellengraphit. Querverstrebung aus Stahlblech (mod. 51). **Pulverbe-schichtung:** RAL-Farben nach Wahl. **Sitzaufgabe und Rückenlehne:** Hartholzbohlen unbehandelt oder behandelt. **Befestigung:** zum Einbetonieren, zum Aufschrauben oder zum freien Aufstellen.

**Frame:** grey lamellar graphite cast iron. Steel sheet reinforcement (mod. 51). **Powder coating:** RAL colour to choose. **Seating and Back-rest:** hard wooden slats untreated or treated. **Fixation:** fixed in the ground, surface mounting, free-standing.

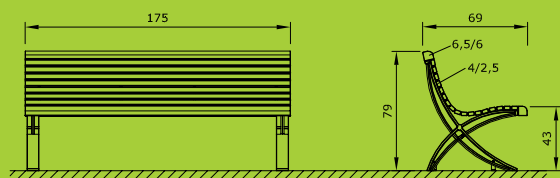

mod. 50

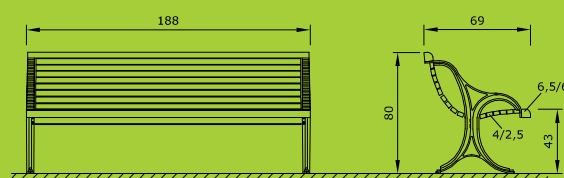

mod. 51

descrizione tecnica e disegni dwg | technische Beschreibung und dwg Zeichnungen | technical description and dwg drawings | description technique et dessins dwg: [www.euroform-w.com](http://www.euroform-w.com)



# ancora

mod. 52



Peso | Gewicht | Poids | Weight: 66 kg

**Telaio:** in ghisa grigia a grafite lamellare. Rinforzo in tubo tondo Ø30 mm. **Trattamento a polvere:** Colori RAL a scelta. **Seduta e schienale:** legno duro non trattato o trattato. **Fissaggio:** in calcestruzzo, su pavimento solido.

**Ossature:** en fonte grise. Renfort horizontal tube tond Ø30 mm. **Revêtement poudre polyester:** Coloris RAL au choix. **Assise et dossier:** Lattes en bois exotique sans traitement ou avec traitement. **Scellement:** Dans le sol, en surface.

**Gestell:** Grauguss mit Lamellengraphit, Querverstrebung aus Rundrohr Ø30 mm. **Pulverbeschichtung:** RAL-Farben nach Wahl. **Sitzauflage und Rückenlehne:** Hartholzbohlen unbehandelt oder behandelt. **Befestigung:** zum Einbetonieren, zum Aufschrauben.

**Frame:** grey lamellar graphite cast iron. Reinforcement in tubular steel Ø30 mm. **Powder coating:** RAL colour to choose. **Seating and Back-rest:** hard wooden slats untreated or treated. **Fixation:** fixed in the ground, surface mounting.

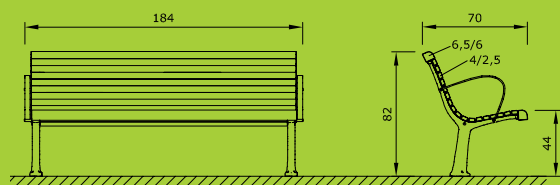

mod. 52

descrizione tecnica e disegni dwg | technische Beschreibung und dwg Zeichnungen | technical description and dwg drawings | description technique et dessins dwg: [www.euroform-w.com](http://www.euroform-w.com)





Radolfzell, Baden-Württemberg, Germany



Ramsey, Isle of Man, UK







# benches in metal

panchine in metallo | banksysteme in metall | bancs en métal

I sedili metallici di euroform w vengono prodotti soprattutto in lamiera stirata, poichè criteri come durata, sicurezza contro atti di vandalismo e massima stabilità per noi sono importanti. Ma anche la presa e il comfort di seduta per noi sono decisivi. La lamiera stirata offre oltre all'estetica della filigrana anche molti altri vantaggi dal punto di vista funzionale.

Die Sitzauflagen der Metallbänke von euroform w werden vorwiegend aus Streckmetall gefertigt, da Kriterien wie Lebensdauer, Vandalismussicherheit und höchste Stabilität für uns entscheidend sind. Griffigkeit und ein angenehmer Sitzkomfort sind für uns ausserdem entscheidend. Das Streckmetall bietet neben der filigranen Ästhetik auch funktionell viele weitere Vorzüge.

Les bancs métalliques d'euroform w sont principalement produits en tôle étirée puisque des critères comme la durée, la sécurité contre des actes de vandalisme et une stabilité maximale sont importants pour nous. Mais la prise et le confort de l'assise sont également décisifs pour nous. La tôle étirée offre, au-delà de l'esthétique du filigrane, bien d'autres avantages du point de vue fonctionnel.

The metal seats of euroform w are primarily made of expanded metal, because criteria such as durability, vandalism security and high stability for us are important. Also the grip and the seating comfort for us are important. This material offers not only a delicate aesthetic, but also many functional advantages.

## Zincatura a caldo

La zincatura a caldo secondo la norma UNI EN ISO1461 garantisce una protezione ottimale contro la corrosione. Lo spessore della zincatura è minimo 55 micron. La struttura della superficie non è sempre liscia ma spesso leggermente scabrosa. Questa è una caratteristica tipica della zincatura a caldo e non costituisce un difetto. Superfici zincate a caldo diventano grigie opache dopo un breve periodo di tempo e restano così nel tempo.

## Trattamento a polvere

Le parti zincate a caldo possono anche essere fornite con trattamento a polvere in quasi tutti i colori RAL (colori perlati e brillanti) anche nel colore speciale effetto "Corten". Lo spessore dello strato di polvere è di almeno 80 micron (500 ore di test in nebbia salina secondo la norma DIN 50021 o ISO 9227-SS UV - Resistenza della polvere secondo la tabella di garanzia Qualicoat). Se il rivestimento è danneggiato, è consigliabile trattarlo immediatamente con una vernice idonea per prevenire danni secondari.

## Feuerverzinkung

Durch die Feuerverzinkung gemäß UNI EN ISO1461 wird optimaler Korrosionsschutz gewährleistet, wobei der durchschnittlich aufgetragene Zinkfilm 55 Mikron beträgt. Die Oberflächenstruktur ist nach dem Feuerverzinken nicht immer glatt sondern oft leicht wellig. Dies ist eine typische Eigenschaft der Feuerverzinkung und stellt keinen Mangel dar. Verzinkte Oberflächen werden bereits nach kurzer Zeit gräulich matt und bleiben so auf Dauer.

## Pulverbeschichtung

Verzinkte Metallteile können auch mit einer Pulverbeschichtung geliefert werden, wobei die Schichtdicke des Pulvers mind. 80 Micron beträgt. (500 h Salzsprühnebeltest lt. DIN 50021-SS oder ISO 9227 UV - Beständigkeit des Pulvers lt. Garantietabelle Qualicoat). Die Lieferung von pulverbeschichteten Metallteilen kann in nahezu allen RAL Farben (ausgenommen Perl- und Leuchtfarben) aber auch in der Spezialfarbe „Corten-Effekt“ erfolgen. Sollte die Farbbeschichtung eines Stadtmöbels beschädigt werden, empfiehlt sich zur Vermeidung von Folgeschäden eine umgehende Behandlung mit einem geeigneten Lack.

## Galvanisation à chaud

La galvanisation à chaud selon la norme UNI EN ISO 1461 garantit une protection optimale contre la corrosion. L'épaisseur de la galvanisation est au minimum de 55 microns. La structure de la surface n'est pas toujours lisse mais souvent légèrement ondulée. Ceci est une caractéristique typique de la galvanisation à chaud et ne constitue pas un défaut. Les surfaces galvanisées à chaud deviennent grises opaques après une courte période et restent ainsi le long du temps.

## Traitement à poudre

Les parties galvanisées à chaud peuvent aussi être fournies avec un traitement à poudre dans quasiment toutes les couleurs RAL (couleurs perlés et brillantes), même dans la couleur spéciale effet « Corten ». L'épaisseur de la couche de poudre est d'au moins 80 microns (500 heures de test en brume saline selon la norme DIN 50021 ou ISO 9227-SS UV - Résistance de la poudre selon le tableau de garantie Qualicoat). Si le revêtement est endommagé, il est conseillé de le traiter immédiatement avec un vernis adapté afin de prévenir les dommages secondaires.

## Hot-dip galvanizing

Hot-dip galvanizing in accordance with the UNI EN ISO1461 ensures optimum corrosion protection. The applied layer has a minimum thickness of 55 micron. The surface structure is not always smooth but often slightly wavy. This is a typical characteristic of the hot-dip galvanizing and does not constitute a defect. Hot-dip galvanized surfaces become grey matt after a short time and remain so over time.

## Powder coating

Hot-dip galvanized metal parts can also be supplied additionally powder coated. The thickness of the powder layer is at least 80 microns. (500 hours salt spray test according to DIN 50021 or ISO 9227-SS UV - resistance of the powder according to Qualicoat warranty table). Metal parts can be delivered powder coated in almost all RAL colours (excepted luminous and pearl colours) and also in the special colour "Corten effect". If the coating is damaged immediate treatment with a suitable paint is recommended to prevent secondary damage.

## lineaseduta light

mod. 375LM



Peso | Gewicht | Poids | Weight: 59 kg

**Telaio:** ferro piatto 10x60 mm zincato. **Seduta e schienale:** lamiera forata spess. 3 mm, fori 20x20 mm, zincato. **Trattamento a polvere:** colori RAL a scelta. **Fissaggio:** in calcestruzzo, su pavimento solido o per collocamento libero.

**Ossature:** Fer plat 10x60 mm, galvanisé. **Revêtement poudre polyester:** Coloris RAL au choix. **Assise et dossier:** Tôle perforée 3 mm - perforations 20x20 mm, galvanisé. **Scellement:** dans le sol, en surface ou autostable.

## lineapanca light

mod. 370LM



Peso | Gewicht | Poids | Weight: 42 kg

**Gestell:** Flacheisen 10x60 mm, verzinkt. **Sitzaufgabe und Rückenlehne:** Lochblech 3 mm, Quadratlöcher 20x20 mm, verzinkt. **Pulverbeschichtung:** RAL-Farben nach Wahl. **Befestigung:** zum Einbetonieren, zum Aufschrauben oder zum freien Aufstellen.

**Frame:** flat bar 10x60 mm, galvanized. **Seating and backrest:** perforated metal 3 mm, holes 20x20 mm, galvanized. **Powder coating:** RAL colour to choose. **Fixation:** fixed in the ground, surface mounting, **free-standing**.

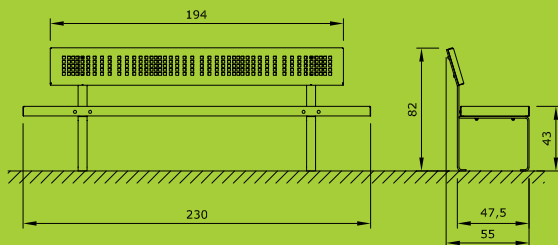

mod. 375LM

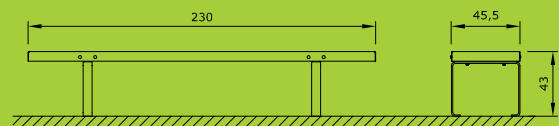

mod. 370LM

## linea

mod. 1305



Peso | Gewicht | Poids | Weight: 47 kg

**Telaio, seduta, schienale:** lamiera d'acciaio spess. 6 mm zincato a fuoco. **Trattamento a polvere:** Colori RAL a scelta. **Fissaggio:** in calcestruzzo, su pavimento solido o per collocamento libero.

**Ossature, assise, dossier:** acier 6 mm galvanisé à chaud. **Revêtement poudre polyester:** Coloris RAL au choix. **Scellement:** Dans le sol, en surface ou autostable.

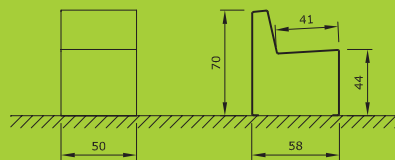

mod. 1305

## linea

mod. 1340



Peso | Gewicht | Poids | Weight: 31 kg

**Gestell, Sitzauflage, Rückenlehne:** Stahlblech 6 mm feuerverzinkt. **Pulverbeschichtung:** RAL-Farben nach Wahl. **Befestigung:** zum Einbetonieren, zum Aufschrauben oder zum freien Aufstellen.

**Frame, Seating, Back-rest:** steel sheet 6 mm, hot-dip galvanized. **Powder coating:** RAL colour to choose. **Fixation:** fixed in the ground, surface mounting, free-standing.



mod. 1340



Barbaresco, Cuneo, Italy



## contour

mod. 319MS, 320MS, 321MS  
mod. 319MS/F, 320MS/F, 321MS/F



also  
for  
senior

Peso | Gewicht | Poids | Weight: 20 kg | 30 kg | 49 kg

## contour

mod. 322M, 322MF



Peso | Gewicht | Poids | Weight: 17 kg

## contour

mod. 323M, 323MF



Peso | Gewicht | Poids | Weight: 27 kg

## contour

mod. 325M, 325MF



Peso | Gewicht | Poids | Weight: 41 kg

**Telaio:** tubo d'acciaio Ø30 mm zincato a fuoco. **Trattamento a polvere:** Colori RAL a scelta. **Seduta e schienale:** lamiera stirata spess. 3 mm, bordata spess. 8 mm. **Fissaggio:** in calcestruzzo, su pavimento solido o per collocamento libero.

**Ossature:** tube d'acier de Ø30 mm galvanisé à chaud. **Revêtement poudre polyester:** Coloris RAL au choix. **Assise et dossier:** en métal déployé - épaisseur 3 mm avec un rebord de 8 mm d'épaisseur. **Scellement:** Dans le sol, en surface ou autostable.

**Gestell:** Stahlrohr Ø30 mm feuerverzinkt. **Pulverbeschichtung:** RAL-Farben nach Wahl. **Sitzauflage und Rückenlehne:** Streckmetall 3 mm, mit U-Profil 8 mm gerändelt. **Befestigung:** zum Einbetonieren, zum Aufschrauben oder zum freien Aufstellen.

**Frame:** tubular steel frame Ø30 mm, hot-dip galvanized. **Powder coating:** RAL colour to choose. **Seating and Backrest:** expanded metal thickness 3 mm, rounded-off edging thickness 8 mm. **Fixation:** fixed in the ground, surface mounting, free-standing.

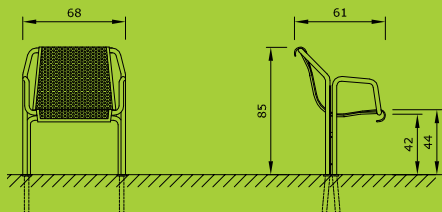

mod. 319MS

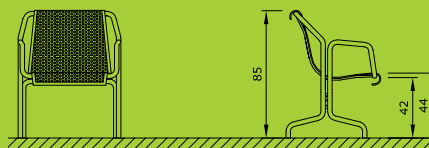

mod. 319MS/F

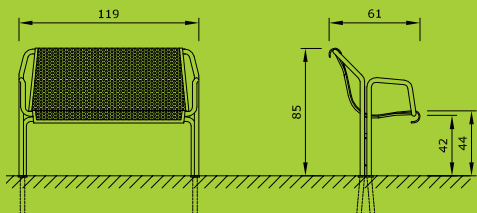

mod. 320MS

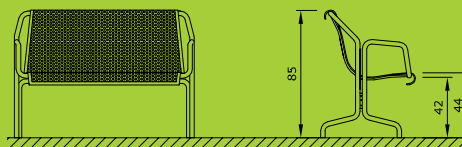

mod. 320MS/F

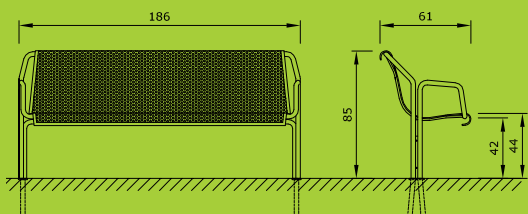

mod. 321MS

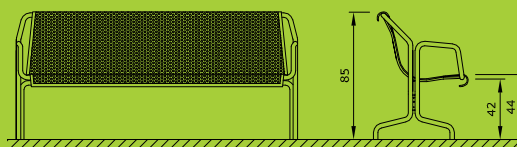

mod. 321MS/F

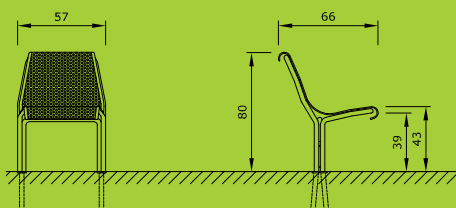

mod. 322M

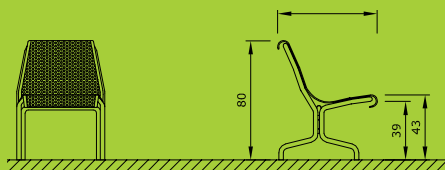

mod. 322M/F

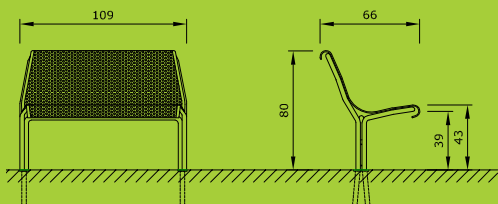

mod. 323M

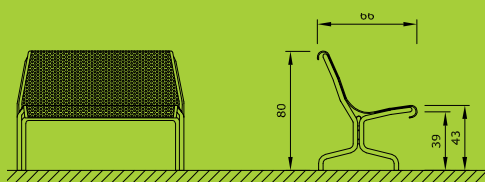

mod. 323M/F

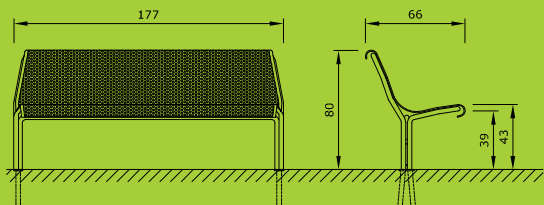

mod. 325M

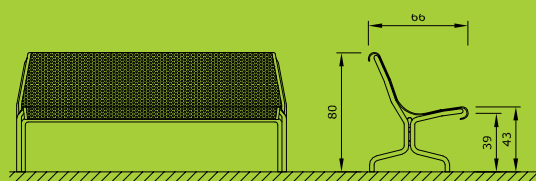

mod. 325M/F

## contour

mod. 324M, 324MF



Peso | Gewicht | Poids | Weight: 25 kg

**Telaio:** tubo d'acciaio Ø30 mm zincato a fuoco. **Trattamento a polvere:** Colori RAL a scelta. **Seduta:** lamiera stirata spess. 3 mm, bordata spess. 8 mm. **Fissaggio:** in calce-truzzo, su pavimento solido o per collocamento libero.

**Ossature:** tube d'acier de Ø30 mm galvanisé à chaud. **Revêtement poudre polyester:** Coloris RAL au choix. **Assise:** en métal déployé - épaisseur 3 mm avec un rebord de 8 mm d'épaisseur. **Scellement:** Dans le sol, en surface ou autostable.

## contour

mod. 326M, 326MF



Peso | Gewicht | Poids | Weight: 40 kg

**Gestell:** Stahlrohr Ø30 mm feuerverzinkt. **Pulverbeschichtung:** RAL-Farben nach Wahl. **Sitzauflage:** Streckmetall 3 mm, mit U-Profil 8 mm gerändelt. **Befestigung:** zum Einbetonieren, zum Aufschrauben oder zum freien Aufstellen.

**Frame:** tubular steel frame Ø30 mm. **Powder coating:** RAL colour to choose. **Seating:** expanded metal thickness 3 mm, rounded-off edging thickness 8 mm. **Fixation:** fixed in the ground, surface mounting, free-standing.

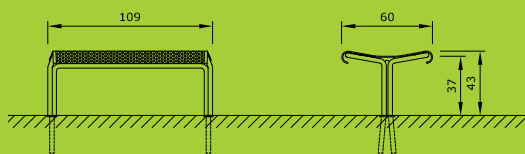

mod. 324M



mod. 324MF

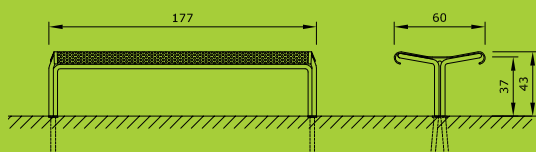

mod. 326M

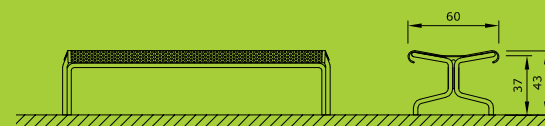

mod. 326MF

descrizione tecnica e disegni dwg | technische Beschreibung und dwg Zeichnungen | technical description and dwg drawings | description technique et dessins dwg: [www.euroform-w.com](http://www.euroform-w.com)





## contour

mod. 327M



Peso | Gewicht | Poids | Weight: 16 kg

## contour

mod. 328M



Peso | Gewicht | Poids | Weight: 30,5 kg

## contour

mod. 329M



Peso | Gewicht | Poids | Weight: 18 kg

## contour

mod. 330M



Peso | Gewicht | Poids | Weight: 27 kg

**Telaio:** tubo d'acciaio Ø30 mm zincato a fuoco. **Trattamento a polvere:** Colori RAL a scelta. **Seduta e schienale:** lamiera stirata spess. 3 mm, bordata spess. 8 mm. **Fissaggio:** in calcestruzzo, su pavimento solido o per collocamento libero.

**Ossature:** tube d'acier de Ø30 mm galvanisé à chaud. **Revêtement poudre polyester:** Coloris RAL au choix. **Assise et dossier:** en métal déployé - épaisseur 3 mm avec un rebord de 8 mm d'épaisseur. **Scellement:** Dans le sol, en surface ou autostable.

**Gestell:** Stahlrohr Ø30 mm feuerverzinkt. **Pulverbeschichtung:** RAL-Farben nach Wahl. **Sitzaufgabe und Rückenlehne:** Streckmetall 3 mm, mit U-Profil 8 mm gerändelt. **Befestigung:** zum Einbetonieren, zum Aufschrauben oder zum freien Aufstellen.

**Frame:** tubular steel frame Ø30 mm, hot-dip galvanized. **Powder coating:** RAL colour to choose. **Seating and Backrest:** expanded metal thickness 3 mm, rounded-off edging thickness 8 mm. **Fixation:** fixed in the ground, surface mounting, free-standing.

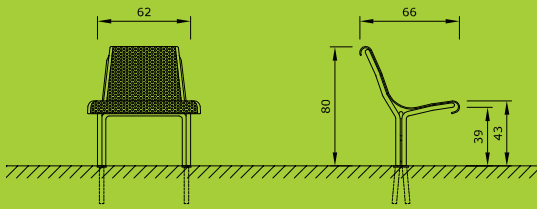

mod. 327M

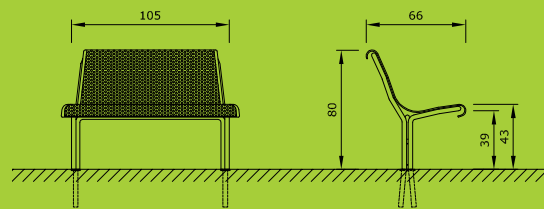

mod. 328M

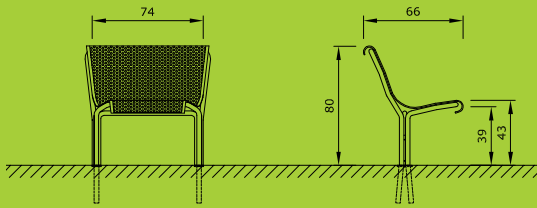

mod. 329M

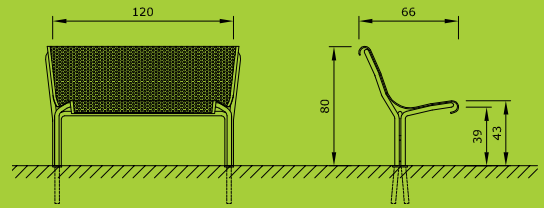

mod. 330M

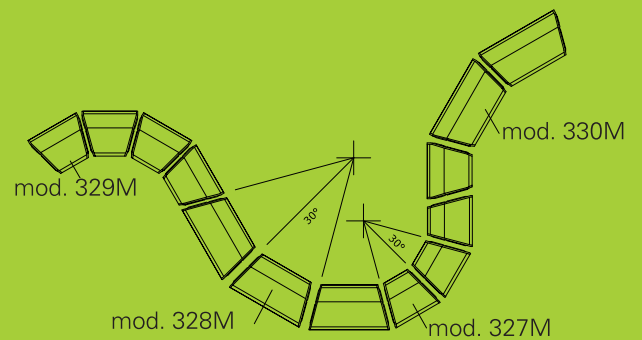
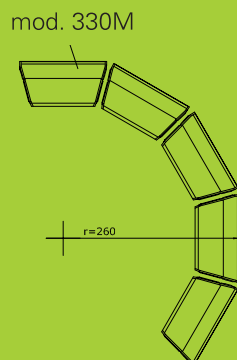
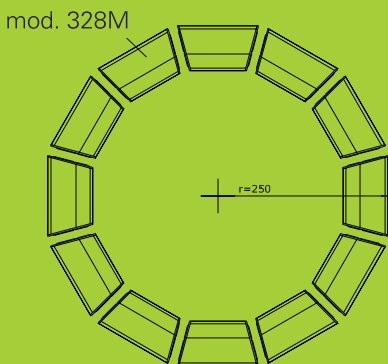
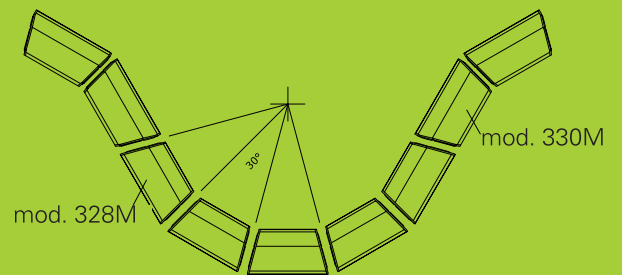
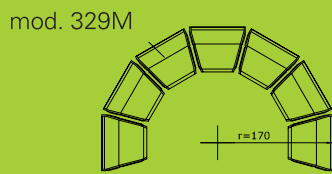
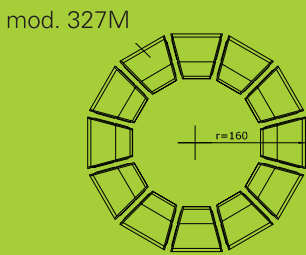
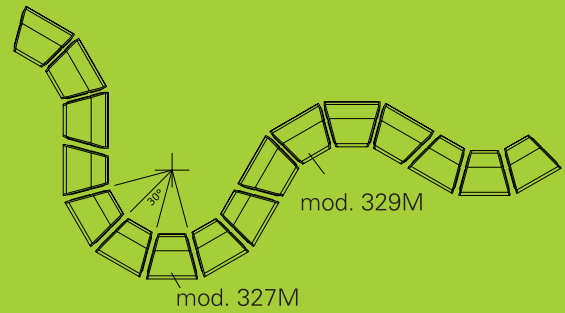
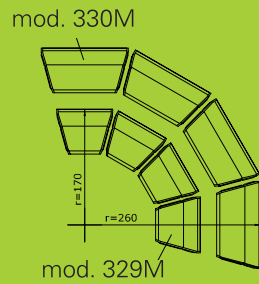
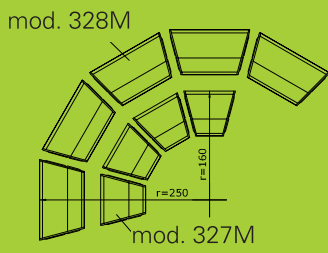

# contour

mod. 340M



Peso | Gewicht | Poids | Weight: 45 kg

**Telaio:** tubo d'acciaio Ø30 mm zincato a fuoco. **Trattamento a polvere:** Colori RAL a scelta. **Seduta e schienale:** lamiera stirata spess. 3 mm. **Fissaggio:** in calcestruzzo, su pavimento solido o per collocamento libero.

**Ossature:** tube d'acier de Ø30 mm galvanisé à chaud. **Revêtement poudre polyester:** Coloris RAL au choix. **Assise et dossier:** en métal déployé - épaisseur 3 mm. **Scellement:** Dans le sol, en surface ou autostable.

**Gestell:** Stahlrohr Ø30 mm feuerverzinkt. **Pulverbeschichtung:** RAL-Farben nach Wahl. **Sitzauflage und Rückenlehne:** Streckmetall 3 mm. **Befestigung:** zum Einbetonieren, zum Aufschrauben oder zum freien Aufstellen.

**Frame:** tubular steel frame Ø30 mm, hot-dip galvanized. **Powder coating:** RAL colour to choose. **Seating and Backrest:** expanded metal thickness 3 mm. **Fixation:** fixed in the ground, surface mounting, free-standing.

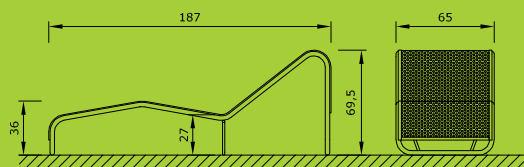

mod. 340M

descrizione tecnica e disegni dwg | technische Beschreibung und dwg Zeichnungen | technical description and dwg drawings | description technique et dessins dwg: [www.euroform-w.com](http://www.euroform-w.com)



# ambiente

mod. 53M, 54M, 55M



Peso | Gewicht | Poids | Weight: 30 kg | 40 kg | 52 kg

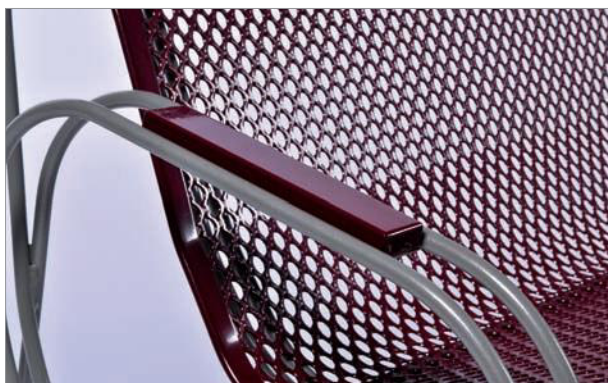

**Telaio:** tondino di ferro Ø12 mm zincato a fuoco. **Trattamento a polvere:** Colori RAL a scelta. **Seduta e schienale:** lamiera stirata spess. 3 mm, bordata spess. 8 mm. **Fissaggio:** in calcestruzzo, su pavimento solido o per collocamento libero.

**Ossature:** fer plein Ø12 mm galvanisé à chaud. **Revêtement poudre polyester:** Coloris RAL au choix. **Assise et dossier:** en métal déployé - épaisseur 3 mm avec un rebord de 8 mm d'épaisseur. **Scellement:** Dans le sol, en surface ou autostable.

**Gestell:** Rundeisen Ø12 mm feuerverzinkt. **Pulverbeschichtung:** RAL-Farben nach Wahl. **Sitzaufgabe und Rückenlehne:** Streckmetall 3 mm, mit U-Profil 8 mm gerändelt. **Befestigung:** zum Einbetonieren, zum Aufschrauben oder zum freien Aufstellen.

**Frame:** Ø12 mm rounded steel, hot-dip galvanized. **Powder coating:** RAL colour to choose. **Seating and Back-rest:** expanded metal thickness 3 mm, rounded-off edging thickness 8 mm. **Fixation:** fixed in the ground, surface mounting, free-standing.

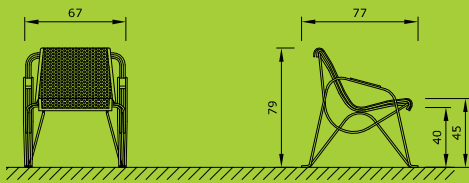

mod. 53M

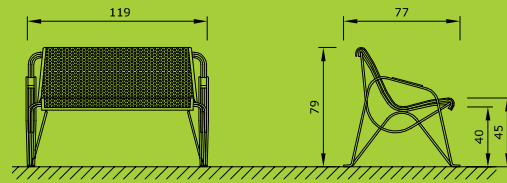

mod. 54M

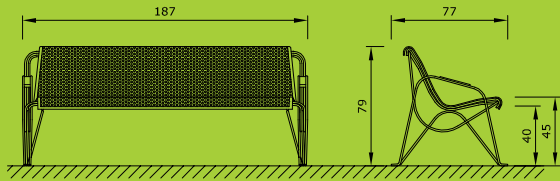

mod. 55M

descrizione tecnica e disegni dwg | technische Beschreibung und dwg Zeichnungen | technical description and dwg drawings | description technique et dessins dwg: [www.euroform-w.com](http://www.euroform-w.com)



## gala

mod. 58M



Peso | Gewicht | Poids | Weight: 50 kg

## gala

mod. 58M/10, 58M/20



Peso | Gewicht | Poids | Weight: 46 kg | 50 kg



mod. 58M/10, mod. 58M/20

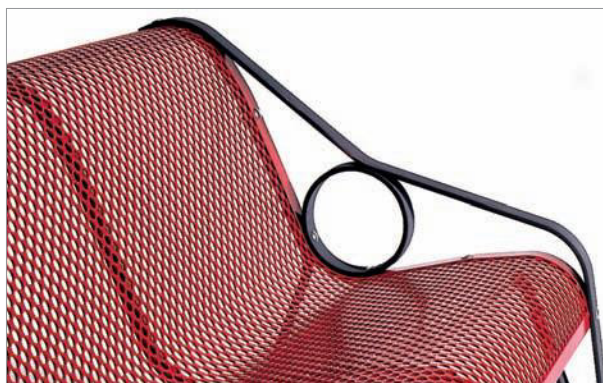

**Telaio:** ferro piatto 35x8 mm zincato. **Trattamento a polvere:** Colori RAL a scelta. **Seduta e schienale:** lamiera stirata spess. 3 mm, bordata spess. 8 mm. **Fissaggio:** in calcestruzzo, su pavimento solido o per collocamento libero.

**Ossature:** fer plat de 35x8 mm galvanisé. **Revêtement poudre polyester:** Coloris RAL au choix. **Assise et dossier:** en métal déployé - épaisseur 3 mm - avec un rebord de 8 mm d'épaisseur. **Scellement:** Dans le sol, en surface ou autostable.

**Gestell:** Flacheisen 35x8 mm verzinkt. **Pulverbeschichtung:** RAL-Farben nach Wahl. **Sitzauflage und Rückenlehne:** Streckmetall 3 mm, mit U-Profil 8 mm gerändelt. **Befestigung:** zum Einbetonieren, zum Aufschrauben oder zum freien Aufstellen.

**Frame:** flatbar frame 35x8 mm galvanized. **Powder coating:** RAL colour to choose. **Seating and back-rest:** expanded metal thickness 3 mm, rounded-off edging thickness 8 mm. **Fixation:** fixed in the ground, surface mounting, free-standing.



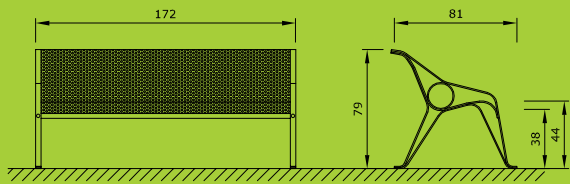

mod. 58M

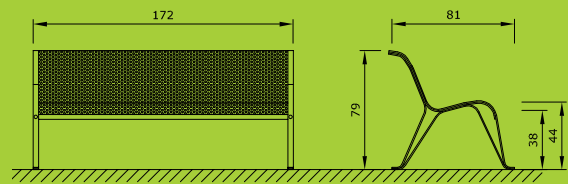

mod. 58M/10

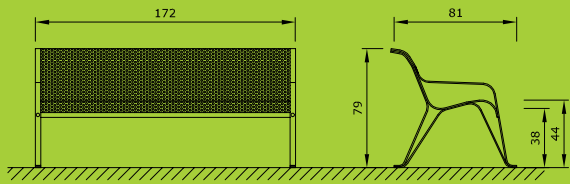

mod. 58M/20

descrizione tecnica e disegni dwg | technische Beschreibung und dwg Zeichnungen | technical description and dwg drawings | description technique et dessins dwg: [www.euroform-w.com](http://www.euroform-w.com)



Brunico, Italy



Park rail station, Bolzano, Italy

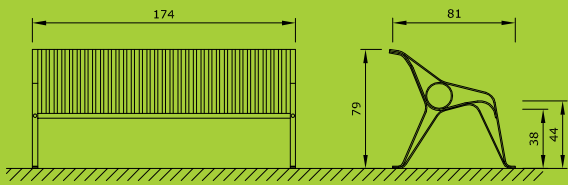

mod. 59M

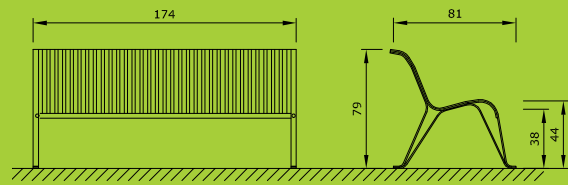

mod. 59M/10

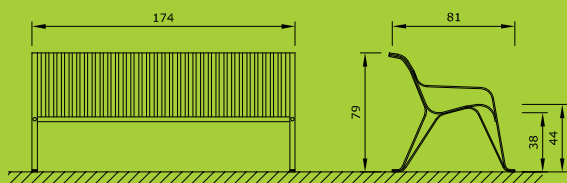

mod. 59M/20

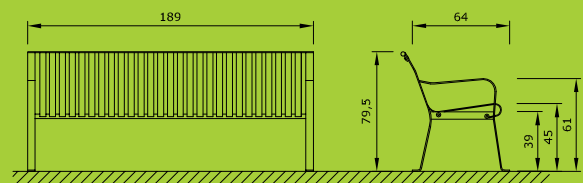

mod. 64M

descrizione tecnica e disegni dwg | technische Beschreibung und dwg Zeichnungen | technical description and dwg drawings | description technique et dessins dwg: [www.euroform-w.com](http://www.euroform-w.com)

## tulip

mod. 59M



Peso | Gewicht | Poids | Weight: 74 kg

## tulip

mod. 59M/20



Peso | Gewicht | Poids | Weight: 74 kg

## tulip

mod. 64M



Peso | Gewicht | Poids | Weight: 82 kg

**Telaio:** ferro piatto 35x8 mm zincato. **Trattamento a polvere:** Colori RAL a scelta. **Seduta e schienale:** ferri piatti 35x8 mm. **Fissaggio:** in calcestruzzo, su pavimento solido o per collocamento libero.

**Ossature:** fer plat de 35x8 mm galvanisé. **Revêtement poudre polyester:** Coloris RAL au choix. **Assise et dossier:** lames en fer plat 35x8 mm. **Scellement:** Dans le sol, en surface ou autostable.



mod. 59M/10

**Gestell:** Flacheisen 35x8 mm verzinkt. **Pulverbeschichtung:** RAL-Farben nach Wahl. **Sitzauflage und Rückenlehne:** Flacheisen 35x8 mm. **Befestigung:** zum Einbetonieren, zum Aufschrauben oder zum freien Aufstellen.

**Frame:** flatbar frame 35x8 mm galvanized. **Powder coating:** RAL colour to choose. **Seating and back-rest:** flat iron 30x5 mm. **Fixation:** fixed in the ground, surface mounting, free-standing.

## domino

mod. 70M/1



## domino

mod. 70M/3



## domino

mod. 70M/1 F



## domino

mod. 70M/4



**Telaio:** ferro piatto 60x6 mm o tubolare d'acciaio Ø60 mm.  
**Traverse:** tubolare quadrato 70 mm con giunto speciale.  
**Seduta e schienale:** lamiera stirata spess. 3 mm, bordata spess. 8 mm. **Trattamento a polvere:** Colori RAL a scelta.  
**Fissaggio:** in calcestruzzo, su pavimento solido o per collocamento libero.

**Ossature:** fer plat de 60x6 mm ou tube d'acier de Ø60 mm. **Traverses:** tube carré 70 mm avec rebord de 8 mm d'épaisseur. **Assise et dossier:** métal déployé 3 mm galvanisé à chaud. **Revêtement poudre polyester:** Coloris RAL au choix. **Scellement:** Dans le sol, en surface ou autostable.

**Gestell:** Flacheisen 60x 6 mm oder Stahlrohr Ø60 mm feuerverzinkt. **Traversen:** Quadratrohr 70 mm mit Spezialgelenk. **Sitzaufgabe und Rückenlehne:** Streckmetall 3 mm, mit U-Profil 8 mm gerändelt. **Pulverbeschichtung:** RAL-Farben nach Wahl. **Befestigung:** zum Einbetonieren, zum Aufschrauben oder zum freien Aufstellen.

**Frame:** flat iron 60x6 mm or tubular steel Ø60 mm. **Traverse:** made from hollow section 70 mm with special hinging. **Seating and back-rest:** expanded metal thickness 3 mm, rounded-off edging thickness 8 mm. **Powder coating:** RAL colour to choose. **Fixation:** fixed in the ground, surface mounting, free-standing.



mod. 70M/1



mod. 70M/7



mod. 70M/2



mod. 70M/8



mod. 70M/3



mod. 70M/9



snodo | Gelenk | élément articulé  
hinge section - mod. 70M/14



mod. 70M/4



mod. 70M/10



mod. 70M/5



mod. 70M/11



mod. 70M/6



mod. 70M/12



mod. 70M/13

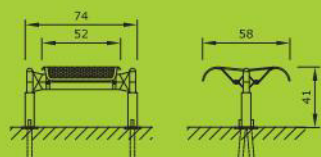

fisso | fest | fixe | fix

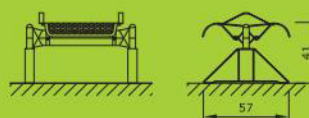

libero | freistehend | autostabile | free-standing

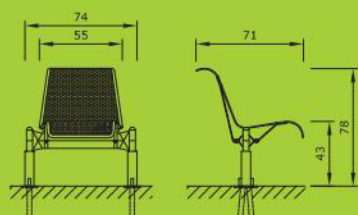

fisso | fest | fixe | fix

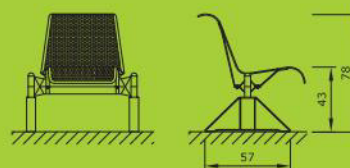

libero | freistehend | autostabile | free-standing

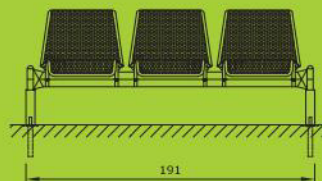
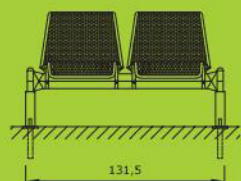

## economy

mod. 71M



## economy

mod. 71M/F



a muro | mauermontage  
fixation sur muret | plinth mounted

**Telaio:** tubo quadro 70 mm zincato a fuoco. **Seduta e schienale:** lamiera decapata forata spess. 2 mm bordata con tubo d'acciaio Ø30 mm. **Trattamento a polvere:** Colori RAL a scelta. **Fissaggio:** in calcestruzzo, su pavimento solido o per collocamento libero.

**Ossature:** tubecarré 70 mm, galvanisé à chaud. **Assise et dossier:** en tôle perforée 2 mm - avec rebord en tube d'acier Ø30 mm. **Revêtement poudre polyester:** Coloris RAL au choix. **Scellement:** Dans le sol, en surface ou auto-stable.

a parete | wandmontage  
fixation murale | wall mounted

**Gestell:** Quadratrohr 70 mm feuerverzinkt. **Sitzaufgabe und Rückenlehne:** Lochblech 2 mm, mit Stahlrohr Ø30 mm umrahmt. **Pulverbeschichtung:** RAL-Farben nach Wahl. **Befestigung:** zum Einbetonieren, zum Aufschrauben oder zum freien Aufstellen.

**Frame:** made from hollow section 70 mm, hot-dip galvanized. **Seating and back-rest:** perforated metal 2 mm and tubular steel Ø30 mm. **Powder coating:** RAL colour to choose. **Fixation:** fixed in the ground, surface mounting, free-standing.



mod. 71M/1



mod. 71M/4



mod. 71M/2



mod. 71M/5



mod. 71M/9



mod. 71M/6



mod. 71M/10



mod. 71M/7



mod. 71M/5



mod. 71M/8



mod. 71M/3

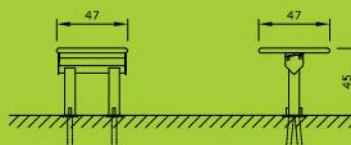
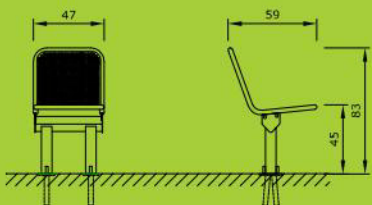
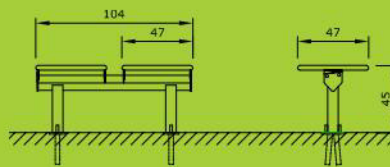
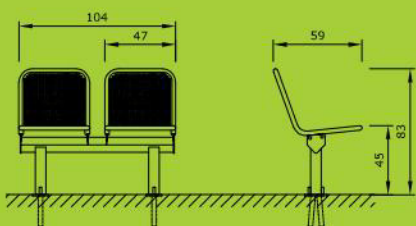
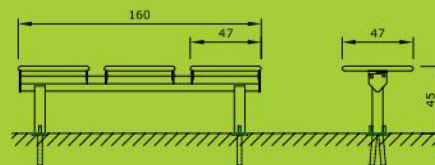
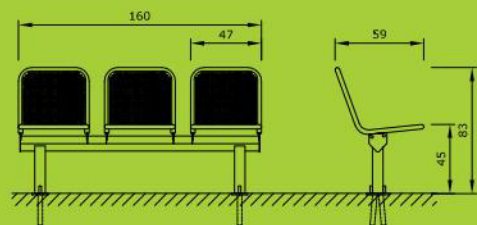

descrizione tecnica e disegni dwg | technische Beschreibung und dwg Zeichnungen | technical description and dwg drawings | description technique et dessins dwg: [www.euroform-w.com](http://www.euroform-w.com)

# fun bank

mod. 600

for  
kids



Peso | Gewicht | Poids | Weight: 18 kg

**Telaio:** tubo d'acciaio Ø30 mm zincato a fuoco. **Trattamento a polvere:** Colori RAL a scelta. **Fissaggio:** in calcestruzzo, su pavimento solido.

**Ossature:** tube d'acier de Ø30 mm galvanisé à chaud. **Revêtement poudre polyester:** Coloris RAL au choix. **Scellement:** Dans le sol, en surface.

**Gestell:** Stahlrohr Ø30 mm feuerverzinkt. **Pulverbeschichtung:** RAL-Farben nach Wahl. **Befestigung:** zum Einbetonieren, zum Aufschrauben.

**Frame:** tubular steel frame Ø30 mm, hot-dip galvanized. **Powder coating:** RAL colour to choose. **Fixation:** fixed in the ground, surface mounting.

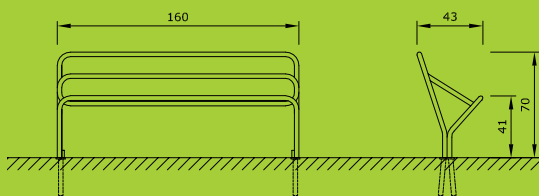

mod. 600

descrizione tecnica e disegni dwg | technische Beschreibung und dwg Zeichnungen | technical description and dwg drawings | description technique et dessins dwg: [www.euroform-w.com](http://www.euroform-w.com)





## cadira

mod. 1960



Peso | Gewicht | Poids | Weight: 11 kg

**Telaio:** tubo tondo Ø25 mm, zincato. **Seduta e schienale:** lamiera d'acciaio spess. 2 mm, zincato. **Poggiabraccia:** tubo tondo Ø25 mm, zincato. **Trattamento a polvere:** Colori RAL a scelta. **Fissaggio:** in calcestruzzo, su pavimento solido o per collocamento libero.

**Ossature:** tube ronde de Ø25 mm galvanisé. **Assise et dossier:** fer plat 2 mm, galvanisé. **Accoudoirs:** tube ronde Ø25 mm, galvanisé. **Revêtement poudre polyester:** Coloris RAL au choix. **Scellement:** Dans le sol, en surface ou autostable.

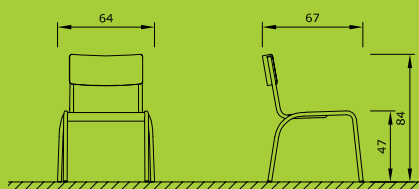

mod. 1960

## cadira

mod. 1962



Peso | Gewicht | Poids | Weight: 12 kg

**Gestell:** Rundrohr Ø25x2 mm, verzinkt. **Sitzauflage und Rückenlehne:** Stahlblech 2 mm, verzinkt. **Armlehne:** Rundrohr Ø25x2 mm, verzinkt. **Pulverbeschichtung:** RAL-Farben nach Wahl. **Befestigung:** zum Einbetonieren, zum Aufschrauben oder zum freien Aufstellen.

**Frame:** tubular steel Ø25 mm, galvanized. **Seating and back-rest:** steel sheet 2 mm, galvanized. **Armrests:** tubular steel Ø25 mm, galvanized. **Powder coating:** RAL colour to choose. **Fixation:** fixed in the ground, surface mounting, free-standing.

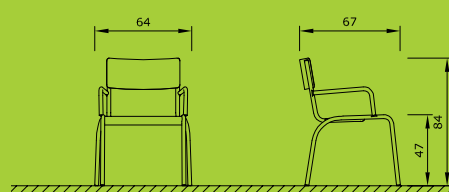

mod. 1962



## evol

mod. 4500



Peso | Gewicht | Poids | Weight: 62 kg

## clip

mod. 4512M



Peso | Gewicht | Poids | Weight: 94 kg

## clip

mod. 4515M



Peso | Gewicht | Poids | Weight: 175 kg

**EVOL/CLIP: Telaio:** lamiera d'acciaio spessore 10 mm, zincato a fuoco. **CRYOU: Telaio:** lamiera d'acciaio spessore 6 mm, zincato a fuoco. **Trattamento a polvere:** Colori RAL a scelta. **Fissaggio:** in calcestruzzo, su pavimento solido o per collocamento libero.

**EVOL/CLIP: Ossature:** fer plat 10 mm, galvanisé à chaud. **CRYOU: Ossature:** fer plat 6 mm, galvanisé à chaud. **Revêtement poudre polyester:** Coloris RAL au choix. **Scellement:** Dans le sol, en surface ou autostable.

## cryou

mod. 4520M, 4525M



Peso | Gewicht | Poids | Weight: 43 kg | 51 kg

**EVOL/CLIP: Gestell:** Stahlblech 10 mm, feuerverzinkt. **CRYOU: Gestell:** Stahlblech 6 mm, feuerverzinkt. **Pulverbeschichtung:** RAL-Farben nach Wahl. **Befestigung:** zum Einbetonieren, zum Aufschrauben oder zum freien Aufstellen.

**EVOL/CLIP: Frame:** steel sheet 10 mm, hot-dip galvanized. **CRYOU: Frame:** steel sheet 6 mm, hot-dip galvanized. **Powder coating:** RAL colour to choose. **Fixation:** fixed in the ground, surface mounting, free-standing.

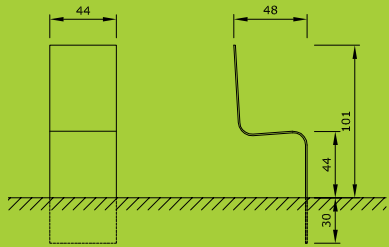

mod. 4500

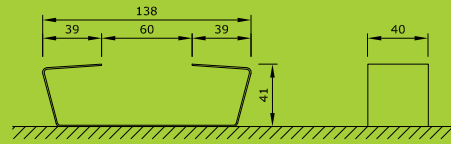

mod. 4512M

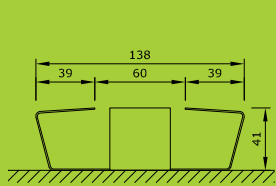

mod. 4515M

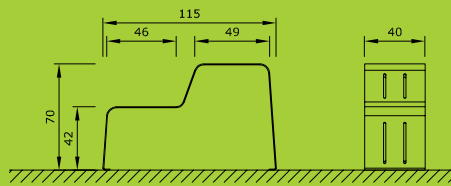

mod. 4520M

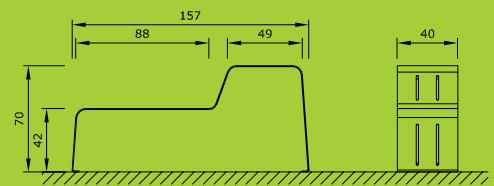

mod. 4525M

descrizione tecnica e disegni dwg | technische Beschreibung und dwg Zeichnungen | technical description and dwg drawings | description technique et dessins dwg: [www.euroform-w.com](http://www.euroform-w.com)



Place Roma, Venice, Italy

## free bench

mod. 4600



### FREE BENCH:

**Telaio:** tubo d'acciaio e ferro piatto, zincato a fuoco.

**Seduta:** lamiera stirata spess. 3 mm, bordata spess. 8 mm, zincato a fuoco.

### INFO POINT:

**Telaio:** in lamiera d'acciaio spess. 10 mm, zincato a fuoco.

**Trattamento a polvere:** Colori RAL a scelta. **Fissaggio:** in calcestruzzo, su pavimento solido.

### FREE BENCH:

**Ossature:** tube d'acier et fer plat, galvanisé à chaud. **Assise:** en métal déployé - épaisseur 3 mm avec un rebord de 8 mm d'épaisseur.

### INFO POINT:

**Ossature:** metal sheet 10 mm galvanisé à chaud. **Revêtement poudre polyester:** Coloris RAL au choix. **Scellement:** Dans le sol, en surface ou autostable.

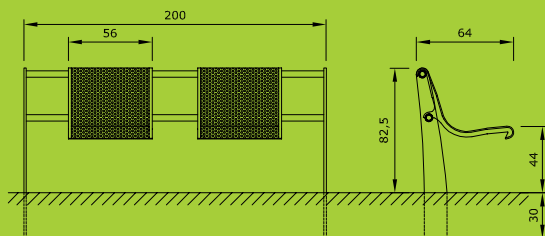

mod. 4600

## info point

mod. 4400, 4405



Peso | Gewicht | Poids | Weight: 30 kg | 79 kg

### FREE BENCH:

**Gestell:** Stahlrohr und Flacheisen, feuerverzinkt. **Sitzauflage:** Streckmetall 3 mm, mit U-Profil 8 mm, gerändelt, feuerverzinkt.

### INFO POINT:

**Gestell:** Stahlblech 10 mm, feuerverzinkt. **Pulverbeschichtung:** RAL-Farben nach Wahl. **Befestigung:** zum Einbetonieren, zum Aufschrauben.

### FREE BENCH:

**Frame:** steel tube and flat bar, hot-dip galvanized. **Seating:** expanded metal thickness 3 mm, rounded-off edging thickness 8 mm, hot-dip galvanized.

### INFO POINT:

**Frame:** hot-dip galvanized steel plat, 10 mm thick. **Powder coating:** RAL colour to choose. **Fixation:** fixed in the ground, surface mounting.

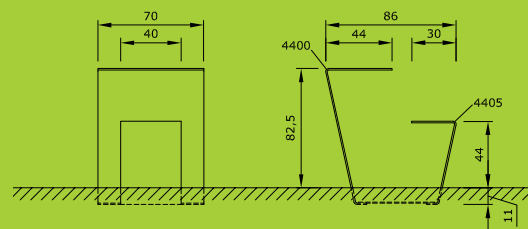

mod. 4400, 4405

descrizione tecnica e disegni dwg | technische Beschreibung und dwg Zeichnungen | technical description and dwg drawings | description technique et dessins dwg: [www.euroform-w.com](http://www.euroform-w.com)

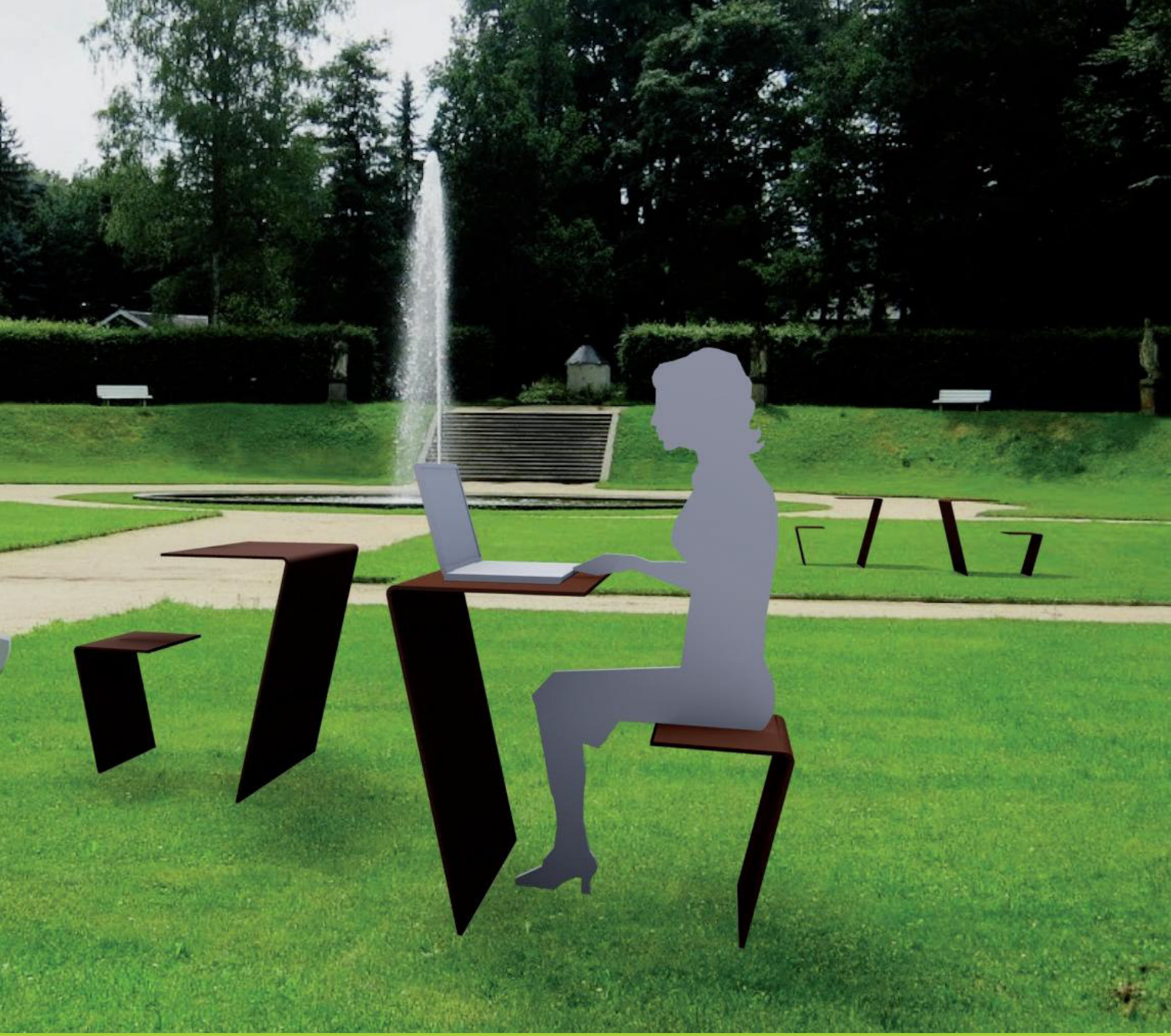

## acciaio inox | edelstahl | inox | stainless steel

euroform w offre tutta una serie di prodotti, ad esempio la panca Contour, anche nella versione in acciaio inox. Queste nobili e piacevoli soluzioni anche in combinazione con il legno sottolineano l'eleganza degli spazi pubblici.

euroform w bietet viele Produkte – z.B. die Parkbank Contour – in Edelstahlausführung an. Diese edel anmutenden Lösungen – auch in der Kombination mit Holz – unterstreichen die Eleganz öffentlicher Räume. Edelstahl hat daneben den Vorteil einer unbegrenzten Lebensdauer.

euroform w propose un grand nombre de produits dans la version inox (ex.: les bancs Contour). Ces solutions „nobles“ avec la possibilité de combiner bois et inox – apportent une touche élégante et originale au cadre de vie. En outre, l'acier inoxydable offre une durée de vie exceptionnelle au mobilier urbain.

euroform w offers many products in stainless steel variations – e.g. the Contour park bench. This fine solution – which works well combined with wood – underlines the elegance of public spaces. Stainless steel also has the advantage of an unlimited lifespan.







Capraia e Limite, Firenze, Italy





# tables

tavoli | tische | table

Una tavolo deve invitare a soffermarsi, per mangiare, per giocare o stare insieme. Euroform w offre quindi diversi tipi di tavoli, che si differenziano non solo per le dimensioni ma anche per la funzionalità. Non solo il materiale, ma anche la panca o la sedia adatta possono essere abbinati al tavolo.

Ein Tisch soll zum Verweilen, zum Essen, zum gemeinsamen Spiel oder zur Kommunikation einladen. Deshalb bietet euroform w unterschiedliche Arten von Tischen an, welche sich nicht nur von der Grösse, sondern auch von der Funktionalität unterscheiden. Nicht nur das Material, sondern auch die passende Bank oder der Stuhl können an den Tisch angepasst werden.

Une table doit inviter à s'arrêter, pour manger, pour jouer ensemble ou pour la communication. Euroform w offre différents types de tables qui se distinguent non seulement par leurs dimensions mais aussi par leur fonctionnalité. On peut associer à chaque table non seulement le matériel mais également le banc ou le siège adaptés.

A table should invite to linger, to eat, to play or for communication. Therefore euroform w offers different types of tables, which differ not only on the size but also on the functionality. Not only the material, but also the right bench or chair can be adjusted to the table.

## lineatavolo

mod. 870



Peso | Gewicht | Poids | Weight: 88 kg

**Telaio:** ferro piatto 15x60 mm (light: 10x60 mm) zincato.  
**Trattamento a polvere:** Colori RAL a scelta. **Seduta:** legno duro non trattato o trattato. **Fissaggio:** in calcestruzzo, su pavimento solido o per collocamento libero.

**Ossature:** Fer plat 15x60 mm (light: 10x60 mm), galvanisé. **Revêtement poudre polyester:** Coloris RAL au choix. **Assise:** Lattes en bois exotique sans traitement ou avec traitement de surface. **Scellement:** Dans le sol, en surface ou autostable.

## lineatavolo light

mod. 870L



Peso | Gewicht | Poids | Weight: 71 kg

**Gestell:** Flacheisen 15x60 mm (light: 10x60 mm), verzinkt.  
**Sitzauflage:** Hartholzbohlen unbehandelt oder behandelt.  
**Pulverbeschichtung:** RAL-Farben nach Wahl. **Befestigung:** zum Einbetonieren, zum Aufschrauben oder zum freien Aufstellen.

**Frame:** flat bar 15x60 mm (light: 10x60 mm), galvanized.  
**Powder coating:** RAL colour to choose. **Seating:** hard wooden slats untreated or treated. **Fixation:** fixed in the ground, surface mounting, free-standing.

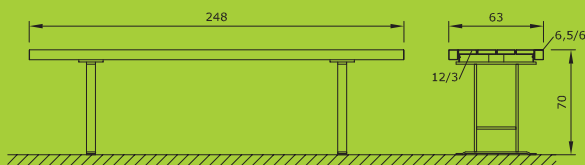

mod. 870

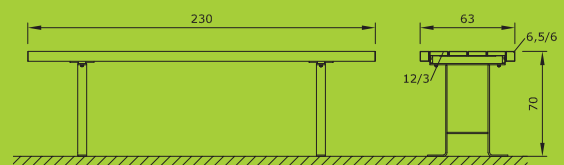

mod. 870L

descrizione tecnica e disegni dwg | technische Beschreibung und dwg Zeichnungen | technical description and dwg drawings | description technique et dessins dwg: [www.euroform-w.com](http://www.euroform-w.com)





Centre Nautique Saint Maurice de Beynost, France

## zeta pic-nic

mod. 1400, 1410



Peso | Gewicht | Poids | Weight: 36 kg | 54 kg

**Telaio:** ferro piatto 8x80 mm e 10x80 mm, zincato. **Trattamento a polvere:** Colori RAL a scelta. **Seduta:** legno duro non trattato o trattato. **Fissaggio:** in calcestruzzo, su pavimento solido o per collocamento libero.

**Ossature:** Fer plat 8x80 mm et 10x80 mm, galvanisé. **Revêtement poudre polyester:** Coloris RAL au choix. **Assise:** Lattes en bois exotique sans traitement ou avec traitement de surface. **Scellement:** Dans le sol, en surface ou autostable.

## zeta pic-nic

mod. 1430, 1435



Peso | Gewicht | Poids | Weight: 17 kg | 42 kg

**Gestell:** Flacheisen 8x80 mm und 10x80 mm, verzinkt. **Sitzaufgabe:** Hartholzbohlen unbehandelt oder behandelt. **Pulverbeschichtung:** RAL-Farben nach Wahl. **Befestigung:** zum Einbetonieren, zum Aufschrauben oder zum freien Aufstellen.

**Frame:** flat bar 8x80 mm and 10x80 mm, galvanized. **Power coating:** RAL colour to choose. **Seating:** hard wooden slats untreated or treated. **Fixation:** fixed in the ground, surface mounting, free-standing.

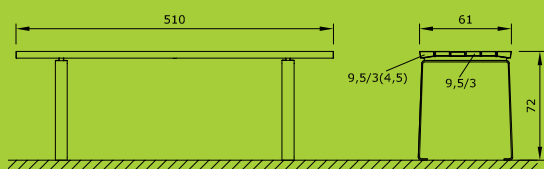

mod. 1410

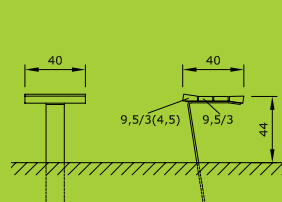

mod. 1430

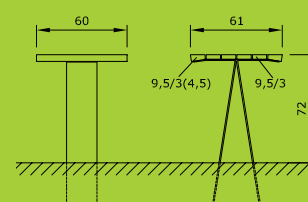

mod. 1435

descrizione tecnica e disegni dwg | technische Beschreibung und dwg Zeichnungen | technical description and dwg drawings | description technique et dessins dwg: [www.euroform-w.com](http://www.euroform-w.com)





Park Orzali, Monsummano Terme, Pistoia, Italy



## alltable

mod. 1030



Peso | Gewicht | Poids | Weight: 68 kg

**ALLTABLE: Telaio:** lamiera d'acciaio zincata, spess. 6 mm. Rinforzo orizzontale tubo mobilio da Ø42 mm. **Seduta:** legno duro non trattato o trattato. **ING:** tubo rettangolare 150x40 mm zincato a fuoco. lamiera d'acciaio 6 mm. **Trattamento a polvere:** Colori RAL a scelta. **Fissaggio:** in calcestruzzo, su pavimento solido o per collocamento libero.

**ALLTABLE: Ossature:** fer plat 6 mm galvanisé. Barre transversale en tube rond Ø42 mm. **Assise:** Lattes en bois exotique sans traitement ou avec traitement de surface. **ING:** tube rectangulaire 150x40 mm galvanisé à chaud. Fer plat 6 mm. **Revêtement poudre polyester:** Coloris RAL au choix. **Scellement:** Dans le sol, en surface ou autostable.

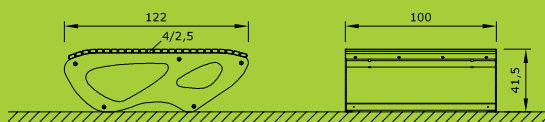

mod. 1030

## ing

mod. 1650



Peso | Gewicht | Poids | Weight: 29 kg

**ALLTABLE: Gestell:** Stahlblech 6 mm, verzinkt. Querverstrebung aus Rundrohr Ø42 mm. **Sitzauflage:** Hartholzbohlen unbehandelt oder behandelt. **ING:** Rechteckrohr 150x40 mm, feuerverzinkt. Stahlblech 6 mm. **Pulverbeschichtung:** RAL-Farben nach Wahl. **Befestigung:** zum Einbetonieren, zum Aufschrauben oder zum freien Aufstellen.

**ALLTABLE: Frame:** 6 mm sheet steel, galvanized. Horizontal reinforcement with round section pipe, Ø42 mm. **Seating:** hard wooden slats untreated or treated. **ING:** square tube 150x40 mm, hot-dip galvanized. Sheet steel 6 mm. **Powder coating:** RAL colour to choose. **Fixation:** fixed in the ground, surface mounting, free-standing.

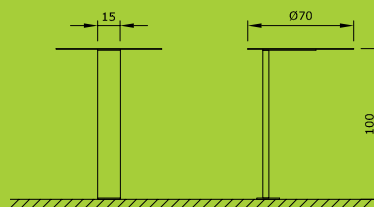

mod. 1650

descrizione tecnica e disegni dwg | technische Beschreibung und dwg Zeichnungen | technical description and dwg drawings | description technique et dessins dwg: [www.euroform-w.com](http://www.euroform-w.com)







Libourne, Oceano Verde, France



## contour

mod. 324T



Peso | Gewicht | Poids | Weight: 28 kg

## contour

mod. 326T



Peso | Gewicht | Poids | Weight: 47 kg

## contour

mod. 324M/T



Peso | Gewicht | Poids | Weight: 28 kg

## contour

mod. 326M/T



Peso | Gewicht | Poids | Weight: 47 kg

**Telaio:** tubo d'acciaio Ø30 mm zincato a fuoco. **Trattamento a polvere:** Colori RAL a scelta. **Seduta:** legno duro non trattato o trattato. o lamiera stirata spess. 3 mm, bordata spess. 8 mm. **Fissaggio:** in calcestruzzo, su pavimento solido o per collocamento libero.

**Ossature:** tube d'acier Ø30 mm galvanisé à chaud. **Revêtement poudre polyester:** Coloris RAL au choix. **Assise:** Lattes en bois exotique sans traitement ou avec traitement de surface. o en métal déployé - épaisseur 3 mm avec un rebord de 8 mm d'épaisseur. **Scellement:** ans le sol, en surface ou autostable.

**Gestell:** Stahlrohr Ø30 mm feuerverzinkt. **Sitzauflage:** Hartholzbohlen unbehandelt oder behandelt. oder Streckmetall 3 mm, mit U-Profil 8 mm gerändelt. **Pulverbeschichtung:** RAL-Farben nach Wahl. **Befestigung:** zum Einbetonieren, zum Aufschrauben oder zum freien Aufstellen.

**Frame:** tubular steel Ø30 mm, hot-dip galvanized. **Powder coating:** RAL colour to choose. **Seating:** hard wooden slats untreated or treated. o expanded metal thickness 3 mm, rounded-off edging thickness 8 mm. **Fixation:** fixed in the ground, surface mounting, free-standing.

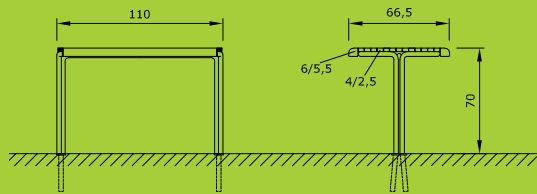

mod. 324T

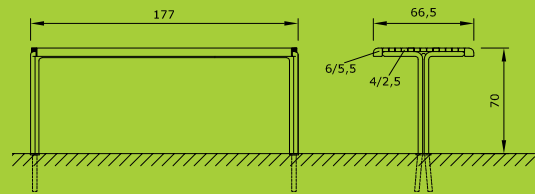

mod. 326T

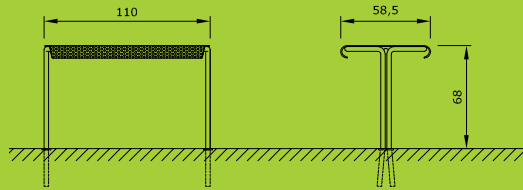

mod. 324M/T

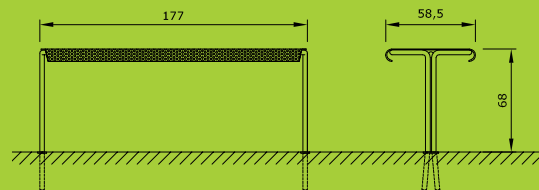

mod. 326M/T

descrizione tecnica e disegni dwg | technische Beschreibung und dwg Zeichnungen | technical description and dwg drawings | description technique et dessins dwg: [www.euroform-w.com](http://www.euroform-w.com)



Campo Marte, Crema, Cremona, Italy



Bern, Bümpliz, Switzerland

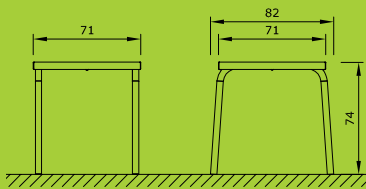

mod. 1970

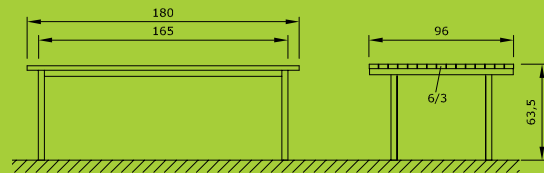

mod. 885

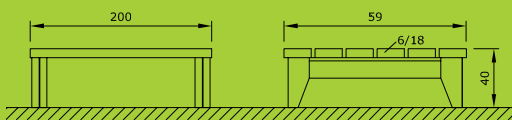

mod. 90T

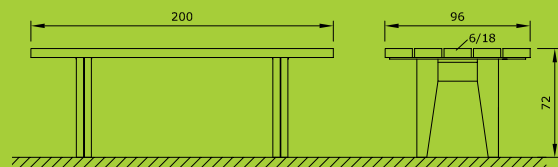

mod. 90T-1  
Peso | Gewicht | Poids | Weight: 120 kg

descrizione tecnica e disegni dwg | technische Beschreibung und dwg Zeichnungen | technical description and dwg drawings | description technique et dessins dwg: [www.euroform-w.com](http://www.euroform-w.com)



## mesa

mod. 1970



Peso | Gewicht | Poids | Weight: 19 kg

## quattro

mod. 885



Peso | Gewicht | Poids | Weight: 65 kg

## block

mod. 90T



Peso | Gewicht | Poids | Weight: 90 kg

**MESA: Telaio:** tubo tondo Ø42 mm, zincato. **Ripiano tavolo:** lamiera d'acciaio 1,5 mm, zincato.  
**QUATTRO: Telaio:** tubo quadro d'acciaio 40 mm zincato a fuoco. **Ripiano tavolo:** legno duro non trattato o trattato.  
**BLOCK: Telaio:** lamiera decapata e stampata da 2 mm zincata a fuoco. **Ripiano tavolo:** legno duro non trattato o trattato. **Trattamento a polvere:** Colori RAL a scelta. **Fissaggio:** in calcestruzzo, su pavimento solido o per colloca-mento libero.

**MESA: Ossature:** tube ronde Ø42 mm galvanisé à chaud. **Table:** acier 1,5 mm galvanisé.

**QUATTRO: Ossature:** tube d'acier 40 mm galvanisé à chaud. **Table:** Lattes en bois exotique sans traitement ou avec traitement. **BLOCK: Ossature:** acier 2 mm galvanisé à chaud. **Table:** Lattes en bois exotique sans traitement ou avec traitement de surface. **Revêtement poudre polyester:** Coloris RAL au choix. **Scellement:** Dans le sol, en surface ou autostable.



mod. 90T-1

**MESA: Gestell:** Rundrohr Ø42 mm verzinkt. **Tischplatte:** verzinktes Stahlblech 1,5 mm.

**QUATTRO: Gestell:** Quadratrohr 40 mm feuerverzinkt. **Tischplatte:** Hartholzbohlen unbehandelt oder behandelt.  
**BLOCK: Gestell:** Stahlblech 2 mm feuerverzinkt. **Tischplatte:** Hartholzbohlen unbehandelt oder behandelt. **Pulverbeschichtung:** RAL-Farben nach Wahl. **Befestigung:** zum Einbetonieren, zum Aufschrauben oder zum freien Aufstellen.

**MESA: Frame:** tubular steel Ø42 mm galvanized. **Table:** galvanized metal sheet 1,5 mm.

**QUATTRO: Frame:** square steel 40 mm, hot-dip galvanized. **Table:** hard wooden slats untreated or treated.  
**BLOCK: Frame:** 2 mm sheet steel, hot-dip galvanized. **Table:** hard wooden slats untreated or treated. **Powder coating:** RAL colour to choose. **Fixation:** fixed in the ground, surface mounting, free-standing.

## mini pic-nic

mod. 315, 34

for  
kids



Peso | Gewicht | Poids | Weight: 19 kg | 17 kg

**MINI PIC-NIC: Panchina e tavolo: Telaio:** tubo d'acciaio Ø18 mm zincato a fuoco.

**VENUS MINI: Telaio:** tubo d'acciaio Ø30 mm, zincato a fuoco.

**Seduta e schienale:** listelli in legno duro non trattati. **Trattamento a polvere:** Colori RAL a scelta. **Fissaggio:** in calcestruzzo, su pavimento solido o per collocamento libero.

**MINI PIC-NIC: Banc et table: Ossature:** tube d'acier Ø18 mm galvanisé à chaud.

**VENUS MINI: Ossature:** tube d'acier Ø30 mm.

**Assise et dossier:** Lattes en bois exotique sans traitement ou avec traitement. **Revêtement poudre polyester:** Coloris RAL au choix. **Scellement:** Dans le sol, en surface ou auto-stable.

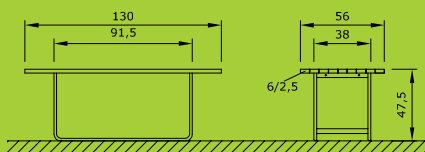

mod. 315

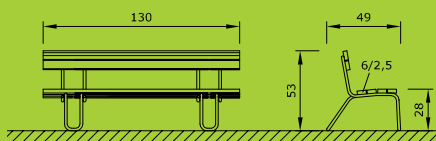

mod. 34

descrizione tecnica e disegni dwg | technische Beschreibung und dwg Zeichnungen | technical description and dwg drawings | description technique et dessins dwg: [www.euroform-w.com](http://www.euroform-w.com)

## venus mini

mod. 563

for  
kids



Peso | Gewicht | Poids | Weight: 48 kg

**MINI PIC-NIC: Bank und Tisch: Gestell:** Rundrohr Ø18 mm feuerverzinkt.

**VENUS MINI: Gestell:** Rundrohr Ø30 mm, feuerverzinkt.

**Sitzauflage und Rückenlehne:** Hartholzbohlen unlasiert.

**Pulverbeschichtung:** RAL-Farben nach Wahl. **Befestigung:** zum Einbetonieren, zum Aufschrauben oder zum freien Aufstellen.

**MINI PIC-NIC: Bench and table: Frame:** steel tube Ø18 mm, hot-dip galvanized.

**VENUS MINI: Frame:** steel tube Ø30 mm, hot-dip galvanized.

**Seating and back-rest:** hard wooden slats untreated or treated. **Powder coating:** RAL colour to choose. **Fixation:** fixed in the ground, surface mounting, free-standing.

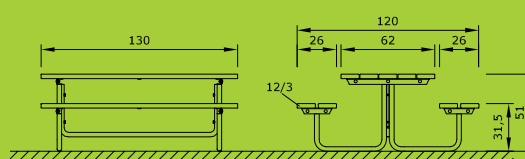

mod. 563

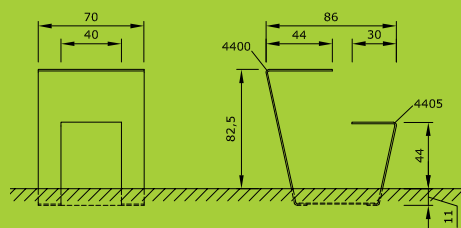

mod. 4400, 4405



# info point

mod. 4400, 4405

---



Peso | Gewicht | Poids | Weight: 30 kg | 79 kg

**INFO POINT: Telaio:** lamiera d'acciaio spess. 10 mm, zincato a fuoco. **Trattamento a polvere:** Colori RAL a scelta. **Fissaggio:** in calcestruzzo.

**INFO POINT: Ossature:** acier 10 mm, galvanisé à chaud. **Revêtement poudre polyester:** Coloris RAL au choix. **Scellement:** Dans le sol.

**INFO POINT: Gestell:** Stahlblech 10 mm, feuerverzinkt. **Pulverbeschichtung:** RAL-Farben nach Wahl. **Befestigung:** zum Einbetonieren.

**INFO POINT: Frame:** hot-dip galvanized steel plat, 10 mm thick. **Powder coating:** RAL colour to choose. **Fixation:** fixed in the ground.



Ecole les Dondaines, Lille, France

## mercurio

mod. 560



Peso | Gewicht | Poids | Weight: 120 kg

## venus

mod. 562



Peso | Gewicht | Poids | Weight: 112 kg

## pluto

mod. 571



Peso | Gewicht | Poids | Weight: 80 kg

**VENUS + PLUTO: Telaio:** tubo d'acciaio Ø42 mm zincato a fuoco. **MERCURIO: Telaio:** tubo d'acciaio Ø30 mm zincato a fuoco. **Seduta (mod. 560, 562):** legno duro non trattato o trattato. **Seduta (mod. 571):** lamiera stirata spess. 3 mm, bordata spess. 8 mm. **Trattamento a polvere:** Colori RAL a scelta. **Fissaggio:** in calcestruzzo, su pavimento solido o per collocamento libero.

**VENUS + PLUTO: Ossature:** tube d'acier Ø42 mm galvanisé à chaud. **MERCURIO: Ossature:** tube d'acier Ø30 mm galvanisé à chaud. **Assise (mod. 560, 562):** Lattes en bois exotique sans traitement ou avec traitement. **Assise (mod. 571):** en métal déployé - épaisseur 3 mm avec un rebord de 8 mm d'épaisseur. **Revêtement poudre polyester:** Coloris RAL au choix. **Scellement:** Dans le sol, en surface ou autostable.

**VENUS + PLUTO: Gestell:** Stahlrohr Ø42 mm feuerverzinkt. **MERCURIO: Gestell:** Stahlrohr Ø30 mm feuerverzinkt. **Sitzaufgabe (mod. 560, 562):** Hartholzbohlen unbehandelt oder behandelt. **Sitzaufgabe (mod. 571):** Streckmetall 3 mm, mit U-Profil 8 mm gerändelt. **Pulverbeschichtung:** RAL-Farben nach Wahl. **Befestigung:** zum Einbetonieren, zum Aufschrauben oder zum freien Aufstellen.

**VENUS + PLUTO: Frame:** tubular steel diam. 30 mm, hot-dip galvanized. **MERCURIO: Frame:** tubular steel diam. 30 mm, hot-dip galvanized. **Seating (mod. 560, 562):** hard wooden slats untreated or treated. **Seating (mod. 571):** expanded metal thickness 3 mm, rounded-off edging thickness 8 mm. **Powder coating:** RAL colour to choose. **Fixation:** fixed in the ground, surface mounting, free-standing.



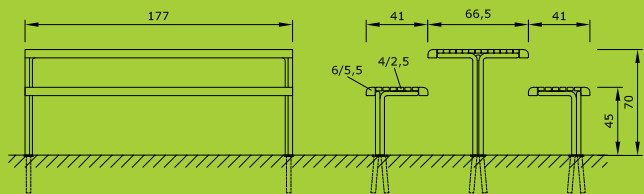

mod. 560

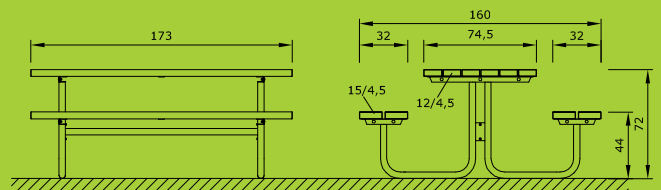

mod. 562

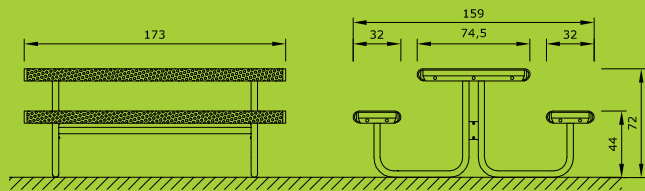

mod. 571

descrizione tecnica e disegni dwg | technische Beschreibung und dwg Zeichnungen | technical description and dwg drawings | description technique et dessins dwg: [www.euroform-w.com](http://www.euroform-w.com)



Subway, France





# litter bins

cestini portafiumi | Abfallbehälter | corbeilles

Forme pulite, praticità, igienicità, apertura facile, serratura auto-chiudente e semplice gestione dei rifiuti, caratterizzano i nostri contenitori per i rifiuti. Del nostro ricco assortimento di forme, materiali, diverse possibilità di fissaggio, troveremo sicuramente anche il contenitore per rifiuti adeguato per le Vostre esigenze!

Klare Formen, hygienisch und praktisch, einfache Öffnung und Handhabung durch ein selbstschließendes Absperrsystem zeichnen unsere Abfallbehälter aus. Aus unserem reichen Sortiment an verschiedene Formen, Materialien, Befestigungsmöglichkeiten finden Sie bestimmt auch den geeigneten Abfallbehälter für Ihre Zwecke!

Formes claires, hygiène et fonctionnalité, ouverture et gestion facile et un système à fermeture automatique simple caractérisent nos conteneurs pour déchets. Dans notre riche assortiment de formes, matériaux et différentes possibilités de fixation, nous trouverons sans doute aussi le conteneur pour déchets adapté à vos exigences!

Clear forms, hygienic and practical, easy opening and handling by a self-closing shut-down system characterize our litter bins. In our rich assortments of different shapes, materials, and fixation options, we are sure to find also the appropriate litter bin for your purposes!

## contour

mod. 275H, 275H/W, 276H, 276HA

---



Peso | Gewicht | Poids | Weight: 18 | 17 | 22 kg  
Capacità | Inhalt | Contenance | Capacity: 60 l | 60 l

## contour

mod. 276H/120

---



Peso | Gewicht | Poids | Weight: 37 kg  
Capacità | Inhalt | Contenance | Capacity: 120 l

## quattro

mod. 860, 860A

---



Peso | Gewicht | Poids | Weight: 40 kg  
Capacità | Inhalt | Contenance | Capacity: 50 l

## scala

mod. 2010

---



Peso | Gewicht | Poids | Weight: 35 kg  
Capacità | Inhalt | Contenance | Capacity: 60 l



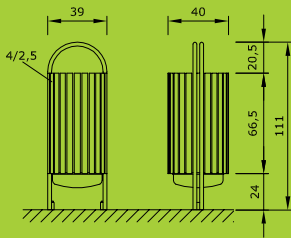

mod. 275H

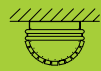
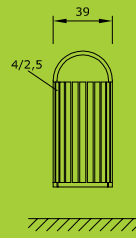

mod. 275H/W

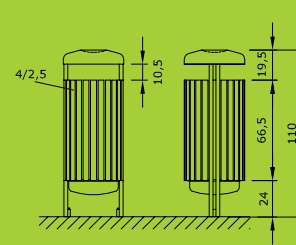
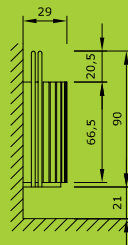

mod. 276H, 276HA

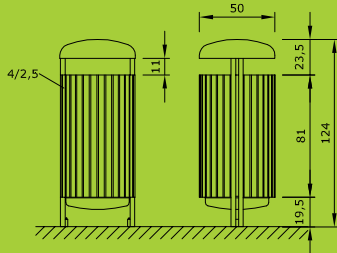

mod. 276H/120

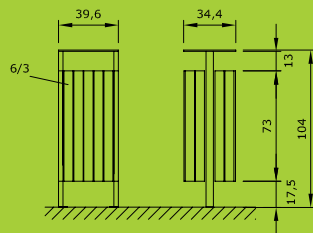

mod. 860

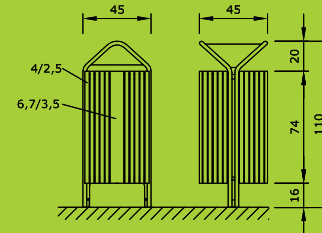

mod. 2010, 2010A

descrizione tecnica e disegni dwg | technische Beschreibung und dwg Zeichnungen | technical description and dwg drawings | description technique et dessins dwg: [www.euroform-w.com](http://www.euroform-w.com)



**CONTOUR: Telaio:** tubo d'acciaio Ø25 mm zincato a fuoco. **Coperchio:** metallo, fondo stampato spess. 2 mm. **Rivestimento:** listelli in legno duro non trattato o trattato. **QUATTRO: Telaio:** tubo rettangolare 50x30 mm zincato a fuoco. **Coperchio:** lamiera decapata spess. 8 mm. **Rivestimento:** listelli in legno duro, non trattato o trattato. **SCALA: Telaio:** tubo d'acciaio Ø 25 mm zincato a fuoco. **Coperchio:** metallo, lamiera decapata spess. 2 mm. **Rivestimento:** listelli in legno duro non trattato o trattato. **Serratura:** con chiave a triangolo, autochiudente. **Trattamento a polvere:** Colori RAL a scelta. **Fissaggio:** in calcestruzzo, su pavimento solido o collocamento libero con basamento in calcestruzzo.

**CONTOUR: Ossature:** tube d'acier Ø25 mm galvanisé à chaud. **Couvercle:** en acier - fond moulé épaisseur 2 mm. **Habillage:** lattes en bois exotique, sans traitement de surface ou avec traitement. **QUATTRO: Ossature:** tube d'acier 50x30 mm galvanisé à chaud. **Couvercle:** en acier - fond moulé épaisseur 2 mm. **Habillage:** lattes en bois exotique, sans traitement de surface ou avec traitement. **SCALA: Ossature:** en tube d'acier Ø 25 mm galvanisé à chaud. **Couvercle:** en acier - fond moulé épaisseur 2 mm. **Habillage:** lattes en bois exotique, sans traitement de surface ou avec traitement. **Verrouillage:** Avec clé triangulaire – fermeture automatique. **Revêtement poudre polyester:** Coloris RAL au choix. **Scellement:** Dans le sol, en surface ou autostable avec une base en béton.

**CONTOUR: Gestell:** Stahlrohr Ø25 mm feuerverzinkt. **Abdeckung:** Stahlblech-Presssteile 2mm. **Pulverbeschichtung:** RAL Farben nach Wahl. **Ummantelung:** Hartholzbohlen, unbehandelt. **QUATTRO: Gestell:** Stahlrohr 50x30 mm feuerverzinkt. **Abdeckung:** Stahlblech 8 mm. **Ummantelung:** Hartholzbohlen, unbehandelt oder behandelt. **SCALA: Gestell:** Stahlrohr Ø 25 mm feuerverzinkt. **Abdeckung:** Stahlblech-Presssteilen 2mm. **Ummantelung:** Hartholzbohlen behandelt oder unbehandelt. **Verriegelung:** mit Dreikantschlüssel, selbstschliessend. **Pulverbeschichtung:** RAL-Farben nach Wahl. **Befestigung:** zum Einbetonieren, zum Aufschrauben oder zum freien Aufstellen mit Betonsockel.

**CONTOUR: Frame:** tubular steel Ø25 mm. **Casing:** hard wood boards untreated or treated. **Cover:** from metal depth 2 mm. **QUATTRO: Frame:** metal tubing 50x30 mm. **Casing:** hard wood boards treated or untreated. **Cover:** from steel plat 8 mm. **SCALA: Frame:** tubular steel diam. 25 mm. **Powder coating:** RAL colour to choose. **Casing:** hard wood boards untreated or treated. **Cover:** from metal sheet 2 mm. **Closing:** triangular key, self-closing. **Powder coating:** RAL colour to choose. **Fixation:** fixed in the ground, surface mounting mounting, freestanding or with external concrete element.

## lineacestino

mod. 2040, 2050, 2050A



Peso | Gewicht | Poids | Weight: 36 kg | 45 kg  
Capacità | Inhalt | Contenance | Capacity: 50 l | 50 l

## lineacestino light

mod. 2040L, 2050L, 2050L/A



Peso | Gewicht | Poids | Weight: 26 kg | 32 kg  
Capacità | Inhalt | Contenance | Capacity: 50 l | 50 l

## allcan

mod. 1050, 1060



Peso | Gewicht | Poids | Weight: 40 | 50 kg  
Capacità | Inhalt | Contenance | Capacity: 60 l

**LINEA: Telaio:** ferro piatto 15x60 mm (light: 10x60 mm) zincato. **Rivestimento:** lamiera forata spess. 2 mm, fori 10x10 mm zincato.  
**ALLCAN: Telaio:** lamiera d'acciaio zincata spess. 6 mm. **Rivestimento:** in lamiera d'acciaio spess. 2,5 mm. **Serratura:** con chiave a triangolo, autochiudente. **Trattamento a polvere:** Colori RAL a scelta. **Fissaggio:** in calcestruzzo, su pavimento solido o per collocamento libero.

**LINEA: Ossature:** fer plat 15x60 mm (light: 10x60 mm), galvanisé. **Habillage:** Tôle perforée 2,5 mm - perforations 10x10 mm - galvanisé.

**ALLCAN: Ossature:** en acier galvanisé 6 mm. **Habillage:** en tôle d'acier galvanisé 2,5 mm. **Verrouillage:** Avec clé triangulaire – fermeture automatique. **Revêtement poudre polyester:** Coloris RAL au choix. **Scellement:** Dans le sol, en surface ou autostable.

**LINEA: Gestell:** Flacheisen 15x60 mm (light: 10x60 mm), verzinkt. **Ummantelung:** Lochblech 2,5 mm, Quadratlöcher 10x10 mm, verzinkt.

**ALLCAN: Gestell:** verzinktes Blech 6 mm. **Ummantelung:** aus verzinktem Blech 2,5 mm. **Verriegelung:** mit Dreikantschlüssel, selbstschliessend. **Pulverbeschichtung:** RAL-Farben nach Wahl. **Befestigung:** zum Einbetonieren, zum Aufschrauben oder zum freien Aufstellen.

**LINEA: Frame:** flat bar 15x60 mm (light: 10x60 mm), galvanized. **Panelling:** perforated metal sheet 2,5 mm, holes 10x10 mm, galvanized.

**ALLCAN: Frame:** 6 mm galvanized steel sheet. **Covering:** 2,5mm steel sheet. **Closing:** triangular key, self-closing. **Powder coating:** RAL colour to choose. **Fixation:** fixed in the ground, surface mounting, free-standing.

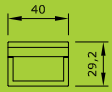
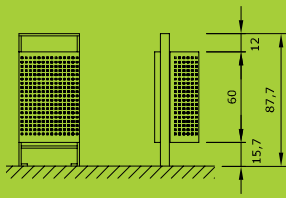

mod. 2040

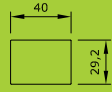
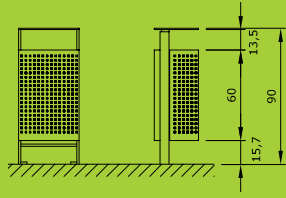

mod. 2050

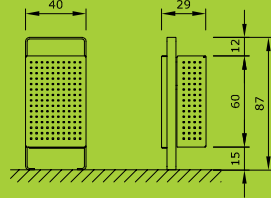

mod. 2040L

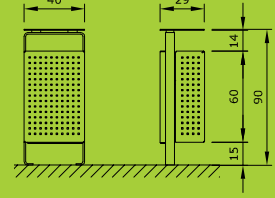

mod. 2050L

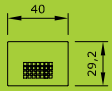
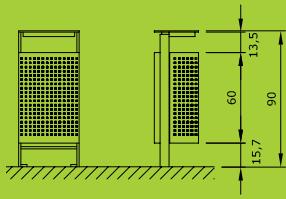

mod. 2050A

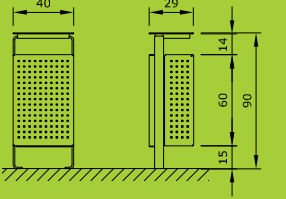

mod. 2050L/A

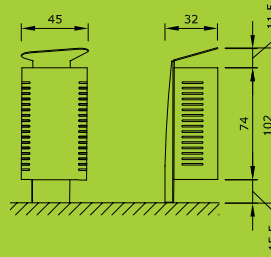

mod. 1050

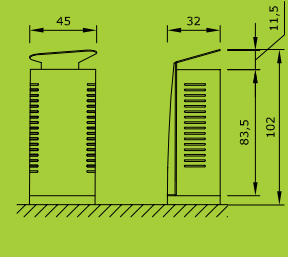

mod. 1060

descrizione tecnica e disegni dwg | technische Beschreibung und dwg Zeichnungen | technical description and dwg drawings | description technique et dessins dwg: [www.euroform-w.com](http://www.euroform-w.com)



Zenith St Etienne, France



Sant'Anastasia, Napoli, Italy

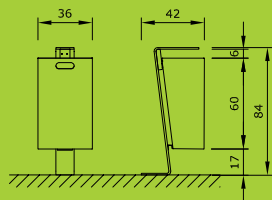

mod. 2400

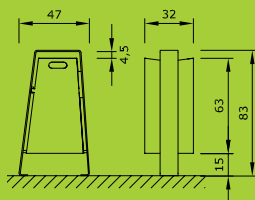

mod. 2405

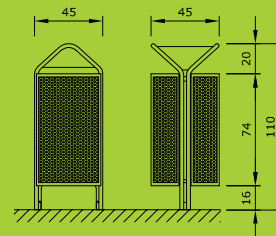

mod. 2010M | 2010M/A

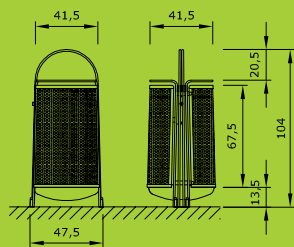

mod. 272

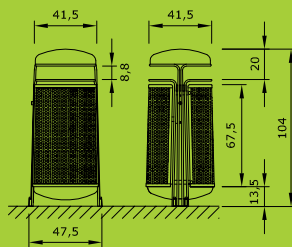

mod. 273 | 273A

descrizione tecnica e disegni dwg | technische Beschreibung und dwg Zeichnungen | technical description and dwg drawings | description technique et dessins dwg: [www.euroform-w.com](http://www.euroform-w.com)



## zetacestino

mod. 2400, 2405



Peso | Gewicht | Poids | Weight: 24 kg | 26 kg  
Capacità | Inhalt | Contenance | Capacity: 45 l, 55 l

## ambiente

mod. 272, 273, 273A



Peso | Gewicht | Poids | Weight: 24 | 27 kg  
Capacità | Inhalt | Contenance | Capacity: 60 l | 60 l

**ZETACESTINO: Telaio:** ferro piatto 12x120 mm, zincato.  
**Contentitore:** lamiera zincata spess. 1,2 mm.  
**SCALA: Telaio:** tubo d'acciaio Ø25 mm zincato a fuoco.  
**Copertura:** ferro d'acciaio 2 mm. **Rivestimento:** lamiera stirata di 1,5 mm, bordo arrotondato, spess. 6,5 mm.  
**AMBIENTE: Telaio:** 4 ferri tondi trafilati da 12 mm zincati.  
**Coperchio:** lamiera decapata, fondo stampato spess. 2 mm.  
**Rivestimento:** lamiera stirata di 1,5 mm, bordo arrotondato spess. 6,5 mm. **Serratura:** con chiave a triangolo, autochiudente. **Trattamento a polvere:** Colori RAL a scelta. **Fissaggio:** in calcestruzzo, su pavimento solido o per collocamento libero.

**ZETACESTINO: Ossature:** fer plat 12x120 mm, galvanisé à chaud. **Habilage:** acier 1,2 mm. **SCALA: Ossature:** tube d'acier Ø25 mm galvanisé à chaud.

## scala

mod. 2010M, 2010M/A



Peso | Gewicht | Poids | Weight: 40 kg  
Capacità | Inhalt | Contenance | Capacity: 50 l

**Couvercle:** acier - fond moulé épaisseur 2 mm. **Habilage:** métal déployé 1,5 mm - avec rebord de 6,5 mm d'épaisseur. **AMBIENTE: Ossature:** fer plein Ø12 mm galvanisé. **Couvercle:** acier - fond moulé épaisseur 2 mm. **Habilage:** métal déployé 1,5 mm - avec rebord de 6,5 mm d'épaisseur. **Verrouillage:** Avec clé triangulaire - fermeture automatique. **Revêtement poudre polyester:** Coloris RAL au choix. **Scellement:** Dans le sol, en surface ou autostable.

**ZETACESTINO: Gestell:** Flacheisen 12x120 mm, verzinkt. **Behälter:** Stahlblech 1,2 mm verzinkt.  
**SCALA: Gestell:** Stahlrohr Ø25 mm feuerverzinkt. **Abdeckung:** Stahlblech 2 mm. **Ummantelung:** Streckmetall 1,5 mm, mit U-Profil 6,5 mm gerändelt. **AMBIENTE: Gestell:** 4 Rundeisen 12 mm verzinkt. **Abdeckung:** Stahlblech-Presseteil 2 mm. **Ummantelung:** Streckmetall 1,5 mm, mit U-Profil 6,5 mm gerändelt. **Verriegelung:** mit Dreikantschlüssel, selbstschliessend. **Pulverbeschichtung:** RAL-Farben nach Wahl. **Befestigung:** zum Einbetonieren, zum Aufschrauben oder zum freien Aufstellen.

**ZETACESTINO: Frame:** flat bar 12x120 mm, galvanized. **Receptacle:** steel sheet 1.2 mm, galvanized.  
**SCALA: Frame:** tubular steel Ø25 mm. **Casing:** 1,5 mm expanded metal sides, rounded edging 6,5 mm thick. **Cover:** from metal depth 2 mm. **AMBIENTE: Frame:** 12 mm round steel frame, galvanized. **Casing:** 1,5 mm expanded metal sides, rounded edging 6,5 mm thick. **Cover:** from metal depth 2 mm. **Closing:** triangular key, self-closing. **Powder coating:** RAL colour to choose. **Fixation:** fixed in the ground, surface mounting, free-standing.

## comfort

mod. 610



Peso | Gewicht | Poids | Weight: 21 kg  
Capacità | Inhalt | Contenance | Capacity: 60 l

## comfort

mod. 615



Peso | Gewicht | Poids | Weight: 25 kg  
Capacità | Inhalt | Contenance | Capacity: 60 l

## comfort

mod. 865



Peso | Gewicht | Poids | Weight: 36 kg  
Capacità | Inhalt | Contenance | Capacity: 80 l

**Telaio:** ferro piatto 8x50 mm zincato. **Rivestimento:** lamiera forata spess. 2 mm zincato, con porta per lo svuotamento. **Copertura:** lamiera d'acciaio 6 mm. **Serratura:** con chiave a triangolo, autochiudente. **Trattamento a polvere:** Colori RAL a scelta. **Fissaggio:** in calcestruzzo, su pavimento solido o per collocamento libero.

**Ossature:** fer plat 8x50 mm galvanisé. **Couvercle:** tôle perforée 2 mm, galvanisé. **Couvercle:** en acier 6 mm. **Verrouillage:** Avec clé triangulaire – fermeture automatique. **Revêtement poudre polyester:** Coloris RAL au choix. **Scellement:** Dans le sol, en surface ou autostable.

## comfort

mod. 866

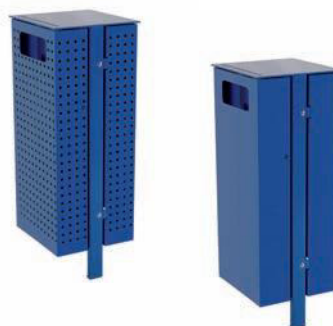

Peso | Gewicht | Poids | Weight: 37 kg  
Capacità | Inhalt | Contenance | Capacity: 70 l

**Gestell:** Flacheisen 8x50 mm, verzinkt. **Ummantelung:** Lochblech 2 mm verzinkt, mit Tür für die Entleerung. **Abdeckung:** Stahlblech 6 mm. **Verriegelung:** mit Dreikantschlüssel, selbstschliessend. **Pulverbeschichtung:** RAL-Farben nach Wahl. **Befestigung:** zum Einbetonieren, zum Aufschrauben oder zum freien Aufstellen.

**Frame:** flat bar 8x50 mm, galvanized. **Panelling:** perforated metal sheet 2 mm, galvanized, with door for emptying. **Cover:** metal sheet 6 mm. **Closing:** triangular key, self-closing. **Powder coating:** RAL colour to choose. **Fixation:** fixed in the ground, surface mounting, free-standing.

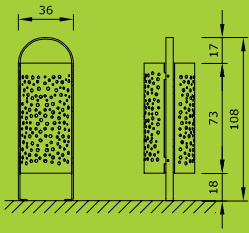

mod. 610

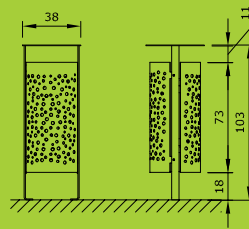

mod. 615

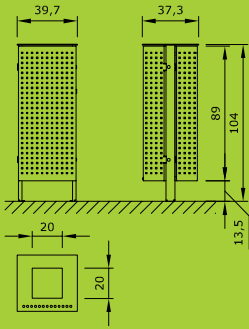

mod. 865

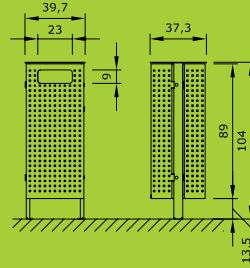

mod. 866

descrizione tecnica e disegni dwg | technische Beschreibung und dwg Zeichnungen | technical description and dwg drawings | description technique et dessins dwg: [www.euroform-w.com](http://www.euroform-w.com)





Sheffield City Council, England

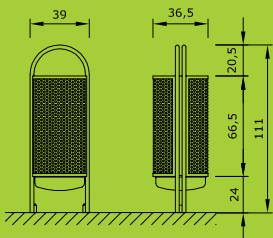

mod. 275

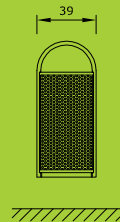

mod. 275W

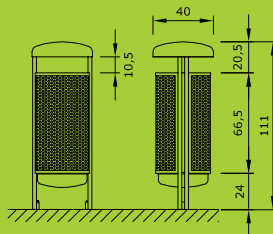

mod. 276 | 276A

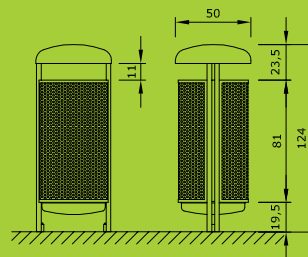

mod. 276/120

descrizione tecnica e disegni dwg | technische Beschreibung und dwg Zeichnungen | technical description and dwg drawings | description technique et dessins dwg: [www.euroform-w.com](http://www.euroform-w.com)

## contour

mod. 275



Peso | Gewicht | Poids | Weight: 18 kg  
Capacità | Inhalt | Contenance | Capacity: 60 l

## contour

mod. 275W



Peso | Gewicht | Poids | Weight: 17 kg  
Capacità | Inhalt | Contenance | Capacity: 50 l

## contour

mod. 276



Peso | Gewicht | Poids | Weight: 26 kg  
Capacità | Inhalt | Contenance | Capacity: 60 l

## contour

mod. 276/120



Peso | Gewicht | Poids | Weight: 37 kg  
Capacità | Inhalt | Contenance | Capacity: 120 l

**Telaio:** tubo d'acciaio Ø25 mm zincato a fuoco. **Coperchio:** metallo, fondo stampato spess. 2 mm. **Rivestimento:** lamiera stirata da 1,5 mm, bordo arrotondato, spess. 6,5 mm. **Serratura:** con chiave a triangolo, autochiudente. **Trattamento a polvere:** Colori RAL a scelta. **Fissaggio:** in calcestruzzo, su pavimento solido o per collocamento libero.

**Ossature:** tube d'acier Ø25 mm galvanisé à chaud. **Couvercle:** acier - fond moulé épaisseur 2 mm. **Habillage:** métal déployé 1,5 mm - avec rebord de 6,5 mm d'épaisseur. **Verrouillage:** Avec clé triangulaire - fermeture automatique. **Revêtement poudre polyester:** Coloris RAL au choix. **Scellement:** Dans le sol, en surface ou autostable.

**Gestell:** Stahlrohr Ø25 mm feuerverzinkt. **Abdeckung:** Stahlblech-Pressenteil 2 mm. **Ummantelung:** Streckmetall 1,5 mm, mit U-Profil 6,5 mm gerändelt. **Verriegelung:** mit Dreikantschlüssel, selbstschliessend. **Pulverbeschichtung:** RAL-Farben nach Wahl. **Befestigung:** zum Einbetonieren, zum Aufschrauben oder zum freien Aufstellen.

**Frame:** tubular steel Ø25 mm hot-dip galvanized. **Casing:** 1,5 mm expanded metal sides, rounded edging 6,5 mm thick. **Cover:** from metal depth 2 mm. **Closing:** triangular key, self-closing. **Powder coating:** RAL colour to choose. **Fixation:** fixed in the ground, surface mounting, free-standing.

# tulip

mod. 230/60, 230/90

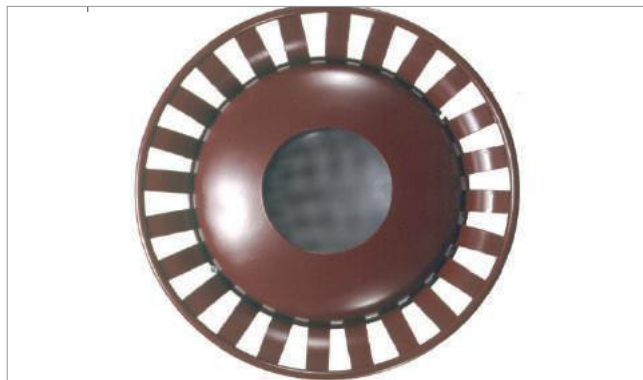

Peso | Gewicht | Poids | Weight: 45 kg | 52 kg  
Capacità | Inhalt | Contenance | Capacity: 60 l | 90 l

**TULIP: Corpo:** ferri piatti 35x6 mm, ferro tondo spess. 15 mm, zincato. **Coperchio:** metallo, fondo stampato spess. 2 mm. **Serratura:** con chiave a triangolo, autochiudente. **Trattamento a polvere:** Colori RAL a scelta. **Fissaggio:** in calcestruzzo, su pavimento solido o per collocamento libero.



**TULIP: Korpus:** Flacheisen 35x6 mm, Rundeisen 15 mm, verzinkt. **Abdeckung:** Stahlblech-Presssteile 2 mm. **Verriegelung:** mit Dreikantschlüssel, selbstschliessend. **Pulverbeschichtung:** RAL-Farben nach Wahl. **Befestigung:** zum Einbetonieren, zum Aufschrauben oder zum freien Aufstellen.

**TULIP: Ossature:** fer plat de 35x6 mm - fer rond Ø15 mm galvanisé. **Couvercle:** en acier - fond moulé de 2 mm d'épaisseur. **Verrouillage:** Avec clé triangulaire - fermeture automatique. **Revêtement poudre polyester:** Coloris RAL au choix. **Scellement:** Dans le sol, en surface ou autostable.



**TULIP: Frame:** flatbar frame 35x6 mm, 15 mm round steel galvanized. **Cover:** from metal depth 2 mm. **Closing:** triangular key, self-closing. **Powder coating:** RAL colour to choose. **Fixation:** fixed in the ground, surface mounting, free-standing.

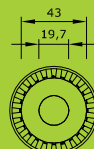
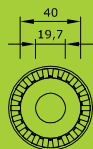
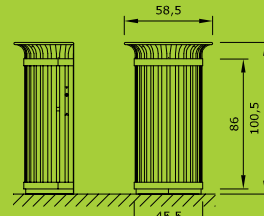
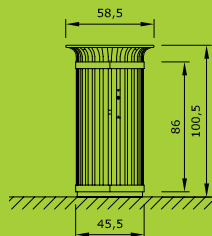
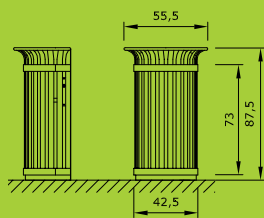
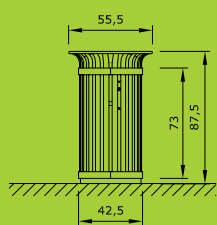

mod. 230/90  
mod. 230/90W

mod. 230/60  
mod. 230/60W

descrizione tecnica e disegni dwg | technische Beschreibung und dwg Zeichnungen | technical description and dwg drawings | description technique et dessins dwg: [www.euroform-w.com](http://www.euroform-w.com)



Arcachon, France



Nóra, Cagliari, Italy

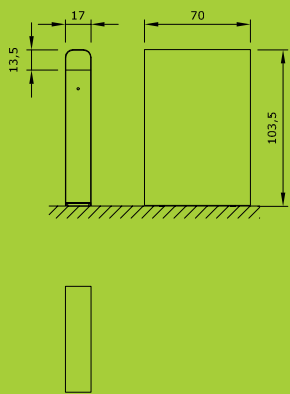

mod. 2600

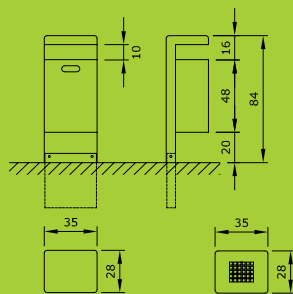

mod. 270V/43 | mod. 270VA/43

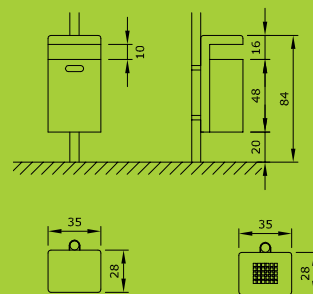

mod. 270MV/43 | mod. 270MVA/43

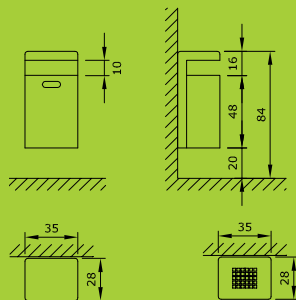

mod. 270WV/43 | mod. 270WVA/43

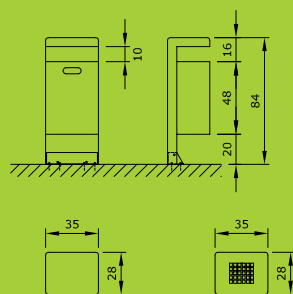

mod. 270BV/43 | mod. 270BVA/43

descrizione tecnica e disegni dwg | technische Beschreibung und dwg Zeichnungen | technical description and dwg drawings | description technique et dessins dwg: [www.euroform-w.com](http://www.euroform-w.com)



## band

mod. 2600

ad-  
vertis-  
ment



Peso | Gewicht | Poids | Weight: 56 kg  
Capacità | Inhalt | Contenance | Capacity: 80 l

## simple

mod. 270/43



Peso | Gewicht | Poids | Weight: 20 kg  
Capacità | Inhalt | Contenance | Capacity: 43 l

**BAND: Contenitore:** lamiera d'acciaio spess. 3 mm, zincato a fuoco.

**SIMPLE: Telaio e coperchio parapiovra:** realizzati in profilo stampato a forma di "U" in lamiera decapata da 2,5 mm zincata a fuoco, con serratura incorporata nel telaio. **Contenitore:** estraibile a forma rettangolare in lamiera come sopra da 1,5 mm con bordo superiore piegato e fondo forato. Nella parte superiore 1 foro ovale che serve da impugnatura per lo svuotamento. **Serratura:** con chiave a triangolo, autochiudente. **Trattamento a polvere:** Colori RAL a scelta. **Fissaggio:** in calcestruzzo, su pavimento solido o per collocamento libero.

**BAND: Bac:** acier 3 mm, galvanisé à chaud.

**Ossature et protège pluie:** réalisés en fers plats en forme de « U » et tôle d'acier d'une épaisseur de 2,5 mm galvanisée à chaud, fermeture automatique avec protège pluie. **Seau:** amovible et de forme rectangulaire en tôle d'acier d'épaisseur 1,5 mm avec bord supérieur plié et fond perforé. Un trou ovale dans la partie supérieure sert de poignée pour la maintenance. **Verrouillage:** Avec clé triangulaire – fermeture automatique. **Revêtement poudre polyester:** Coloris RAL au choix. **Scellement:** Dans le sol, en surface ou autostable.

**BAND: Behälter:** Stahlblech 3 mm, feuerverzinkt.

**SIMPLE: Gestell:** aus einem U-förmig gepreßten Stahlblechteil 2,5 mm, mit einem tiefgezogenen Stahlblechteil als Abdeckung. **Aschenbecher:** in Abdeckung integriert, mit eigener Dreikantverriegelung. **Behälter:** aus gepreßtem Stahlblech 1,5 mm, mit Griffloch zum Entleeren, oberer Behälterrund gebördelt. **Verriegelung:** mit Dreikantschlüssel, selbstschliessend. **Pulverbeschichtung:** RAL-Farben nach Wahl. **Befestigung:** zum Einbetonieren, zum Aufschrauben oder zum freien Aufstellen.

**BAND: Container:** steel sheet 3 mm, hot-dip galvanized.

**SIMPLE: Frame:** made of a U-shaped pressed part made of galvanized steel sheet 2,5 mm. **Cover:** made of a hot-dip galvanized sheet steel part with a built-in self-closing triangular lock available with or without ashtray. **Container:** made of galvanized steel sheet 1,5 mm with hole for emptying and bottom is perforated. Upper edges of the frame and the container with rolled edge. **Closing:** triangular key, self-closing. **Powder coating:** RAL colour to choose. **Fixation:** fixed in the ground, surface mounting, free-standing.

## simple

mod. 220V, 220W, 220M



Peso | Gewicht | Poids | Weight: 15 kg | 15kg | 15 kg  
Capacità | Inhalt | Contenance | Capacity: 40 l

## simple

mod. 221V, 221W, 221M, 221V/A



Peso | Gewicht | Poids | Weight: 17 kg | 17 kg | 17 kg  
Capacità | Inhalt | Contenance | Capacity: 40 l

## simple+

mod. 225V, 225W, 225M



Peso | Gewicht | Poids | Weight: 15 kg | 15 kg | 15 kg  
Capacità | Inhalt | Contenance | Capacity: 40 l

**Telaio:** lamiera d'acciaio 2,5 mm zincato a fuoco. **Rivestimento:** lamiera d'acciaio 1,2 mm o lamiera forata 1,2 mm. **Coperchio:** lamiera d'acciaio 6 mm (mod. 221: fondo stampato 2 mm). **Serratura:** con chiave a triangolo, autochiudente. **Trattamento a polvere:** Colori RAL a scelta. **Fissaggio:** in calcestruzzo, su pavimento solido.

**Ossature:** fer plat 2,5 mm galvanisé à chaud. **Couvercle:** acier - fond moulé épaisseur 2 mm. **Ossature:** fer plat 1,2 mm o tole perforée 1,2 mm. **Couvercle:** fer plat 6 mm (mod. 221: en acier - fond moulé épaisseur 2 mm). **Verrouillage:** Avec clé triangulaire – fermeture automatique. **Revêtement poudre polyester:** Coloris RAL au choix. **Scellement:** Dans le sol, en surface ou autostable.

## simple+

mod. 226V, 226W, 226M



Peso | Gewicht | Poids | Weight: 17 kg | 17 kg | 17 kg  
Capacità | Inhalt | Contenance | Capacity: 40 l

**Gestell:** Stahlblech 2,5 mm feuerverzinkt. **Ummantelung:** Stahlblech 1,2 mm oder Lochblech 1,2 mm. **Abdeckung:** Stahlblech 6 mm (mod. 221: Stahlblech Pressteil 2 mm). **Verriegelung:** mit Dreikantschlüssel, selbstschliessend. **Pulverbeschichtung:** RAL-Farben nach Wahl. **Befestigung:** zum Einbetonieren, zum Aufschrauben oder zum freien Aufstellen.

**Frame:** steel sheet 2,5 mm hot-dip galvanized. **Casing:** steel sheet 1,2 mm or perforated metal 1,2 mm hot-dip galvanized. **Cover:** steel sheet 6 mm, (mod. 221: metal depth 2 mm). **Closing:** triangular key, self-closing. **Powder coating:** RAL colour to choose. **Fixation:** fixed in the ground, surface mounting.

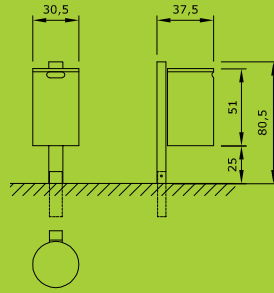

mod. 220V

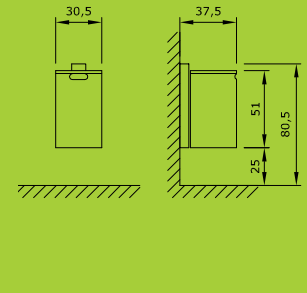

mod. 220W

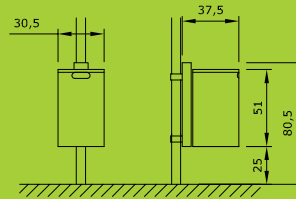

mod. 220M

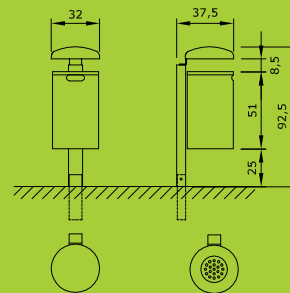

mod. 221V | 221V/A

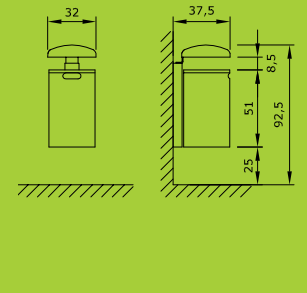

mod. 221W

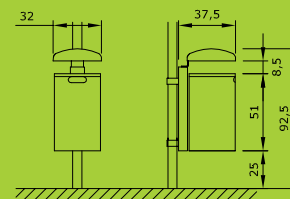

mod. 221M

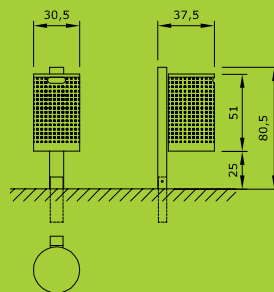

mod. 225V

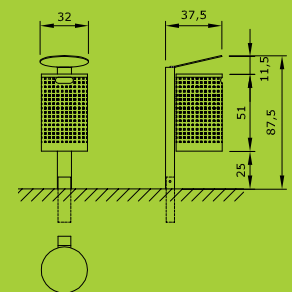

mod. 226V

descrizione tecnica e disegni dwg  
 technische Beschreibung und dwg Zeichnungen  
 technical description and dwg drawings  
 description technique et dessins dwg:  
[www.euroform-w.com](http://www.euroform-w.com)

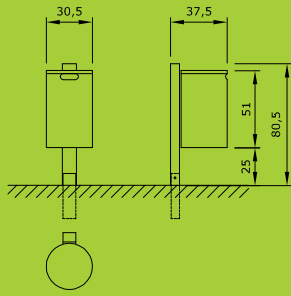

mod. 220VL

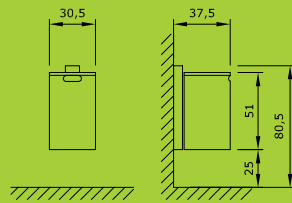

mod. 220WL

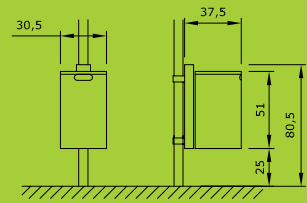

mod. 220ML

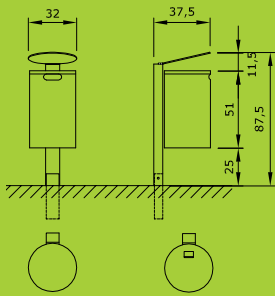

mod. 221VL | 221VL/A

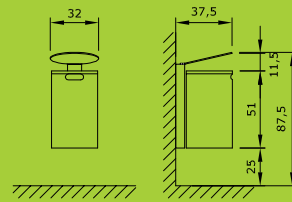

mod. 221WL

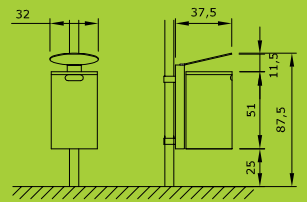

mod. 221ML

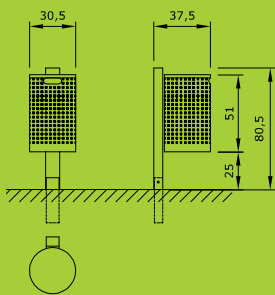

mod. 225VL

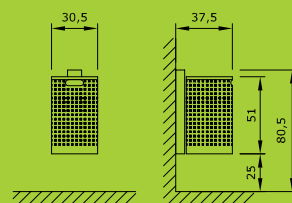

mod. 225WL

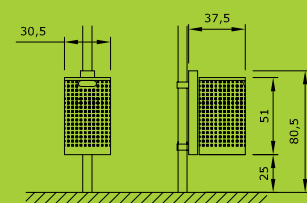

mod. 225ML

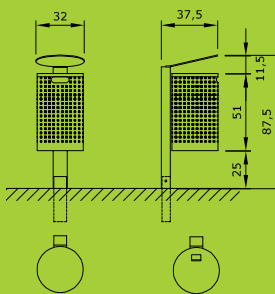

mod. 226VL | 226VL/A

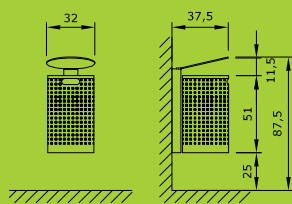

mod. 226WL

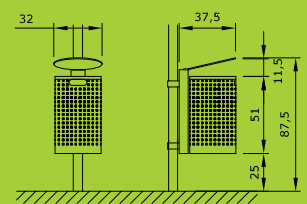

mod. 226ML

descrizione tecnica e disegni dwg | technische Beschreibung und dwg Zeichnungen | technical description and dwg drawings | description technique et dessins dwg: [www.euroform-w.com](http://www.euroform-w.com)

## simple light

mod. 220VL, 220WL, 220ML



Peso | Gewicht | Poids | Weight: 10 kg | 10 kg | 10 kg  
Capacità | Inhalt | Contenance | Capacity: 40 l

## simple light

mod. 221VL, 221WL, 221ML, 221VL/A



Peso | Gewicht | Poids | Weight: 13 kg | 13 kg | 13 kg  
Capacità | Inhalt | Contenance | Capacity: 40 l

## simple+ light

mod. 225VL, 225WL, 225ML



Peso | Gewicht | Poids | Weight: 10 kg | 10 kg | 10 kg  
Capacità | Inhalt | Contenance | Capacity: 40 l

**Telaio:** lamiera d'acciaio 2 mm zincato. **Rivestimento:** lamiera d'acciaio 1,2 mm o lamiera forata 1,2 mm zincato. **Coperchio:** lamiera d'acciaio 6 mm. **Serratura:** con chiave a triangolo, autochiudente. **Trattamento a polvere:** Colori RAL a scelta. **Fissaggio:** in calcestruzzo, su pavimento solido.

**Ossature:** fer plat 2 mm galvanisé. **Couvercle:** acier - fond moulé épaisseur 2 mm. **Ossature:** fer plat 1,2 mm o tole perforée 1,2 mm galvanisé. **Couvercle:** fer plat 6 mm. **Verrouillage:** Avec clé triangulaire – fermeture automatique. **Revêtement poudre polyester:** Coloris RAL au choix. **Scellement:** Dans le sol, en surface ou autostable.

## simple+ light

mod. 226VL, 226WL, 226ML, 226VL/A



Peso | Gewicht | Poids | Weight: 13 kg | 13 kg | 13 kg  
Capacità | Inhalt | Contenance | Capacity: 40 l

**Gestell:** Stahlblech 2 mm verzinkt. **Ummantelung:** Stahlblech 1,2 mm oder Lochblech 1,2 mm verzinkt. **Abdeckung:** Stahlblech 6 mm. **Verriegelung:** mit Dreikantschlüssel, selbstschliessend. **Pulverbeschichtung:** RAL-Farben nach Wahl. **Befestigung:** zum Einbetonieren, zum Aufschrauben oder zum freien Aufstellen.

**Frame:** steel sheet 2,5 mm, galvanized. **Casing:** steel sheet 1,2 mm or perforated metal 1,2 mm, galvanized. **Cover:** steel sheet 6 mm. **Closing:** triangular key, self-closing. **Powder coating:** RAL colour to choose. **Fixation:** fixed in the ground, surface mounting.

simple+

mod. 2090A



Peso | Gewicht | Poids | Weight: 65 kg  
Capacità | Inhalt | Contenance | Capacity: 120 l

**Telaio:** tubo rettangolare 15x60 mm zincato a fuoco. **Coperchio parapioggia:** spess. 6 mm con posacenere incorporato. **Rivestimento:** in lamiera d'acciaio o lamiera d'acciaio forata spess. 2,5 mm, fori 10x10 mm, zincato. **Serratura:** con chiave a triangolo, autochiudente. **Trattamento a polvere:** Colori RAL a scelta. **Fissaggio:** in calcestruzzo, su pavimento solido o per collocamento libero.

**Ossature:** tube d'acier 15x60 mm galvanisé à chaud. **Couvercle:** fer plat 6 mm avec cendrier. **Habillage:** Tôle galvanisée d'acier ou tôle perforée 2,5 mm, 10x10 mm d'alésage. **Verrouillage:** Avec clé triangulaire – fermeture automatique. **Revêtement poudre polyester:** Coloris RAL au choix. **Scellement:** Dans le sol, en surface ou autostable.

simple+

mod. 2091A



Peso | Gewicht | Poids | Weight: 42 kg  
Capacità | Inhalt | Contenance | Capacity: 120 l

**Gestell:** Rechteckrohr 15x60 mm, feuerverzinkt. **Abdeckung:** Stahlblech 6 mm mit integriertem Aschenbecher. **Ummantelung:** Stahlblech oder Lochblech 2,5 mm verzinkt, 10x10 mm Bohrung. **Verriegelung:** mit Dreikantschlüssel, selbstschliessend. **Pulverbeschichtung:** RAL-Farben nach Wahl. **Befestigung:** zum Einbetonieren, zum Aufschrauben oder zum freien Aufstellen.

**Frame:** Steel tube 15x60 mm, hot-dip galvanized. **Cover:** steel sheet 6 mm with integrated ashtray. **Panelling:** galvanized steel sheet or perforated metal 2,5 mm, 10x10 mm holes. **Closing:** triangular key, self-closing. **Powder coating:** RAL colour to choose. **Fixation:** fixed in the ground, surface mounting, free-standing.

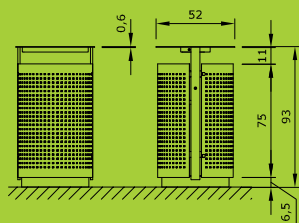

mod. 2090A

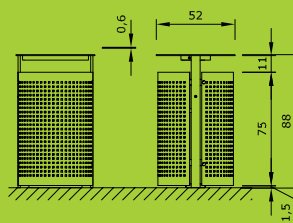

mod. 2091A

descrizione tecnica e disegni dwg | technische Beschreibung und dwg Zeichnungen | technical description and dwg drawings | description technique et dessins dwg: [www.euroform-w.com](http://www.euroform-w.com)



Orta San Giulio, Novara, Italy

fritz

mod. 218



Peso | Gewicht | Poids | Weight: 20 kg  
Capacità | Inhalt | Contenance | Capacity: 40 l

**FRITZ: Telaio:** palo in tubo d'acciaio Ø76 mm. **Copertura:** alluminio fusione in sabbia resistente alle acque saline. **Coperchio:** lamiera d'acciaio 6 mm. **Rivestimento:** lamiera d'acciaio 1,2 mm zincato. **EDDY: Rivestimento:** lamiera d'acciaio 2,5 mm. **Fondo:** ferro piatto 8x50 mm. **Serratura:** con chiave a triangolo, autochiudente. **Trattamento a polvere:** Colori RAL a scelta. **Fissaggio:** in calcestruzzo, su pavimento solido o per collocamento libero.

**FRITZ: Ossature:** poster faite de tubulaire Ø76 mm. **Cap:** aluminium sablé résistant à l'eau de mer. **Couvercle:** tôle d'acier 6 mm. **Habillage:** tôle d'acier galvanisée 1,2 mm. **EDDY: Couverture:** tôle d'acier de 2,5 mm. **Fonds:** fer plat 8x50 mm. **Verrouillage:** Avec clé triangulaire – fermeture automatique. **Revêtement poudre polyester:** Coloris RAL au choix. **Scellement:** Dans le sol, en surface ou autostable.

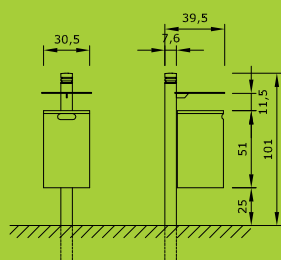

mod. 218

eddy

mod. 1080



Peso | Gewicht | Poids | Weight: 49 kg  
Capacità | Inhalt | Contenance | Capacity: 120 l

**FRITZ: Gestell:** Pfosten aus Rundrohr Ø76 mm. **Kappe:** seewasserbeständige Aluminiumsandgusslegierung. **Abdeckung:** Stahlblech 6 mm. **Ummantelung:** Stahlblech 1,2 mm verzinkt. **EDDY: Korpus:** Stahlblech 2,5 mm. **Sockel:** Flacheisen 8x50 mm. **Verriegelung:** mit Dreikantschlüssel, selbstschliessend. **Pulverbeschichtung:** RAL-Farben nach Wahl. **Befestigung:** zum Einbetonieren, zum Aufschrauben oder zum freien Aufstellen.

**FRITZ: Frame:** post in tube circular Ø76 mm. **Cover:** in aluminum alloy sand casting resistant against seawater. **Cover:** Sheet steel 6 mm. **Sheathing:** galvanized steel sheet 1,2 mm. **EDDY: Body:** steel sheet 2,5 mm. **Pedestal:** flat iron 8x50 mm. **Closing:** triangular key, self-closing. **Powder coating:** RAL colour to choose. **Fixation:** fixed in the ground, surface mounting, free-standing.

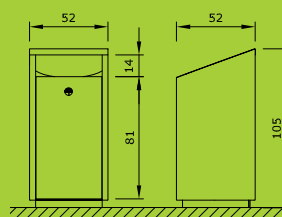

mod. 1080

descrizione tecnica e disegni dwg | technische Beschreibung und dwg Zeichnungen | technical description and dwg drawings | description technique et dessins dwg: [www.euroform-w.com](http://www.euroform-w.com)





# cestini raccolta differenziata | mülltrennbehälter corbeilles de tri sélectif | waste recycling bin

## Tutto in ordine

I nostri cestini per la raccolta differenziata consentono la raccolta professionale di due o tre diversi tipi di rifiuti. Le scritte sono a scelta libera

## Geordnete Sauberkeit

Unsere Mülltrennbehälter ermöglichen das professionelle Sammeln von zwei oder drei getrennten Arten von Müll bzw. Abfall. Die Beschriftung ist frei wählbar.

## Un tri selectif

Le corbeilles de tri sélectif permettent de recevoir et trier deux o trois types de déchets d'une manière professionnelle et judicieuse. Le lettrage au choix libre.

## A matter of cleanliness

Our waste recycling bins allows two or three different types of waste to be collected in individual compartments. The labeling can be freely selected.



# band eco

mod. 2620



Peso | Gewicht | Poids | Weight: 59 kg

Capacità | Inhalt | Contenance | Capacity: 40+40 l

**Contenitore:** lamiera d'acciaio spess. 3 mm, zincato a fuoco. **Serratura:** con chiave a triangolo, autochiudente. **Trattamento a polvere:** Colori RAL a scelta. **Fissaggio:** in calcestruzzo, su pavimento solido o per collocamento libero.

**Seau:** acier galvanisé à chaud 3 mm. **Verrouillage:** Avec clé triangulaire – fermeture automatique. **Revêtement poudre polyester:** Coloris RAL au choix. **Scellement:** Dans le sol, en surface ou autostable.

**Behälter:** Stahlblech 3 mm, feuerverzinkt. **Verriegelung:** mit Dreikantschlüssel, selbstschliessend. **Pulverbeschichtung:** RAL-Farben nach Wahl. **Befestigung:** zum Einbetonieren, zum Aufschrauben oder zum freien Aufstellen.

**Container:** steel sheet 3 mm, hot-dip galvanized. **Closing:** triangular key, self-closing. **Powder coating:** RAL colour to choose. **Fixation:** fixed in the ground, surface mounting and free-standing.

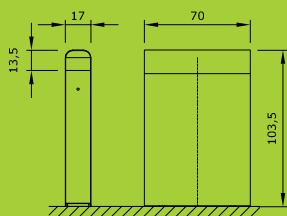

mod. 2620

descrizione tecnica e disegni dwg | technische Beschreibung und dwg Zeichnungen | technical description and dwg drawings | description technique et dessins dwg: [www.euroform-w.com](http://www.euroform-w.com)

# ecology

mod. 293



Peso | Gewicht | Poids | Weight: 96 kg  
Capacità | Inhalt | Contenance | Capacity: 3x65 l

**Telaio:** ferro piatto 10x60 mm, zincato. **Coperchio:** in lamiera d'acciaio 6 mm. **Rivestimento:** lamiera forata da 2 mm. **Serratura:** con chiave a triangolo, autochiudente. **Trattamento a polvere:** Colori RAL a scelta. **Fissaggio:** in calcestruzzo, su pavimento solido o per collocamento libero.

**Ossature:** fer plat 10x60 mm galvanisé. **Couvercle:** En acier épaisseur 6 mm. **Habillage:** En tôle perforée 2 mm. **Verrouillage:** Avec clé triangulaire – fermeture automatique. **Revêtement poudre polyester:** Coloris RAL au choix. **Scellement:** Dans le sol, en surface ou autostable.

**Gestell:** Flacheisen 10x60 mm verzinkt. **Abdeckung:** Stahlblech 6 mm. **Ummantelung:** Lochblech 2 mm. **Verriegelung:** mit Dreikantschlüssel, selbstschliessend. **Pulverbeschichtung:** RAL-Farben nach Wahl. **Befestigung:** zum Einbetonieren, zum Aufschrauben oder zum freien Aufstellen.

**Frame:** flat iron 10x60 mm, galvanized. **Cover:** steel sheet 6 mm. **Facing:** perforated steel thickness 2 mm. **Closing:** triangular key, self-closing. **Powder coating:** RAL colour to choose. **Fixation:** fixed in the ground, surface mounting, free-standing.

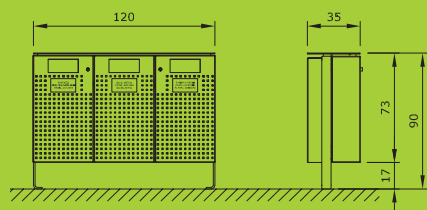

mod. 293

descrizione tecnica e disegni dwg | technische Beschreibung und dwg Zeichnungen | technical description and dwg drawings | description technique et dessins dwg: [www.euroform-w.com](http://www.euroform-w.com)



# contenitore per deiezione canine | hundekotbehälter corbeilles pour déjections canines | service container for dogs

## Un sistema pulito

Con il contenitore Dogy Clean le strade, i marciapiedi e parchi rimangono belli e puliti. Un contenitore interno con sacchetti in plastica facilita l'eliminazione delle deiezioni canine in modo semplice e garantisce funzionalità e consenso da parte dei proprietari dei cani.

## Eine saubere Sache

Mit Dogy Clean bleiben Straßen, Gehsteige, Plätze und Parks sauber und schön. Ein integrierter Beutel-Spender macht die Kot-Entsorgung kinderleicht und sorgt für eine gute Funktionalität und hohe Akzeptanz bei Hundebesitzern. Das ansprechende, geradlinige Design von Dogy Clean lässt sich in jede Art von Umgebung optimal integrieren.

## Question de propreté

Avec « Dogy Clean », les rues, les trottoirs, les places et les parcs sont enfin propres. Un distributeur intégré de sacs plastiques facilite l'opération de nettoyage, grâce à un système fonctionnel bien accepté par les propriétaires de chiens. De plus, le design discret du « Dogy Clean » permet une intégration parfaite dans tous types d'environnement.

## A clean affair

Streets, pavements, squares and parks can be kept nice and clean with the Dogy Clean unit. An integrated bag dispenser makes it really easy to dispose of excrement, ensuring both high functionality and acceptance among dog owners. With its attractive yet simple design, the Dogy Clean unit fits perfectly into any environment.



# dogy clean

mod. 281



Peso | Gewicht | Poids | Weight: 36 kg  
Capacità | Inhalt | Contenance | Capacity: 25 l

**Telaio:** Lamiera d'acciaio 2,5 mm. **Contenitore:** lamiera d'acciaio 2 mm. **Serratura:** con chiave a triangolo, autochiudente. **Trattamento a polvere:** RAL6005 o colori RAL a scelta. **Fissaggio:** in calcestruzzo, su pavimento solido o per collocamento libero.

**Ossature:** tôle d'acier 2,5 mm galvanisé à chaud. **Couvercle:** tôle d'acier 2 mm, galvanisé à chaud. **Verrouillage:** Avec clé triangulaire – fermeture automatique. **Revêtement poudre polyester:** RAL6005 ou coloris RAL au choix. **Scellement:** Dans le sol, en surface ou autostable.



**Gestell:** Stahlblech 2,5 mm. **Behälter** Stahlblech 2 mm feuerverzinkt. **Verriegelung:** mit Dreikantschlüssel, selbst-schliessend. **Pulverbeschichtung:** RAL6005 oder RAL-Farben nach Wahl. **Befestigung:** zum Einbetonieren, zum Aufschrauben oder zum freien Aufstellen.

**Frame:** Steel sheet 2,5 mm hot-dip galvanized. **Casing:** steel sheet 2 mm, hot-dip galvanized. **Closing:** triangular key, self-closing. **Powder coating:** RAL 6005 or RAL colour to choose. **Fixation:** fixed in the ground, surface mounting.

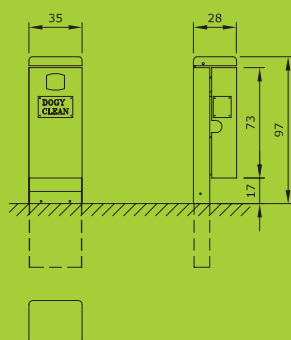

mod. 281

descrizione tecnica e disegni dwg | technische Beschreibung und dwg Zeichnungen | technical description and dwg drawings | description technique et dessins dwg: [www.euroform-w.com](http://www.euroform-w.com)

# portacenere | freiraum ascher | cendries en acier ashtrays

## Una cosa pulita

I nostri portacenere contribuiscono ad un ambiente pulito. La possibilità otticamente invitante di smaltire le sigarette viene accettata volentieri dai passanti. Le strade, vie e prati rimangono puliti e belli da vedere.

## Aufgeräumt

Unsere Freiraum-Ascher sorgt für eine saubere Umwelt. Die optisch einladende Möglichkeit zur Zigaretten-Entsorgung wird von Passanten gerne angenommen. Es bleiben somit Straßen, Wege und Wiesen sauber und weiterhin schön anzusehen.

## L'environnement épargné

Notre cendriers en acier sont la solution qui invite les fumeurs à respecter l'environnement, en évitant la pollution des trottoirs, places publiques... par des mégots de cigarettes.

## A matter of cleanliness

Our ashtrays ensures a clean environment. The visually attractive ashtray is well accepted by passers-by. So its helps to keep streets, paths and lawns clean and nice looking.





## lineafumo

mod. 540V, 540M, 540B, 540W



Peso | Gewicht | Poids | Weight: 26 | 6 | 23 | 6 kg

**Telaio:** ferro piatto 15x60 mm (light: 10x60 mm) zincato a fuoco. **Corpo:** lamiera d'acciaio spess. 3 mm, zincato a fuoco. **Serratura:** con chiave a triangolo, autochiudente. **Trattamento a polvere:** Colori RAL a scelta. **Fissaggio:** in calcestruzzo, su pavimento solido o per collocamento libero, fissaggio su palo, fissaggio a parete.

**Ossature:** fer plat 15x60 mm (light: 10x60 mm), galvanisé à chaud. **Corps du cendrier:** acier 3 mm galvanisé à chaud. **Verrouillage:** Avec clé triangulaire – fermeture automatique. **Revêtement poudre polyester:** Coloris RAL au choix. **Scellement:** Dans le sol, en surface, autostable, sur poteau, ou sur muret.

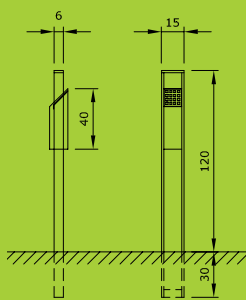

mod. 540V

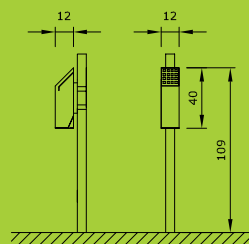

mod. 540M

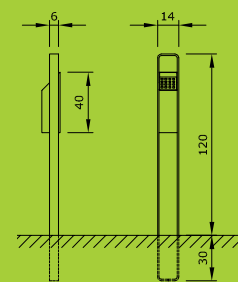

mod. 540VL

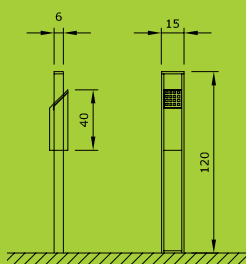

mod. 540B

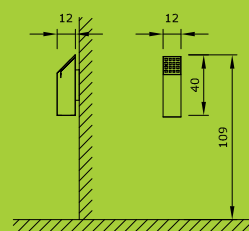

mod. 540W

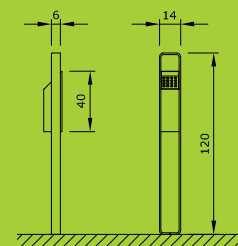

mod. 540BL

descrizione tecnica e disegni dwg | technische Beschreibung und dwg Zeichnungen | technical description and dwg drawings | description technique et dessins dwg: [www.euroform-w.com](http://www.euroform-w.com)

## lineafumo light

mod. 540VL, 540BL



Peso | Gewicht | Poids | Weight: 20 kg | 17 kg

**Gestell:** Flacheisen 15x60 mm (light: 10x60 mm), feuerverzinkt. **Korpus:** Stahlrohr 3 mm, feuerverzinkt. **Verriegelung:** mit Dreikantschlüssel, selbstschliessend. **Pulverbeschichtung:** RAL-Farben nach Wahl. **Befestigung:** zum Einbetonieren, zum Aufschrauben oder zum freien Aufstellen, Pfosten- und Wandmontage.

**Frame:** flat bar 15x60 mm (light: 10x60 mm), hot-dip galvanized. **Container:** steel tubing 3 mm, hot-dip galvanized. **Closing:** triangular key, self-closing. **Powder coating:** RAL colour to choose. **Fixation:** fixed in the ground, surface mounting, free-standing, wall-mounting or postmounting.

# fumée

mod. 510V, 510B, 510M, 510W  
mod. 511V, 511B, 511M, 511W



Peso | Gewicht | Poids | Weight: 8,5 | 9,5 kg

**Telaio:** tubo tondo Ø30 mm zincato a fuoco. **Corpo:** tubo d'acciaio Ø120 mm, zincato a fuoco. **Serratura:** con chiave a triangolo, autochiudente. **Trattamento a polvere:** Colori RAL a scelta. **Fissaggio:** in calcestruzzo, su pavimento solido o per collocamento libero.

**Ossature:** tube rond Ø 30 mm, galvanisé à chaud. **Corps du cendrier:** tube rond Ø120 mm galvanisé à chaud. **Verrouillage:** Avec clé triangulaire – fermeture automatique. **Revêtement poudre polyester:** Coloris RAL au choix. **Scellement:** Dans le sol, en surface ou autostable.



**Gestell:** Rundrohr Ø30 mm, feuerverzinkt. **Korpus:** Rundrohr Ø120 mm, feuerverzinkt. **Verriegelung:** mit Dreikantschlüssel, selbstschliessend. **Pulverbeschichtung:** RAL-Farben nach Wahl. **Befestigung:** zum Einbetonieren, zum Aufschrauben oder zum freien Aufstellen.

**Frame:** tubular steel Ø30 mm, hot-dip galvanized. **Container:** tubular steel Ø120 mm, hot-dip galvanized. **Closing:** triangular key, self-closing. **Powder coating:** RAL colour to choose. **Fixation:** fixed in the ground, surface mounting, free-standing.

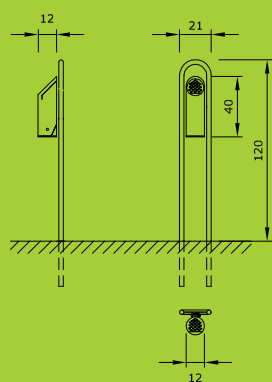

mod. 510V

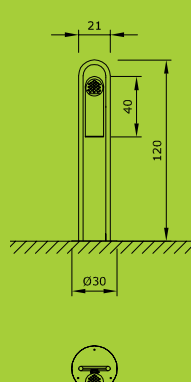

mod. 510B

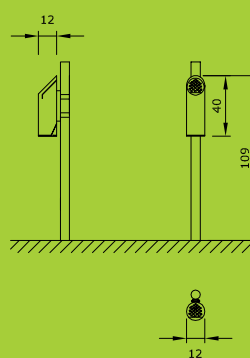

mod. 510M

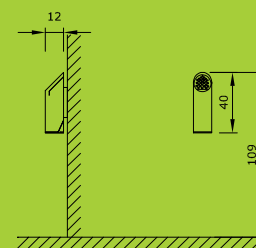

mod. 510W

descrizione tecnica e disegni dwg | technische Beschreibung und dwg Zeichnungen | technical description and dwg drawings | description technique et dessins dwg: [www.euroform-w.com](http://www.euroform-w.com)



Rail station, Tirano, Sondrio, Italy

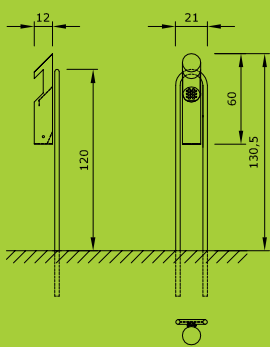

mod. 511V

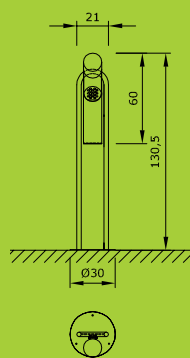

mod. 511B

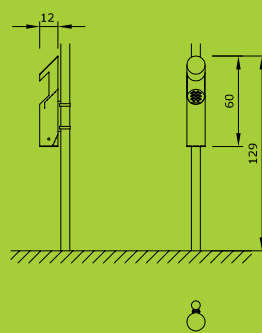

mod. 511M

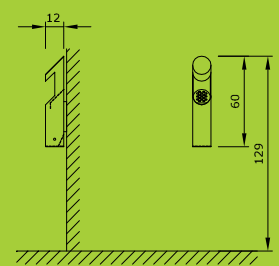

mod. 511W





# bike systems

portabiciclette | Fahrradssysteme | rangements pour cycles

Puliti, ordinati e compatti, questo sono le caratteristiche dei nostri sistemi di biciclette! Dal compatto portabiciclette singolo al elemento di sostegno fino alla panca-bici bilaterale con posizionamento della bici in alto e basso. Euroform w portabiciclette convivono attraverso un design senza tempo, durata e una percepita possibilità di parcheggiare la propria bici.

Sauber, aufgeräumt und platzsparend, dafür stehen unsere Fahrradssysteme! Vom kompakten Einzelständer über Anlehnbügel bis hin zur anspruchsvollen Fahrradbank mit beidseitiger Hoch-Tief-Stellung der Fahrräder. Euroform w Fahrradständer überzeugen durch ein zeitloses Design, Langlebigkeit und durch eine gut wahrnehmbare Fahrradabstellmöglichkeit.

Propre, ordonné et compact : ce sont les caractéristiques de nos systèmes pour vélos ! Du porte-vélos simple et compact à l'élément de soutien jusqu'au banc-vélos bilatéral avec positionnement du vélo en haut et en bas, les porte-vélos Euroform w sont convaincants grâce à un design classique, une longue durée et une possibilité perçue de stationner son vélo.

Clean, tidy and compact, this is what characterize our bicycle systems! From the compact single stand and the barrier to the bike-bench system with allows a bilateral high-low position of the bikes. Euroform w bicycle racks convince through a timeless design, durability and a good perceptible bike parking possibility.

## elegance

mod. 180G + 180A



Peso | Gewicht | Poids | Weight: 15 kg | 15 kg

## elegance

mod. 182G + 182E



Peso | Gewicht | Poids | Weight: 15 kg | 3 kg

## elegance

mod. 186G + 186E

ADFC  
proved



Peso | Gewicht | Poids | Weight: 16 kg | 3 kg

**Materiale:** tubo d'acciaio Ø30 e Ø25 mm zincato a fuoco.  
**Trattamento a polvere:** Colori RAL a scelta. **Fissaggio:** in calcestruzzo, su pavimento solido o per collocamento libero.

**Matériau:** tube d'acier Ø30 et Ø25 mm galvanisé à chaud.  
**Revêtement poudre polyester:** Coloris RAL au choix. **Scellement:** Dans le sol, en surface ou autostable.

**Material:** Stahlrohr Ø30 und Ø25 mm feuerverzinkt. **Pulverbeschichtung:** RAL-Farben nach Wahl. **Befestigung:** zum Einbetonieren, zum Aufschrauben oder zum freien Aufstellen.

**Material:** tubular steel Ø30 and Ø25 mm, hot-dip galvanized. **Powder coating:** RAL colour to choose. **Fixation:** fixed in the ground, surface mounting, free-standing.

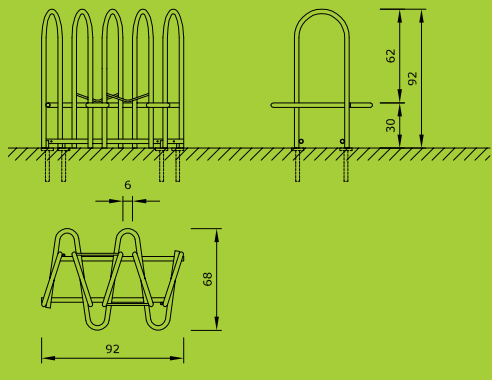

mod. 180G

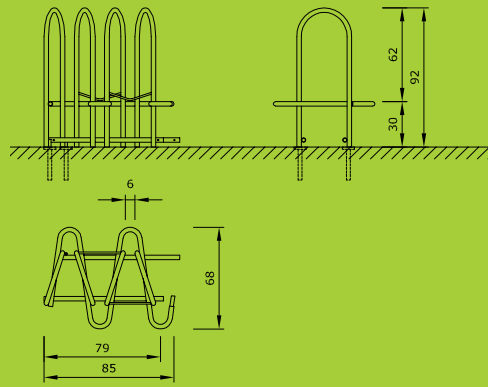

mod. 180A

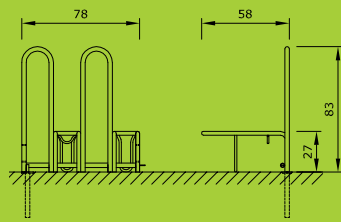

mod. 182G

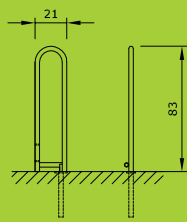

mod. 182E

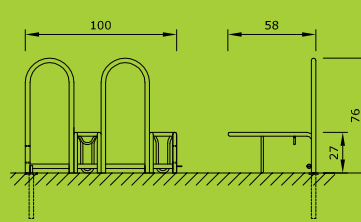

mod. 186G

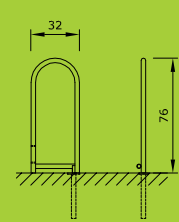

mod. 186E

descrizione tecnica e disegni dwg | technische Beschreibung und dwg Zeichnungen | technical description and dwg drawings | description technique et dessins dwg: [www.euroform-w.com](http://www.euroform-w.com)



Bressanone, Italy



Prato allo Stelvio, Italy

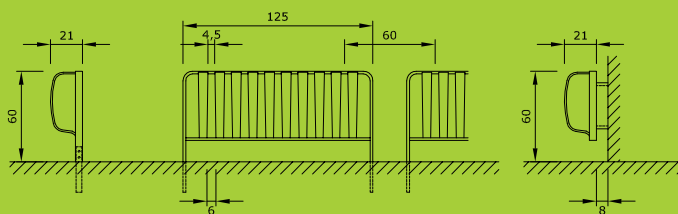

mod. 190

mod. 190W

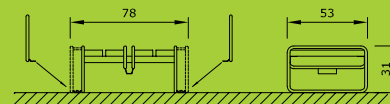

mod. 196

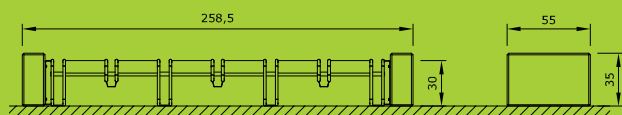

mod. 196L

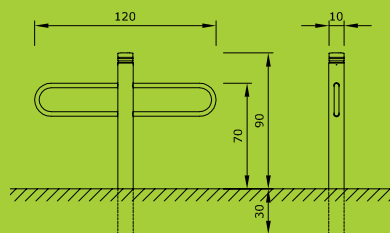

mod. 415

descrizione tecnica e disegni dwg | technische Beschreibung und dwg Zeichnungen | technical description and dwg drawings | description technique et dessins dwg: [www.euroform-w.com](http://www.euroform-w.com)





## basic

mod. 190, 190W



Peso | Gewicht | Poids | Weight: 14 kg

## basic

mod. 196



Peso | Gewicht | Poids | Weight: 12 kg

## basic

mod. 196L



Peso | Gewicht | Poids | Weight: 170 kg

## fritz

mod. 415



Peso | Gewicht | Poids | Weight: 25 kg

**BASIC 190: Telaio:** profilo a „U“ 45x18mm in lamiera decapata con collegamenti trasversali. **Lamelle:** 10 pezzi, coniche in lamiera decapata 1,5 mm zincate a fuoco e saldate sul telaio. **BASIC 196, 196L:** tubi tondi Ø18 mm e lamiera forata (mod. 196L). Tutto zincato a fuoco. Listelli in legno duro non trattati o trattati (mod. 196). **Posizionamento della biciclette in alto ed in basso.** Elementi laterali in calcestruzzo 55x35 cm (mod. 196L). **FRITZ: Telaio:** tubo d'acciaio Ø76 mm e Ø30 mm. **Copertura:** alluminio fusione in sabbia resistente alle acque saline.

**Trattamento a polvere:** colori RAL a scelta. **Fissaggio:** in calcestruzzo, su pavimento solido o per collocamento libero.

**BASIC 190: Ossature:** U profilé en acier embouti 45x18 mm, avec connexion croisée, galvanisée à chaud. **Lattes Réglage:** 10 pièces, coniquement pressés et tôle d'acier de 1,5 mm, galvanisé à chaud. **BASIC 196, 196L:** tubes d'acier Ø18 mm et tôle perforée (mod. 196L) galvanisée à chaud. Bois exotique, sans traitement de surface ou avec traitement (mod. 196). **Rangement alternatif haut/bas des vélos.** Eléments d'extrémité en béton 55x35 cm (mod. 196L). **FRITZ: Ossature:** tube rond Ø76 et Ø30 mm. **Cap:** aluminium sablé résistant à l'eau de mer.

**Revêtement poudre polyester:** Coloris RAL au choix. **Scellement:** Dans le sol, en surface ou autostable.

**BASIC 190: Rahmen:** U-förmig gepreßtem Stahlblech-Profil 45x18 mm, mit Querverbindung, feuerverzinkt. **Einstell-Lamellen:** 10 Stück, aus konisch gepreßtem und feuerverzinktem Stahlblech 1,5 mm. **BASIC 196, 196L:** gebogene Bügel aus Rundrohr Ø18 mm und Lochblech, feuerverzinkt (mod. 196L). Hartholzbohlen behandelt oder unbehandelt (mod. 196). **Hoch- und Tiefstellung der Fahrräder.** Seitenteile aus Beton 55x35 cm (mod. 196L). **FRITZ: Gestell:** Stahlrohr Ø76 mm und Ø30 mm. **Kappe:** seewasserbeständige Aluminiumsandgusslegierung. **Pulverbeschichtung:** RAL-Farben nach Wahl. **Befestigung:** zum Einbetonieren, zum Aufschrauben oder zum freien Aufstellen.

**BASIC 190: Frame:** U-shaped pressed steel sheet-profile 45 x 18 mm, with cross-connect, hot-dip galvanized. **Adjusting slats:** 10 pieces, conically pressed and galvanized steel sheet 1.5 mm. **BASIC 196, 196L:** round tubes Ø 18 mm and perforated plate (mod. 196L), hot-dip galvanized. Hard wooden slats treated or untreated (mod. 196). **Positioning of the bicycles in the top and bottom.** Side elements in concrete 55x35 cm (mod. 196L). **FRITZ: Frame:** round tube Ø76 mm and Ø30 mm. **Cover:** in aluminum alloy sand casting resistant against seawater.

**Powder coating:** RAL colour to choose. **Fixation:** fixed in the ground, surface mounting, free-standing.

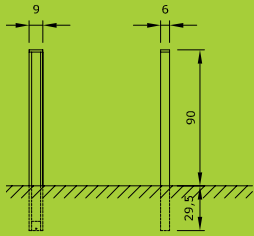

mod. 420N

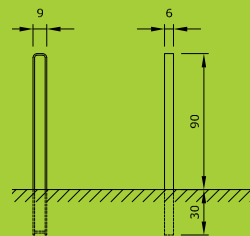

mod. 420LN

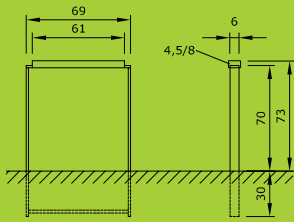

mod. 900

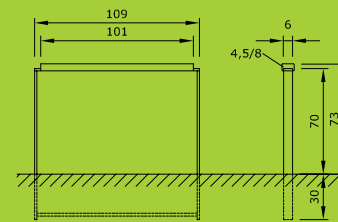

mod. 901

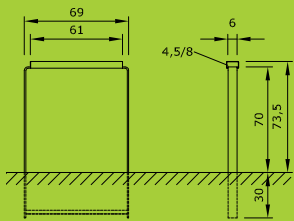

mod. 900L

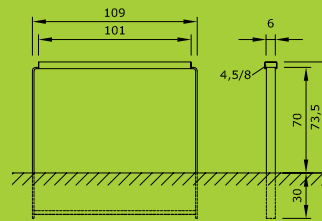

mod. 901L

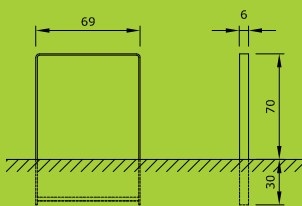

mod. 900ML

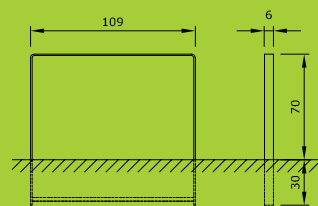

mod. 901ML

descrizione tecnica e disegni dwg | technische Beschreibung und dwg Zeichnungen | technical description and dwg drawings | description technique et dessins dwg: [www.euroform-w.com](http://www.euroform-w.com)



## lineapalo

mod. 420N

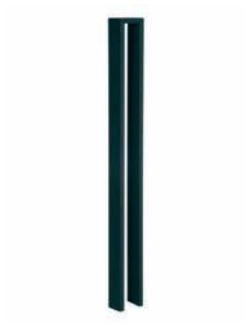

Peso | Gewicht | Poids | Weight: 18 kg

## lineapalo light

mod. 420LN



Peso | Gewicht | Poids | Weight: 12 kg

## lineasosta

mod. 900, 901



Peso | Gewicht | Poids | Weight: 24 | 28 kg

**LINEAPALO: Telaio:** ferro piatto 15x60 mm (light: 10x60 mm) zincato.

**LINEASOSTA: Telaio:** ferro piatto 15x60 mm zincato (light: 10x60 mm). **Seduta:** listello in legno duro non trattato o trattato. **Trattamento a polvere:** Colori RAL a scelta. **Fissaggio:** in calcestruzzo, su pavimento solido.

**LINEAPALO: Ossature:** Fer plat 15x60 mm (light: 10x60 mm), galvanisé.

**LINEASOSTA: Ossature:** Fer plat 15x60 mm, galvanisé (light: 10x60 mm). **Assise:** Latte en bois exotique sans traitement ou avec traitement de surface.

**Revêtement poudre polyester:** Coloris RAL au choix. **Scellement:** Dans le sol, en surface.

## lineasosta light

mod. 900L, 901L, 900ML, 901ML



Peso | Gewicht | Poids | Weight: 16 | 19 | 14 | 17 kg

**LINEAPALO: Gestell:** Flacheisen 15x60 mm (light: 10x60 mm), feuerverzinkt.

**LINEASOSTA: Gestell:** Flacheisen 15x60 mm, feuerverzinkt (light: 10x60 mm). **Sitzaufgabe:** Hartholzbohle unbehandelt oder behandelt. **Pulverbeschichtung:** RAL-Farben nach Wahl. **Befestigung:** zum Einbetonieren, zum Aufschrauben.

**LINEAPALO: Frame:** flat bar 15x60 mm (light: 10x60 mm), galvanized.

**LINEASOSTA: Frame:** flat bar 15x60 mm, galvanized (light: 10x60 mm). **Seating:** hard wooden slat untreated or treated. **Powder coating:** RAL colour to choose. **Fixation:** fixed in the ground, surface mounting.

## lineabici

mod. 188



Peso | Gewicht | Poids | Weight: 31 kg

## lineabici light

mod. 188L



Peso | Gewicht | Poids | Weight: 22 kg

## lock

mod. 460



Peso | Gewicht | Poids | Weight: 16 kg

**LINEABICI:** ferro piatto 15x60 mm (light 10x60 mm) zincato.  
**LOCK:** ferro piatto forato 60x10 mm, lamiera forata 3 mm zincato. **ARCO:** tubo tondo zincato a fuoco Ø60 mm.  
**Trattamento a polvere:** Colori RAL a scelta. **Fissaggio:** in calcestruzzo, su pavimento solido.

**LINEABICI:** Fer plat 15x60 mm (light 10x60 mm), galvanisé.  
**LOCK:** fer plat 60x10 mm, perforée metal 3 mm galvanisé.  
**ARCO:** tube d'acier Ø60 mm galvanisé à chaud.  
**Revêtement poudre polyester:** Coloris RAL au choix. **Scellement:** Dans le sol, en surface.

## arco

mod. 410N, 410B



Peso | Gewicht | Poids | Weight: 14 kg

**LINEABICI:** Flacheisen 15x60 mm (light 10x60 mm), verzinkt.  
**LOCK:** Flacheisen gelocht 60x10 mm, Lochblech 3 mm verzinkt.  
**ARCO:** feuerverzinktes Rundrohr Ø60 mm.  
**Pulverbeschichtung:** RAL-Farben nach Wahl. **Befestigung:** zum Einbetonieren, zum Aufschrauben.

**LINEABICI:** flat bar 15x60 mm (light 10x60 mm), galvanized.  
**LOCK:** flat bar perforated 60x10 mm, perforated metal 3 mm galvanized.  
**ARCO:** hot-dip galvanized round section pipe Ø60 mm.  
**Powder coating:** RAL colour to choose. **Fixation:** fixed in the ground, surface mounting.

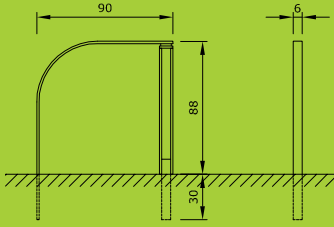

mod. 188

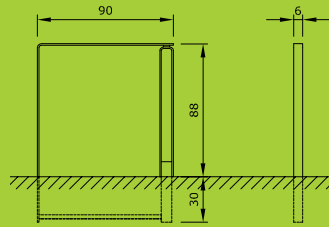

mod. 188L

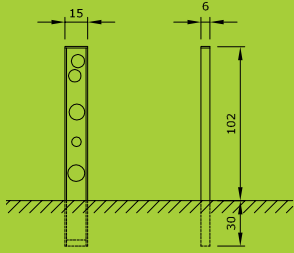

mod. 460

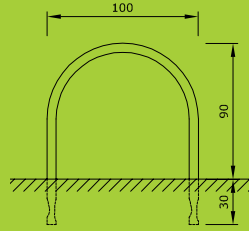

mod. 410N

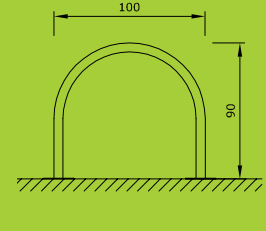

mod. 410B

descrizione tecnica e disegni dwg | technische Beschreibung und dwg Zeichnungen | technical description and dwg drawings | description technique et dessins dwg: [www.euroform-w.com](http://www.euroform-w.com)



Place of the City, Pfaffenhofen an der Ilm, Germany

## bike rail

mod. 4580



Peso | Gewicht | Poids | Weight: 25 kg

**BIKERAIL:** ferro piatto 8x10 mm, zincato a fuoco.  
**Trattamento a polvere:** Colori RAL a scelta. **Fissaggio:** in calcestruzzo, su pavimento solido o per collocamento libero.

**BIKERAIL:** fer plat 8x10 mm, galvanisé à chaud.  
**Revêtement poudre polyester:** Coloris RAL au choix. **Scellement:** Dans le sol, en surface ou autostable.

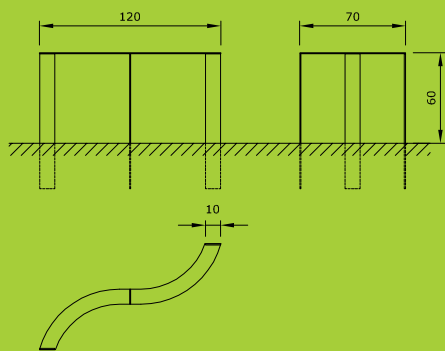

mod. 4580

## silhouette

mod. 185



Peso | Gewicht | Poids | Weight: 155 kg

**BIKERAIL:** Flacheisen 8x10 mm, feuerverzinkt.  
**Pulverbeschichtung:** RAL-Farben nach Wahl. **Befestigung:** zum Einbetonieren, zum Aufschrauben oder zum freien Aufstellen.

**BIKERAIL:** flat bar 8x10 mm, hot-dip galvanized.  
**Powder coating:** RAL colour to choose. **Fixation:** fixed in the ground, surface mounting, free-standing.

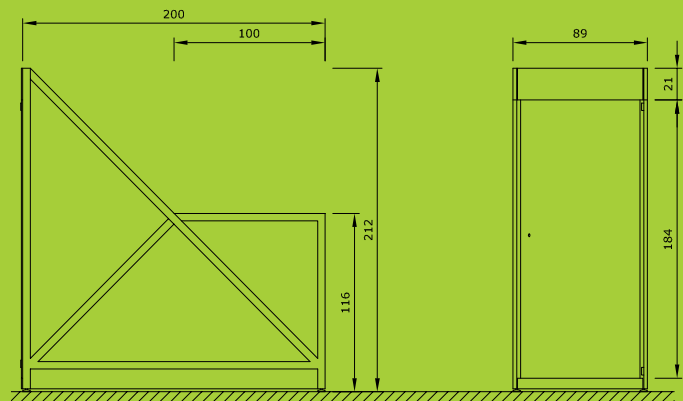

mod. 185

descrizione tecnica e disegni dwg | technische Beschreibung und dwg Zeichnungen | technical description and dwg drawings | description technique et dessins dwg: [www.euroform-w.com](http://www.euroform-w.com)



**SILHOUETTE:** Rahmen aus speziellen Stahlprofilen. Füllungen der Seitenpaneele wahlweise aus Streckmetall oder geschlossenem Stahlblech. Türen mit oder ohne Gepäckablage aus Stahlblech oder verzinktem Blech. Alle Schraubenverbindungen aus Edelstahl. Oberflächenbehandlung: Stahlprofile, Streckmetall und Stahlblech sind feuerverzinkt. Pulverbeschichtung in RAL 7016 anthrazitgrau. Alle anderen RAL-Farben auf Anfrage möglich. Fixierung: auf bauseits vorbereiteten und nivellierten Streifenfundamenten oder zum Aufstellen mit Stellfüßen. Optimaler Diebstahl- und Vandalismusschutz als auch die Möglichkeit zum Verstauen von Taschen, Jacken o.ä.

**SILHOUETTE:** Cadre fait de profils en acier spécial. Panneaux latéraux disponibles soit en métal déployé soit en tôle pleine. Portes avec ou sans coffre en tôle décapée ou galvanisée. Toute la visserie en acier inox. Traitement de surface : profils, tôle déployée et décapée galvanisés à chaud. Traitement par poudrage dans la couleur RAL 7016 gris anthracite ou toute autre couleur RAL sur demande. Fixation : sur des fondations nivelées avec des pieds réglables. Elle offre aussi bien une protection optimale contre les vols et les vandalismes que la possibilité de déposer sacs, vestes et autre.

**SILHOUETTE:** Cornice in profili d'acciaio speciali. Pannelli laterali disponibili o in lamiera stirata o in lamiera piena. Porte con o senza bagagliaio in lamiera decapata o zincata. Tutta la viteria in acciaio inox. Trattamento superficiale: profili, lamiera stirata e decapata zincati a fuoco. Trattamento a polvere nel colore RAL 7016 grigio antracite o ogni altro colore RAL su richiesta. Fissaggio: su fondamenta livellati con piedini regolabili. Offre sia una protezione ottimale da furti e vandalismi che la possibilità di depositare borse, giacche ed altro.

**SILHOUETTE:** Frame: steel sections, with either expanded metal or galvanized steel sheet walls. Doors: either from steel sheet or galvanized sheeting. Surface treatment: steel sections, expanded metal and steel sheeting are hot-dip galvanized. Powdercoating in RAL7016 grey anthracite or any other RAL colours are available upon request. Fixation: mounting on strip foundations or free standing with adjustable feet. Offers both optimum protection against theft and vandalism as well as the possibility of storing bags, coats etc.









# locking systems

sistemi di sbarramento | absperssysteme | barrières

Decorativi e caratterizzanti - le colonnine di sbarramento euroform w sono moderne e senza tempo per forma e colore, ma dalla struttura robusta e vivace. Ne esistono versioni con diversi diametri e, su richiesta, con diversi cappellotti.

Dekorativ markierend - Absperssysteme von euroform w sind zeitlos modern in Form und Farbe, dabei aber robust und langlebig in der Konstruktion. Es gib runde und eckige Ausführungen. Auf Wunsch filigran mit diversen Köpfen versehen.

Décoratifs et caractéristiques, les colonnes de fermeture Euroform w modernes et classiques pour leur forme et couleur et à la structure robuste et vive. Il existe des versions avec différents diamètres et, sur demande, avec différents bouchons.

Decorative and distinctive "euroform w" bollards are both timelessly modern in design and colour, any yet robust and durable in their construction. There are round and angular versions. If required, they can be provided with diverse covers as well.

## lineabarriera

mod. 910



Peso | Gewicht | Poids | Weight: 32 kg

## lineabarriera light

mod. 910L



Peso | Gewicht | Poids | Weight: 22 kg

## lineapalo

mod. 420N



Peso | Gewicht | Poids | Weight: 18 kg

**LINEABARRIERA: Materiale:** ferro piatto 15x60 mm (light: 10x60 mm) e tondino di ferro Ø18 mm zincato. **LINEAPALO: Telaio:** ferro piatto 15x60 mm (light: 10x60 mm) zincato. **Trattamento a polvere:** Colori RAL a scelta. **Fissaggio:** in calcestruzzo, su pavimento solido.

**LINEABARRIERA: Matériaux:** fer plat 15x60 mm (light: 10x60 mm) et fer rond Ø18 mm, galvanisé.

**LINEAPALO: Matériaux:** Fer plat 15x60 mm (light: 10x60 mm), galvanisé.

**Revêtement poudre polyester:** Coloris RAL au choix. **Scellement:** Dans le sol, en surface.

## lineapalo light

mod. 420N/L



Peso | Gewicht | Poids | Weight: 12 kg

**LINEABARRIERA: Material:** Flacheisen 15x60 mm (light: 10x60 mm) und Rundeisen Ø18 mm, verzinkt.

**LINEAPALO: Material:** Flacheisen 15x60 mm (light: 10x60 mm), verzinkt.

**Pulverbeschichtung:** RAL-Farben nach Wahl. **Befestigung:** zum Einbetonieren, zum Aufschrauben.

**LINEABARRIERA: Material:** flat bar 15x60 mm (light: 10x60 mm) and rounded steel Ø18 mm, galvanized.

**LINEAPALO: Material:** flat bar 15x60 mm (light: 10x60 mm), galvanized.

**Powder coating:** RAL colour to choose. **Fixation:** fixed in the ground, surface mounting.

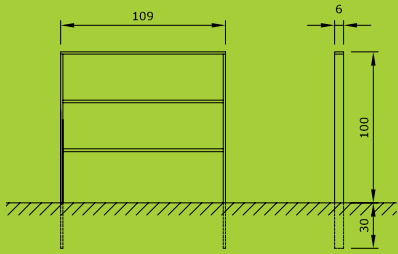

mod. 910

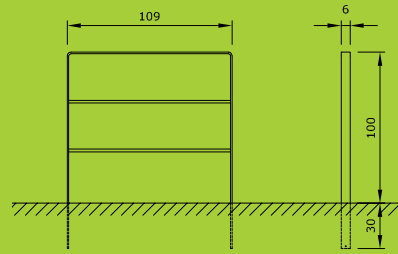

mod. 910L

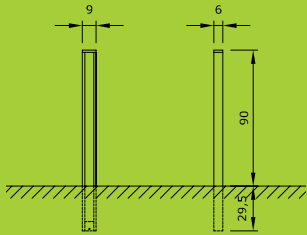

mod. 420N

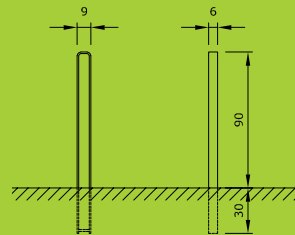

mod. 420N/L

descrizione tecnica e disegni dwg | technische Beschreibung und dwg Zeichnungen | technical description and dwg drawings | description technique et dessins dwg: [www.euroform-w.com](http://www.euroform-w.com)



Campo Tures, Bolzano, Italy

## lineasosta

mod. 900, 901



Peso | Gewicht | Poids | Weight: 24 kg | 28 kg

## lineasosta light

mod. 900L, 901L, 900ML, 901ML



Peso | Gewicht | Poids | Weight: kg

## linealuce

mod. 425N



Peso | Gewicht | Poids | Weight: 23 kg

**LINEASOSTA:** ferro piatto 15x60 mm (light: 10x60 mm) zincato. **Seduta:** listello in legno duro mm non trattato e trattato. **LINEALUCE:** tubo quadro 110x110 mm zincato a fuoco. **Dati tecnici illuminazione:** modulo LED con grado di protezione ISO IP 65, tensione: 95 – 260V, potenza: 1W, durata di vita: > 50.000 ore, colore: bianco. **LOCK:** ferro piatto forato 60x10 mm, lamiera forata 3 mm zincato. **Trattamento a polvere:** Colori RAL a scelta. **Fissaggio:** in calcestruzzo, su pavimento solido.

**LINEASOSTA:** fer plat 15x60 mm (light: 10x60 mm), galvanisé. **Assise:** Latte en bois exotique sans traitement ou avec traitement de surface. **LINEALUCE:** tube carré 110x110 mm, galvanisé à chaud. **Détails Techniques pour l'éclairage:** 3 LED-Modul, ISO Protection IP 65, Voltage: 95 – 260V, Puissance totale: 3W. **Durée de vie:** > 50.000 h, Coloris: blanc. **LOCK:** fer plat 60x10 mm, perforée metal 3 mm galvanisé. **Revêtement poudre polyester:** Coloris RAL au choix. **Scellement:** Dans le sol, en surface.

## lock

mod. 460



Peso | Gewicht | Poids | Weight: 16 kg

**LINEASOSTA:** Flacheisen 15x60 mm (light: 10x60 mm), verzinkt. **Sitzauflage:** Hartholzbohle unbehandelt oder behandelt. **LINEALUCE:** Vierkantrohr 110x110 mm, feuerverzinkt. **Technische Daten für die Beleuchtung:** LED Modul, ISO Schutzart IP 65, Spannung: 95 – 260V, Leistung: 1W, Lebensdauer: > 50.000 h, Lichtfarbe: weiß. **LOCK:** Flacheisen gelocht 60x10 mm, Lochblech 3 mm verzinkt. **Pulverbeschichtung:** RAL-Farben nach Wahl. **Befestigung:** zum Einbetonieren, zum Aufschrauben.

**LINEASOSTA:** flat bar 15x60 mm (light: 10x60 mm), galvanized. **Seating:** hard wooden slat untreated or treated. **LINEALUCE:** square tube 110x110 mm, hot-dip galvanized. **Technical data for illumination:** LED, ISO ingress protection IP 65. Operation voltage: 95 – 260V. Power consumption: 1W. Life time: > 50.000 h. Colour: white. Lateral covers in plexiglass. **LOCK:** flat bar perforated 60x10 mm, perforated metal 3 mm galvanized. **Powder coating:** RAL colour to choose. **Fixation:** fixed in the ground, surface mounting.

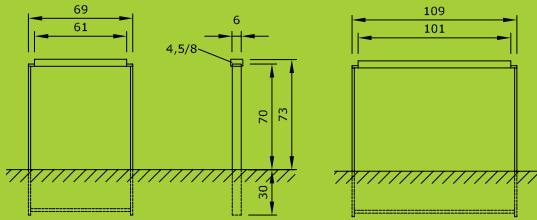

mod. 900

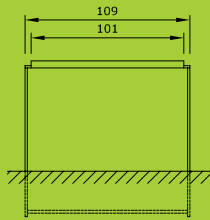

mod. 901

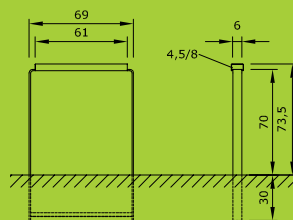

mod. 900L

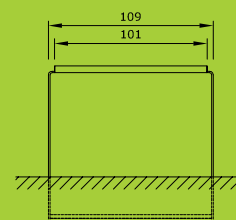

mod. 901L

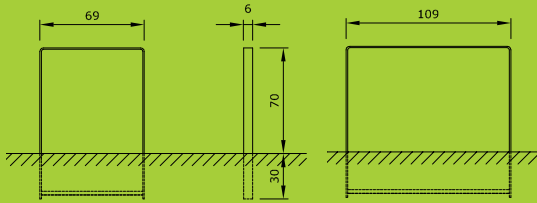

mod. 900ML

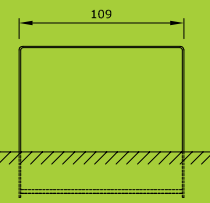

mod. 901ML

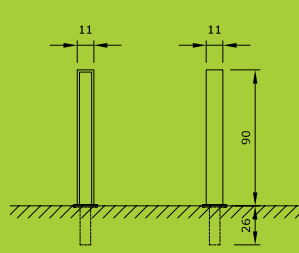

mod. 425N

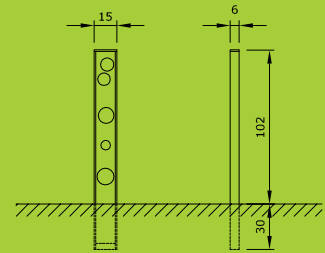

mod. 460

descrizione tecnica e disegni dwg | technische Beschreibung und dwg Zeichnungen | technical description and dwg drawings | description technique et dessins dwg: [www.euroform-w.com](http://www.euroform-w.com)



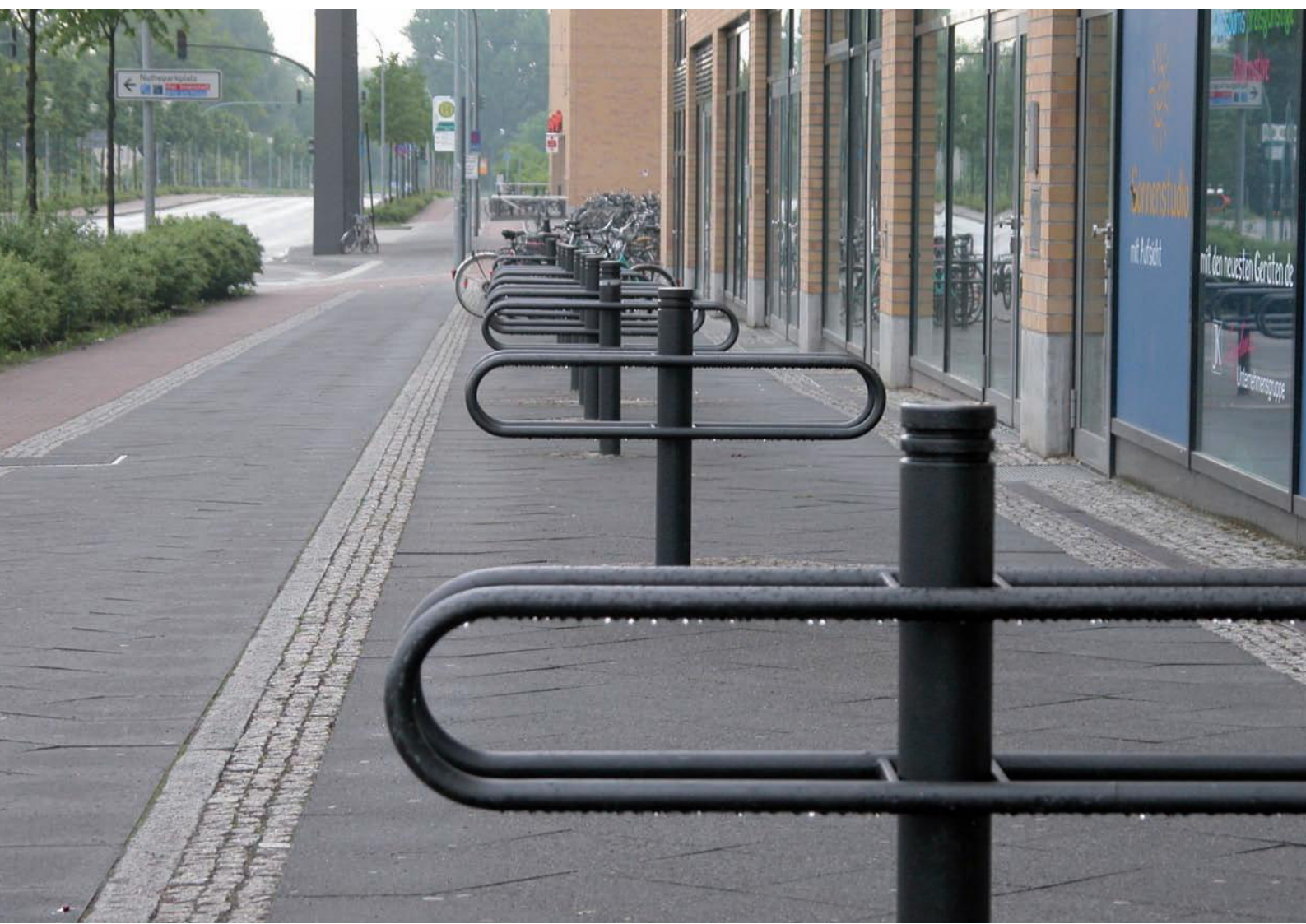



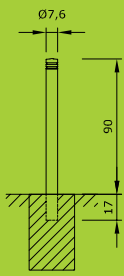

mod. 402N/FR

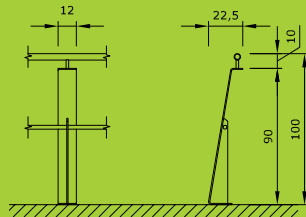

mod. 1490

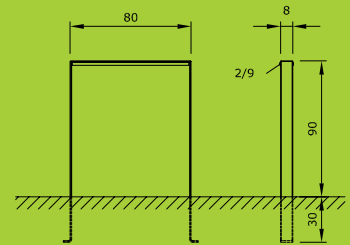

mod. 950

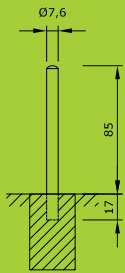

mod. 402N

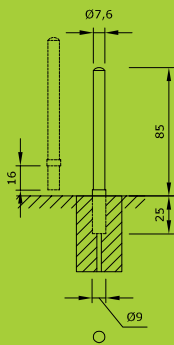

mod. 402H

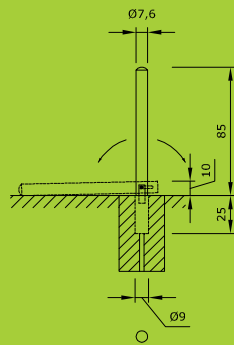

mod. 402K



mod. 403N



N = fisso | fest | fixe | fixed



K = ribaltabile | kippbar | rabattabile | collapsible



H = estraibile | herausnehmbar | amovible | estraible



aron - mod. 950

descrizione tecnica e disegni dwg | technische Beschreibung und dwg Zeichnungen | technical description and dwg drawings | description technique et dessins dwg: [www.euroform-w.com](http://www.euroform-w.com)





## fritz

mod. 402N/FR, H/FR, K/FR



Peso | Gewicht | Poids | Weight: 6 kg

## barrier

mod. 402N, 402H, 402K  
mod. 403N, 403H, 403K



Peso | Gewicht | Poids | Weight: 6 - 14 kg  
Peso | Gewicht | Poids | Weight: 10 - 14,5 kg

**FRITZ:** tubo tondo d'acciaio Ø76 mm zincato a fuoco. **Copertura:** alluminio fusione in sabbia resistente alle acque saline. **ZETABARRIERA:** ferro piatto 8x120 mm, tubo tondo Ø42 mm, tubo tondo Ø25 mm, zincato a fuoco. **BARRIER 402:** tubo tondo d'acciaio Ø76 mm zincato a fuoco. **BARRIER 403:** tubo tondo d'acciaio Ø121 mm zincato a fuoco. **ARON:** ferro piatto 10x80 mm zincato a fuoco, con listello in legno duro non trattato o trattato, bordo smussato. **Trattamento a polvere:** colori RAL a scelta. **Fissaggio:** in calcestruzzo, su pavimento solido.

**FRITZ:** tube rond Ø76 mm galvanisé à chaud. **Cap:** aluminium sablé résistant à l'eau de mer. **ZETABARRIERA:** fer plat 8x120 mm, tube rond 42x2 mm, tube rond Ø25 mm, galvanisé à chaud. **BARRIER 402:** tube rond Ø76 mm galvanisé à chaud. **BARRIER 403:** tube rond Ø121 mm galvanisé à chaud. **ARON:** fer plat 10x80 mm, galvanisé à chaud, avec latte en bois exotique sans ou avec traitement de surface, bord biseauté. **Revêtement poudre polyester:** coloris RAL au choix. **Scellement:** dans le sol, en surface.

## zeta barriera

mod. 1490



## aron

mod. 950



Peso | Gewicht | Poids | Weight: 22 kg

**FRITZ:** Rundstahlrohr Ø76 mm feuerverzinkt. **Kappe:** see-wasserbeständige Aluminiumsandgusslegierung. **ZETABARRIERA:** Flacheisen 8x120 mm, Rundrohr Ø42 mm, Rundrohr Ø25 mm, feuerverzinkt. **BARRIER 402:** Rundstahlrohr Ø76 mm feuerverzinkt. **BARRIER 403:** Rundstahlrohr Ø121 mm feuerverzinkt. **ARON:** Flacheisen 10x80 mm, feuerverzinkt, mit Hartholzbohle unbehandelt oder behandelt, gefaste Kante. **Pulverbeschichtung:** RAL-Farben nach Wahl. **Befestigung:** zum Einbetonieren, zum Aufschrauben.

**FRITZ:** round tubular Ø76 mm hot-dip galvanized. **Cover:** in aluminum alloy sand casting resistant against seawater. **ZETABARRIERA:** flat bar 8x120 mm, tube Ø42 mm, round tube Ø25 mm, hot-dip galvanized. **BARRIER 402:** round tubular steel Ø76 mm hot-dip galvanized. **BARRIER 403:** round tubular steel Ø121 mm hot-dip galvanized. **ARON:** flat bar 10x80 mm, hot-dip galvanized, with hard wooden slat untreated or treated, bevelled edge. **Powder coating:** RAL colour to choose. **Fixation:** fixed in the ground, surface mounting.



Stade Marcel Bec, Meudon, France

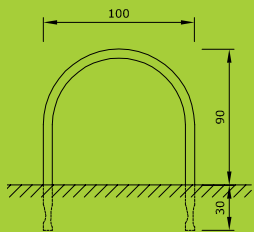

mod. 410N

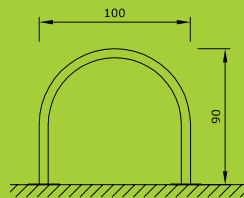

mod. 410B

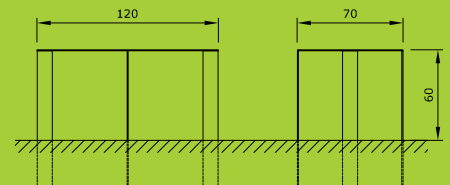

mod. 4580

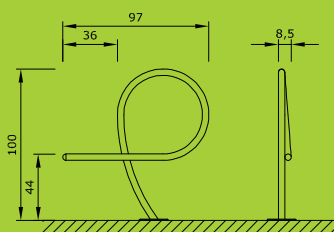

mod. 4550

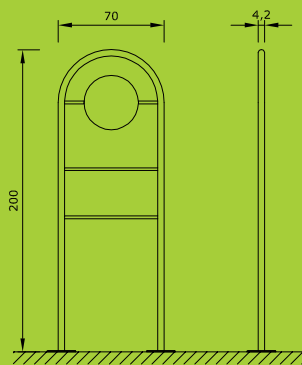

mod. 4555

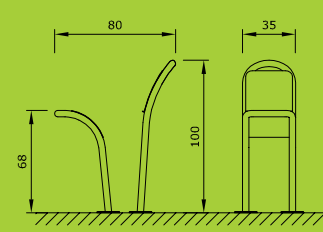

mod. 4560

descrizione tecnica e disegni dwg | technische Beschreibung und dwg Zeichnungen | technical description and dwg drawings | description technique et dessins dwg: [www.euroform-w.com](http://www.euroform-w.com)

## arco

mod. 410N, 410B



Peso | Gewicht | Poids | Weight: 14 kg

## bike rail

mod. 4580



Peso | Gewicht | Poids | Weight: 25 kg

## nove

mod. 4550

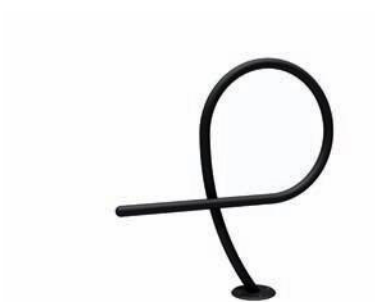

Peso | Gewicht | Poids | Weight: 10 kg

## tube, sittube

mod. 4555, 4560



Peso | Gewicht | Poids | Weight: 21 kg | 23 kg

**ARCO:** tubo tondo zincato a fuoco Ø60 mm.  
**BIKERAIL:** ferro piatto 8x10 mm, zincato a fuoco.  
**NOVE/TUBE/SITTUBE:** tubo tondo Ø42 mm, zincato a fuoco. **Trattamento a polvere:** Colori RAL a scelta. **Fissaggio:** in calcestruzzo, su pavimento solido.

**ARCO:** tube d'acier Ø60 mm galvanisé à chaud.  
**BIKERAIL:** fer plat 8x10 mm, galvanisé à chaud.  
**NOVE/TUBE/SITTUBE:** fer plat Ø42 mm, galvanisé à chaud.  
**Revêtement poudre polyester:** Coloris RAL au choix. **Scellement:** Dans le sol, en surface.

**ARCO:** feuerverzinktes Rundrohr Ø60 mm.  
**BIKERAIL:** Flacheisen 8x10 mm, feuerverzinkt.  
**NOVE/TUBE/SITTUBE:** Rundrohr Ø42 mm, feuerverzinkt.  
**Pulverbeschichtung:** RAL-Farben nach Wahl. **Befestigung:** zum Einbetonieren, zum Aufschrauben.

**ARCO:** hot-dip galvanized round section pipe Ø60 mm.  
**BIKERAIL:** flat bar 8x10 mm, hot-dip galvanized.  
**NOVE/TUBE/SITTUBE:** tubular steel Ø42 mm, hot-dip galvanized. **Powder coating:** RAL colour to choose. **Fixation:** fixed in the ground, surface mounting.





# notice boards

bacheche | anschlagtafeln | panneau d'affichage

Le bacheche servono a fornire informazioni e scambiarsi comunicazioni. Le nostre bacheche hanno le dimensioni e le forme più svariate, a prescindere che vengano installate presso una fermata d'autobus o in un'altra postazione. Siamo in grado di soddisfare qualsiasi esigenza!

Anschlagtafeln dienen zur Information und zum Austausch von Mitteilungen. Egal ob an Bushaltestellen oder frei aufgestellt, unsere Anschlagtafeln können in verschiedenen Grössen und Formen hergestellt werden. Individuellen Sonderwünschen sind dabei keine Grenzen gesetzt.

Les tableaux servent à fournir des informations et à échanger des communications. Nos tableaux ont les dimensions et les formes les plus variées, qu'ils soient installés près d'un arrêt de bus ou dans un autre emplacement. Nous sommes en mesure de satisfaire toutes les exigences !

The message boards are used to provide information and exchange communications. Our message boards come in different size and the most varied forms, whether they are installed at a bus stop or in another location. We can satisfy all needs!

## lineaspot

mod. 915



Peso | Gewicht | Poids | Weight: 29 kg

## lineabacheca

mod. 930



Peso | Gewicht | Poids | Weight: 84 kg

## lineaspot light

mod. 915L



Peso | Gewicht | Poids | Weight: 32 kg

## infopoint

mod. 4430, 4435

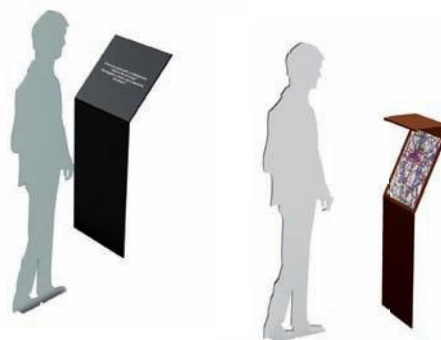

Peso | Gewicht | Poids | Weight: 35 | 36 kg

**LINEASPOT:** ferro piatto 15x60 mm (light: 10x60 mm) zincato. **Riempimento:** in lamiera d'acciaio zincato spess. 2 mm.

**LINEABACHECA:** ferro piatto 10x100 mm e in lamiera d'acciaio spess. 2 mm, zincato. **Vetrina:** vetro-ESG 6 mm.

**INFOPOINT:** in lamiera d'acciaio spess. 6 mm, zincato. **Trattamento a polvere:** Colori RAL a scelta. **Fissaggio:** in calcestruzzo, su pavimento solido.

**LINEASPOT:** fer plat 15x60 mm (light: 10x60 mm), galvanisé. **Remplissage:** Tôle d'acier 2 mm, galvanisé.

**LINEABACHECA:** fer plat 10x100 mm et acier épaisseur 2 mm, galvanisé. **Vitrine:** Vitre-ESG 6 mm.

**INFOPOINT:** fer plat 6 mm, galvanisé.

**Revêtement poudre polyester:** Coloris RAL au choix. **Scellement:** Dans le sol, en surface.

**LINEASPOT:** Flacheisen 15x60 mm (light: 10x60 mm), verzinkt. **Füllung:** Stahlblech 2 mm, verzinkt.

**LINEABACHECA:** Flacheisen 10x100 mm und Stahlblech 2 mm, verzinkt. **Vitrine:** aus ESG-Glas 6 mm.

**INFOPOINT:** Stahlblech 6 mm, verzinkt. **Pulverbeschichtung:** RAL-Farben nach Wahl. **Befestigung:** zum Einbetonieren, zum Aufschrauben.

**LINEASPOT:** Flat bar 15x60 mm (light: 10x60 mm), galvanized. **Filling:** 2 mm metal sheet, galvanized.

**LINEABACHECA:** flat iron 10x100 mm and steel sheet thickness 2 mm, galvanized. **Glazing:** single-sheet safety glass thickness 6 mm.

**INFOPOINT:** galvanized steel plat, 6 mm thick.

**Powder coating:** RAL colour to choose. **Fixation:** fixed in the ground, surface mounting.

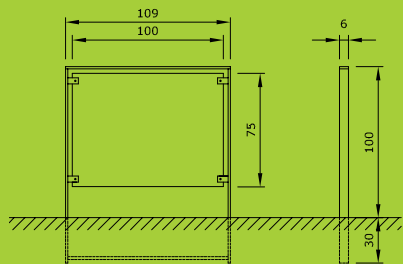

mod. 915

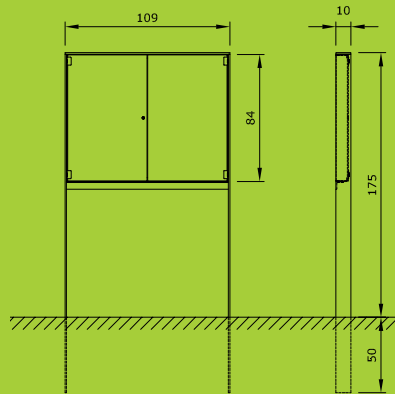

mod. 930

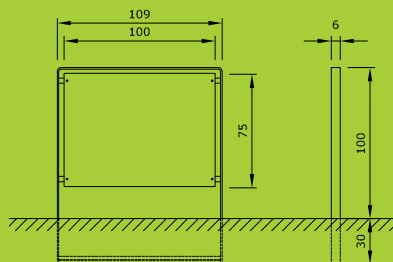

mod. 915L

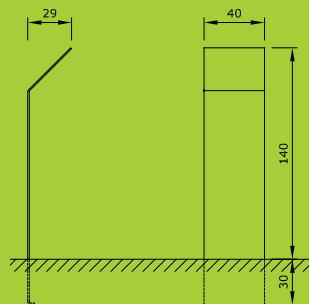

mod. 4430

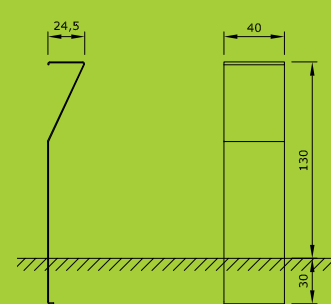

mod. 4435

descrizione tecnica e disegni dwg | technische Beschreibung und dwg Zeichnungen | technical description and dwg drawings | description technique et dessins dwg: [www.euroform-w.com](http://www.euroform-w.com)



Historical Center, Asolo, TV

# flamingo

mod. 4570



Peso | Gewicht | Poids | Weight: 12 kg

Lamiera d'acciaio spessore 3 mm, zincato a fuoco. **Trattamento a polvere:** Colori RAL a scelta. **Fissaggio:** in calcestruzzo, contro muro.

Acier 3 mm, galvanisé à chaud. **Revêtement poudre polyester:** Coloris RAL au choix. **Scellement:** Dans le sol, fixation murale.

Stahlblech 3 mm, feuerverzinkt. **Pulverbeschichtung:** RAL-Farben nach Wahl. **Befestigung:** zum Einbetonieren, Mauermontage.

Steel sheet 3 mm, hot-dip galvanized. **Powder coating:** RAL colour to choose. **Fixation:** fixed in the ground, wall mounting.

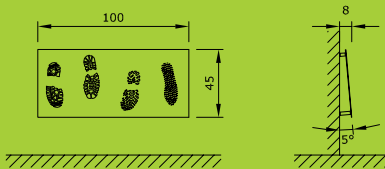

mod. 4570

descrizione tecnica e disegni dwg | technische Beschreibung und dwg Zeichnungen | technical description and dwg drawings | description technique et dessins dwg: [www.euroform-w.com](http://www.euroform-w.com)





MUNICIPIO





# plant systems

fioriere | bepflanzungssysteme | jardinières

euroform w offre numerose e diverse soluzioni per l'inverdimento, dalle forme e dimensioni più svariate. I materiali disponibili – legno e metallo – si possono combinare secondo le esigenze individuali. Grazie alle soluzioni da noi proposte è possibile conferire una piacevole nota “verde” agli ambienti urbani.

euroform w bietet eine Vielzahl an verschiedenen Bepflanzungssystemen an. Dabei ist Form oder Grösse keine Grenze gesetzt. Die Auswahl des Materials, Holz oder Metall, kann dabei individuell kombiniert werden. Durch unsere Bepflanzungssysteme können im innerstädtischen Bereich schöne „grüne Akzente“ gesetzt werden.

Euroform w offre de nombreuses solutions différentes pour la mise au vert, présentant les formes et les dimensions les plus différentes. Les matériaux disponibles, bois et métal, peuvent s'associer selon les exigences individuelles. Grâce à nos solutions, il est possible de donner une note « verte » agréable aux environnements urbains.

euroform w offers many different solutions for greening of various shapes and sizes. The available materials – wood and metal – can be combined according to individual needs. Thanks to our solutions, you can add a pleasant “green” touch to urban environments.

## lineafiore

mod. 175I, 175II



Peso | Gewicht | Poids | Weight: 30 kg | 55 kg

## lineafiore light

mod. 175I/L, 175II/L



Peso | Gewicht | Poids | Weight: 26 kg | 49 kg

## lineafiore

mod. 177



Peso | Gewicht | Poids | Weight: 178 kg

**LINEAFIORE 175: Vasca:** lamiera d'acciaio spess. 2 mm (mod. 175L = 1,5 mm), zincata. **Rivestimento:** listelli in legno duro non trattati o trattati.

**LINEAFIORE 177: Rivestimento:** lamiera d'acciaio 6 mm. **Bordatura in alto (mod. 177):** ferro piatto 80x8 mm. **Vasca:** lamiera d'acciaio 2, 5 mm, zincato a fuoco. **Trattamento a polvere:** Colori RAL a scelta.

**LINEAFIORE 175: Corps:** Tôle d'acier 2 mm (mod. 175L = 1,5 mm), galvanisé. **Habillage:** Lattes en bois exotique sans ou avec traitement.

**LINEAFIORE 177: Habillage:** acier 6 mm. **Rebord sur la partie haute (mod. 177L):** fer plat 80x8 mm. **Vasque:** acier 2, 5 mm, galvanisé à chaud. **Revêtement poudre polyester:** Coloris RAL au choix.

## lineafiore light

mod. 177L



Peso | Gewicht | Poids | Weight: 158 kg

**LINEAFIORE 175: Behälter:** Stahlblech 2 mm (mod. 175L = 1,5 mm), verzinkt. **Ummantelung:** Hartholzbohlen 30x59 mm, behandelt oder unbehandelt. **LINEAFIORE 177: Ummantelung:** Stahlblech 6 mm.

**Einrahmung oben (mod. 177):** Flacheisen 80x8 mm. **Bodentasse:** 2,5 mm, feuerverzinkt. **Pulverbeschichtung:** RAL-Farben nach Wahl.

**LINEAFIORE 175: Reservoir:** 2 mm (mod. 175L = 1,5 mm) metal sheet, galvanized. **Panelling:** Hard wooden slats, untreated or treated.

**LINEAFIORE 177: Facing:** steel sheet 6 mm. **High edges (mod. 177L):** flat iron 80x8 mm. **Tank:** metal sheet 2,5 mm, hot-dip galvanized. **Powder coating:** RAL colour to choose.

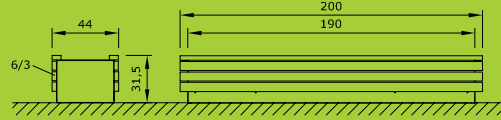
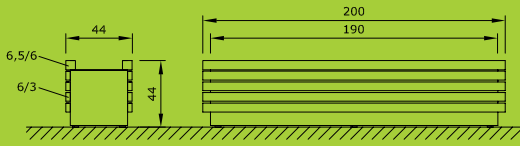
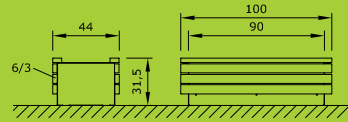
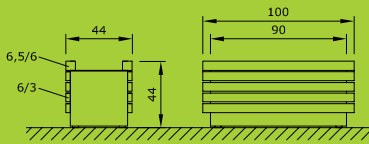

mod. 175I | 175II

mod. 175I/L | 175II/L

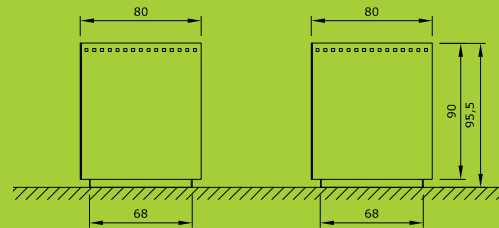
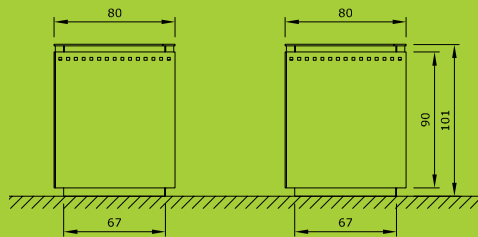

mod. 177

mod. 177L

descrizione tecnica e disegni dwg | technische Beschreibung und dwg Zeichnungen | technical description and dwg drawings | description technique et dessins dwg: [www.euroform-w.com](http://www.euroform-w.com)

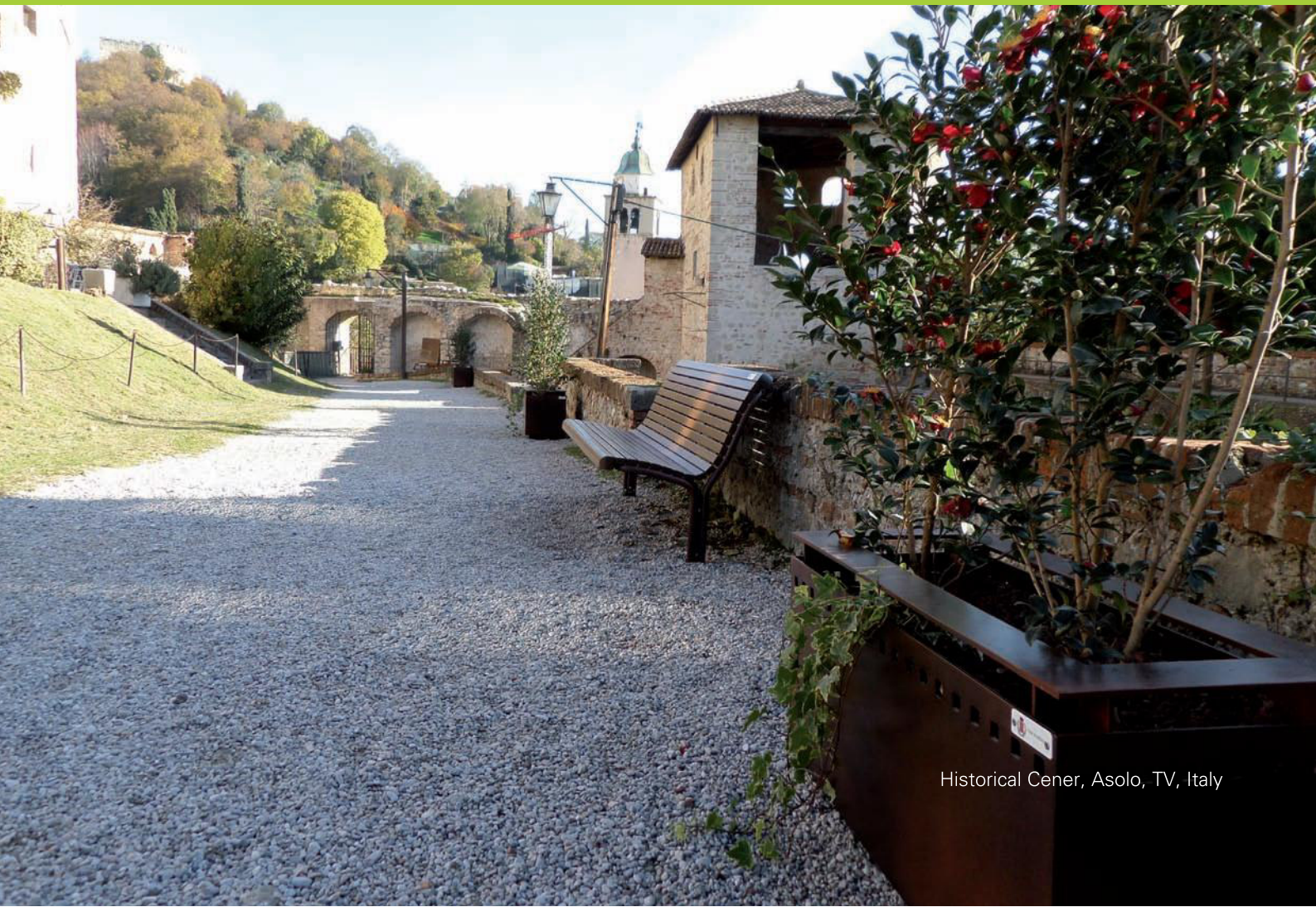

Historical Cener, Asolo, TV, Italy

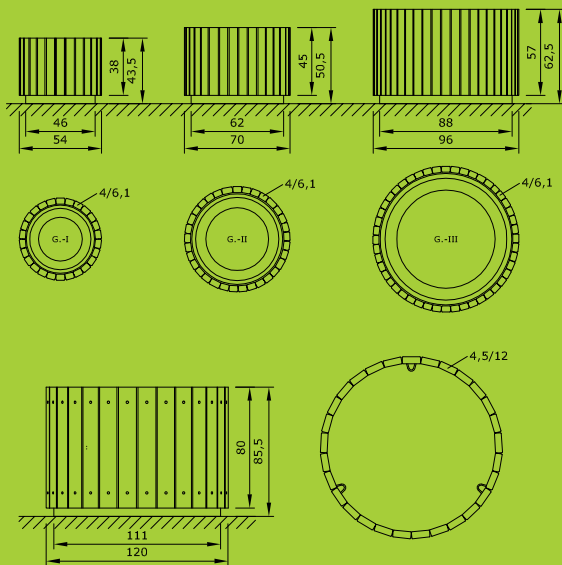

mod. 130I | 130II | 130III | 130VI

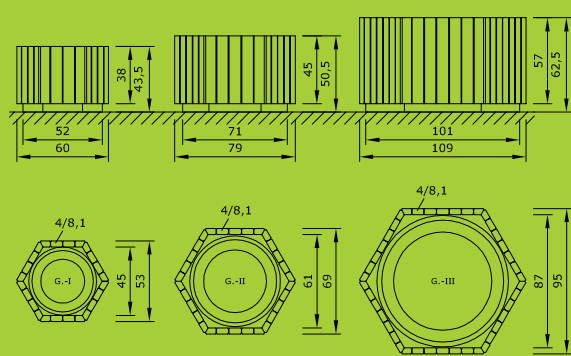

mod. 140I | 140II | 140III

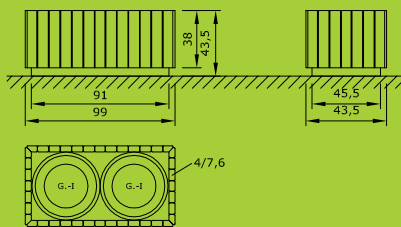

mod. 170I

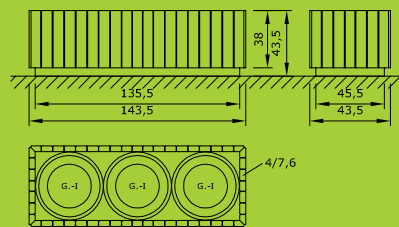

mod. 170II

descrizione tecnica e disegni dwg | technische Beschreibung und dwg Zeichnungen | technical description and dwg drawings | description technique et dessins dwg: [www.euroform-w.com](http://www.euroform-w.com)

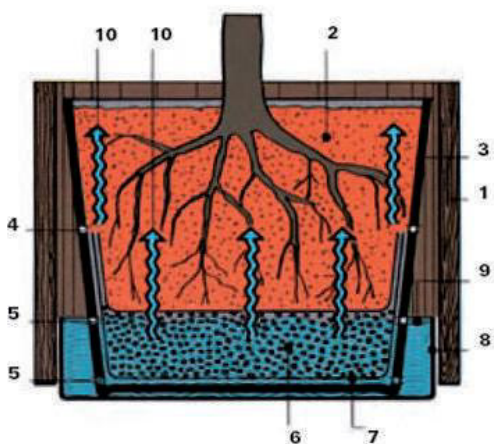

1 fioriera in legno  
Bepflanzungselement in Holz  
ossature en bois  
planting element in wood

6 serbatoio d'acqua  
Wasserspelcher  
Reservoir  
Water reservoir

2 terreno  
Erdreich  
terreau  
soil

7 panno assorbente acqua  
Wassersaugtuch  
natte hydrophile  
water adsorbing cloth

3 contenitore in plastica  
Kunststoffbehälter  
contenant plastique  
plastic container

8 Argilla espansa per il flusso di acqua  
Blähton für Wasserdurchfluss  
Argile expansé dans une natte hydrophile  
expanded clay for water flow

4 apertura d'aerazione  
Luftöffnung  
ouverture d'aération  
air opening

9 livello dell'acqua  
Wasserspiegel  
niveau d'eau  
water level

5 fori per l'acqua  
Öffnung für Wasserdurchfluss  
ouverture pour l'écoulement de l'eau  
opening for water flow

10 flusso dell'umidità  
Feuchtigkeitsfluss  
capillarité  
way of humidity

## cascara

mod. 130I, 130II, 130III, 130VI

---



Peso | Gewicht | Poids | Weight: 29 | 46 | 81 | 118 kg

## cascara

mod. 140I, 140II, 140III

---



Peso | Gewicht | Poids | Weight: 29 | 47 | 83 kg

## cascara

mod. 170I, 170II

---



Peso | Gewicht | Poids | Weight: 52 | 72 kg

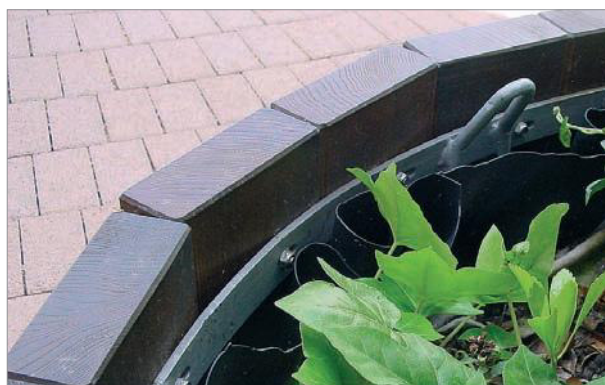

**Rivestimento:** realizzato con listelli di sezione esagonale in legno duro trattato o non trattato. **Vasca:** realizzata in lamiera decapata zincata a fuoco da 2 mm. Piedini di tubi d'acciaio quadrati zincato.

**Revêtement:** réalisé avec des lattes à section hexagonale en bois dur sans ou avec traitement. **Vasque:** réalisée en tôle décapée galvanisée à chaud de 2 mm. Pieds en tube acier rectangulaire galvanisé au chaud.

**Ummantelung:** bestehend aus sechseckigen Latten aus erstklassigem Hartholz behandelt oder unbehandelt. **Boden:** in verschiedenen Formen aus feuerverzinktem Stahlblech 2 mm. Füße aus feuerverzinktem Stahl-Vierkanrohr.

**Casing:** consisting of hexagonal slats in hardwood untreated or treated. **Bottom:** available in various forms, made of galvanized steel sheet 2 mm, with feet of galvanized steel rectangular tube.

# pyramid

mod. 126, 126l



Peso | Gewicht | Poids | Weight: 400 kg | 35 kg

Strutture di superficie | Oberflächenstrukturen | Structures de surface | Surface structures



Ahr



Bianco Carrara

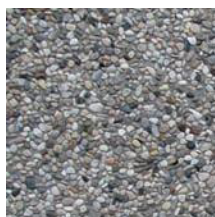

Etsch

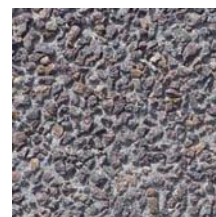

Porphy



Porphyr rosa | rosa | rose | pink



Rosa Corallo



Sardo Granit

Fioriera in forma rettangolare in calcestruzzo armato, estremamente vibrato e compatto, assolutamente resistente al gelo ed impermeabile, munito di 3 piedini regolabili per il livellamento del terreno fino ad una pendenza max. del 3,5%. Possibilità di composizione tra fioriere e d'integrazione d'un sedile.

Jardinière de forme triangulaire en béton armé, extrêmement vibré et compact, absolument résistant au gel et imperméable, muni de 3 pieds incorporés pour le nivellement du terrain pour une pente max. de 3,5%. Possibilité de composition entre jardinières et d'intégration d'un siège.

Die Pflanzschale wird aus hochwertigem, armiertem und vibriertem Stahlbeton gefertigt. Oberfläche in diversen Farben und Effekten/Körnungen lieferbar. Eingebaute Stellfüße: erlauben eine genaue Nivellierung auch auf unebenem Boden. Pro Pflanzschale kann ein Gefälle von max. 3,5% ausgeglichen werden. Es besteht auch die Möglichkeit der Anbringung einer Bank.

The planter is made of high quality, reinforced and vibrated concrete. Surface available in various colors and effects/grits. Adjustable feet allow precise leveling on uneven ground. A gradient of max 3.5 % per planter can be compensated. Also possible with integrated seating.



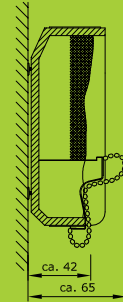
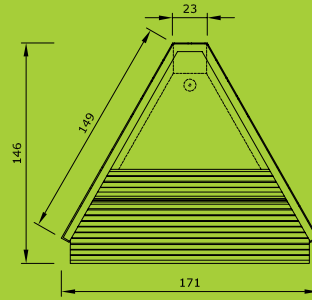
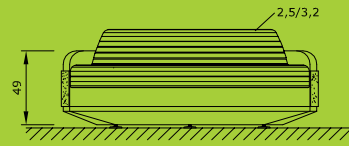
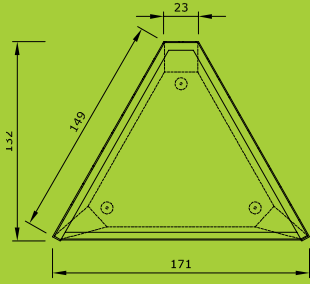

mod. 126

mod. 126l

descrizione tecnica e disegni dwg | technische Beschreibung und dwg Zeichnungen | technical description and dwg drawings | description technique et dessins dwg: [www.euroform-w.com](http://www.euroform-w.com)



Bucarest, Romania

## ortotavolo

mod. 6500

for  
seniors

for  
kids



Peso | Gewicht | Poids | Weight: 52 kg

**Telaio:** ferro zincato 3 mm; a forma di „u“ 12x80 mm. **Vasca:** lamiera zincata spess. 2 mm. **Rivestimento della vasca:** sui due lati con listelli in legno duro non trattato o trattato.

### ACCESSORI

**Libreria:** lamiera zincata spess. 2 mm con 3 scaffali.

**Maniglione:** In ferro piatto 5x50 mm e tubo orizzontale Ø42 mm.

**Vasca interna:** lamiera zincata spess. 2 mm.

**Tasca esterna:** asportabile e utilizzabile per appoggiare gli attrezzi da lavoro. Lamiera zincata spess. 2 mm.

**Trattamento a polvere:** colori RAL a scelta. **Fissaggio:** collocamento o su pavimento solido.

**Cadre:** fer galvanisé 3 mm ; en forme de “u” 12x80 mm.

**Vasque:** en tôle galvanisée épais. 2 mm. **Revêtement de la vasque :** des deux côtés, avec des lattes en bois dur sans traitement de surface.

### ACCESSOIRES

**Bibliothèque:** tôle d’acier 2 mm avec 3 étagères.

**Poignée:** fer plat 5x50 mm et tube horizontal Ø42 mm.

**Vasque interne:** tôle galvanisée épais. 2 mm.

**Vasque externe:** Amovible et utilisable pour poser les outils de travail. Tôle galvanisée épais. 2 mm.

**Revêtement poudre polyester:** Coloris RAL au choix. **Scellement:** Dans le sol ou autostable.

## ortofioriera

mod.6502



Peso | Gewicht | Poids | Weight: 31 kg

**Gestell:** Blech verzinkt 3 mm; u-förmig gebogen 12x80 mm. **Wanne:** verzinktes Blech 2 mm. Verkleidung der Wanne: auf beiden Längsseiten mit Hartholzbohlen, unbehandelt oder behandelt.

### ZUBEHÖR

**Regal:** Blech verzinkt 2 mm mit 3 Ablagen.

**Handgriff:** Flacheisen 5x50 mm und Rundrohr Ø42 mm.

**Zusatzwanne (intern):** Aus verzinktem Blech 2 mm.

**Zusatzwanne (extern):** Abnehmbar zur Aufbewahrung von Werkzeug. Aus verzinktem Blech 2 mm.

**Pulverbeschichtung:** RAL-Farben nach Wahl. **Befestigung:** zum Aufschrauben oder freiem Aufstellen.

**Frame:** metal sheet 3 mm; u-shaped bent 12x80 mm.

**Tank:** galvanized steel sheet, 2 mm thick. **Tank lining:** hard wood boards on both sides, untreated.

### ACCESSORIES

**Bookshelf:** 2 mm thick galvanized steel sheet with 3 shelves.

**Handlebar:** flat bar 5x50 mm and horizontal tube Ø42 mm.

**Internal tank:** 2 mm thick galvanized steel sheet.

**External pocket:** can be removed and used to keep the working tools. In 2 mm thick galvanized steel sheet.

**Powder coating:** RAL colour to choose. **Fixation:** fixed in the ground or free-standing.

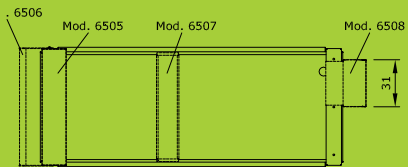
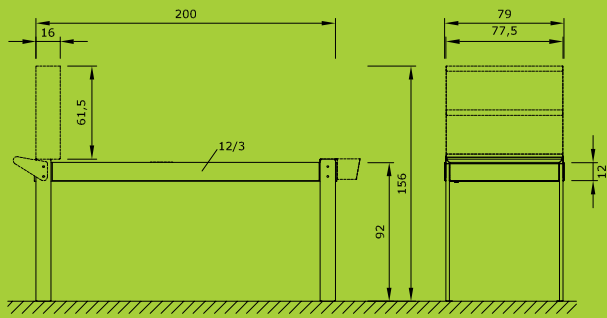

mod. 6500

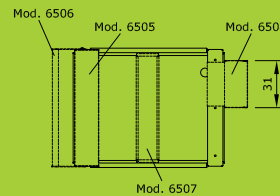
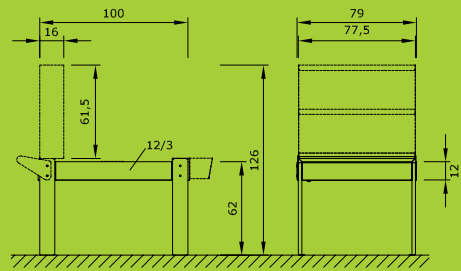

mod. 6502

descrizione tecnica e disegni dwg | technische Beschreibung und dwg Zeichnungen | technical description and dwg drawings | description technique et dessins dwg: [www.euroform-w.com](http://www.euroform-w.com)

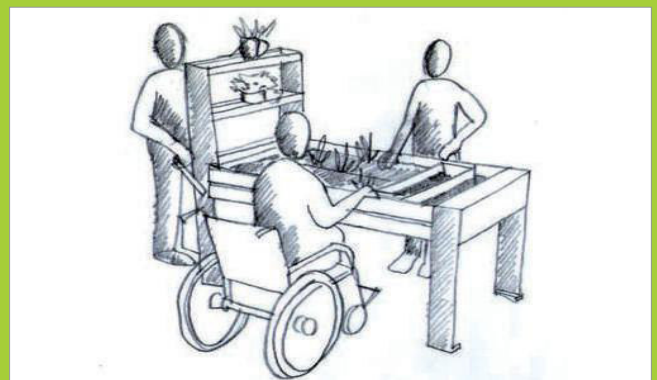

# drop

mod. 3600

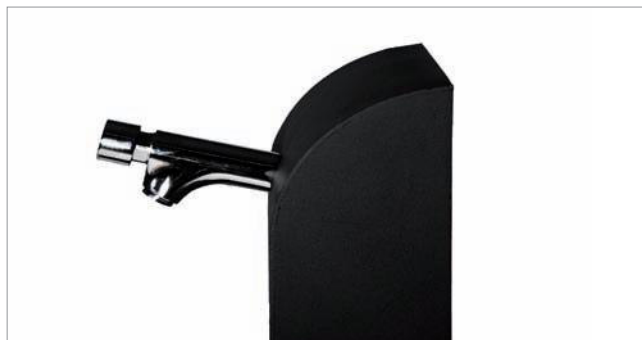

Peso | Gewicht | Poids | Weight: 38 kg

**Corpo:** lamiera d'acciaio spess. 3 mm zincato. **Base:** lamiera d'acciaio forata spess. 5 mm zincato a fuoco. **Rubinetto:** acciaio inox con pulsante da parete con arresto temporizzato. **Optional:** gradino in lamiera d'acciaio forata spess. 3 mm. **Trattamento a polvere:** Colori RAL a scelta.

**Corps:** tôle en acier épais. 3 mm galvanisé. **Base:** tôle en acier perforée épais. 5 mm galvanisé à chaud. **Robinnet:** acier inox avec bouton mural et arrêt temporisé. **En option:** marche en tôle en acier perforée épais. 3 mm. **Traitement par poudrage:** Couleurs RAL au choix.

**Korpus:** Stahlblech 3 mm verzinkt. **Basis:** gelochtes Stahlblech 5 mm feuerverzinkt. **Wasserhahn:** aus Edelstahl mit automatischer Abschaltfunktion. **Optional:** Stufe aus gelochtem Stahlblech 3 mm feuerverzinkt. **Pulverbeschichtung:** RAL-Farben nach Wahl.

**Material:** 3 mm steel sheet galvanized. **Basis:** 5 mm perforated steel sheet hot-dip galvanized. **Water tap:** in stainless steel with automatic shutdown function. **Optional:** step of perforated steel sheet 3 mm. **Powder coating:** RAL colour to choose.

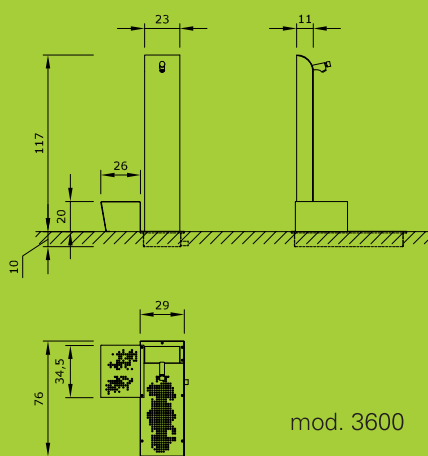

descrizione tecnica e disegni dwg | technische Beschreibung und dwg Zeichnungen | technical description and dwg drawings | description technique et dessins dwg: [www.euroform-w.com](http://www.euroform-w.com)







# shelters

coperture | überdachungen | couverture

Le nostre coperture possono essere utilizzate per esigenze diverse: come copertura per biciclette, fermata bus, copertura per macchine o moto ecc.. In questo modo è possibile creare una linea unica per tutte le coperture inserite nel territorio pubblico e si conia un'inconfondibile personalità della città. Numerosi accessori danno alla copertura un suo carattere individuale.

Unsere Überdachungen können auf vielfältige Weise eingesetzt werden: als Fahrradüberdachung, Bushaltestelle, Auto- oder Motorradüberdachung usw. Damit wird eine einheitliche Linie für die platzierten Überdachungen im Gemeindegebiet geschaffen und dadurch die unverwechselbare Persönlichkeit der Stadt geprägt. Zahlreiche Zusatzelemente geben der Überdachung dabei einen individuellen Charakter.

Nos couvertures peuvent être utilisées pour différentes exigences : en tant que couvertures pour vélos, arrêt de bus, couvertures pour voitures ou motos, etc. De cette manière, il est possible de créer une ligne unique pour toutes les couvertures utilisées sur le territoire public et forger une personnalité incomparable pour chaque ville. De nombreux accessoires donnent à la couverture son caractère individuel.

Our shelters can be used in many ways: as a bike shelter, bus stop shelter, motorcycle or car shelter etc. In this way it is possible to create a basic line for all shelters which are placed in a municipality, in order to create an unique personality of the city. With the integration of various accessories it is possible to give the shelter a customized character.



Grenoble, France



Ora, Bolzano, Italy



Nyropsgade Copenhagen, Denmark



Kostheim, Mainz, Germany



Gennevilliers, France



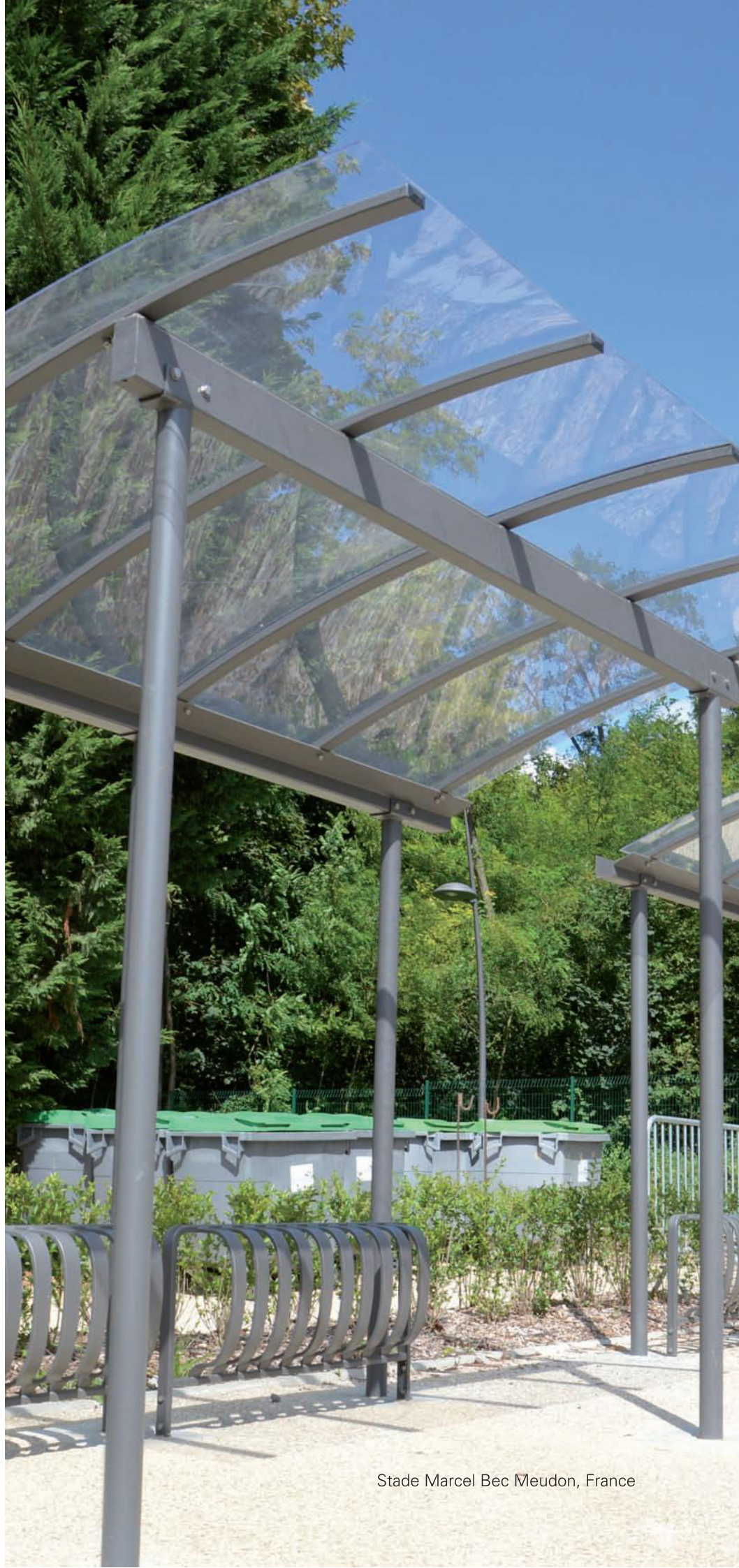

Stade Marcel Bec Meudon, France

# combine your style

## Model

combi, galleria, light, linea, wing, vela

## Function

copertura per biciclette/moto | pensiline per bus | carport | copertura fotovoltaica

fahrrad/motorad -überdachung | haltestellen | carport | fotovoltaiküberdachung

abris à vélos/moto | abribus | systèmes pergolas | couverture photovoltaïque

bicycle/moto shelter | bus shelter | carport | photovoltaic roofing



## Green energy

Risparmio energetico con l'installazione di sistemi fotovoltaici che producono l'energia necessaria per gestire lo spazio urbano.

Energieeinsparung mit Photovoltaiklösungen um den benötigten Strom für den Freiraum zu erzeugen.

Économie énergétique grâce à l'installation de systèmes photovoltaïques qui produisent l'énergie nécessaire pour gérer l'espace urbain.

Energy saving through the installation of photovoltaic systems that produce the necessary energy for managing the urban space.

## Side panels

policarbonato | Polycarbonat | polycarbonate | polycarbonate

Listelli in legno duro | Hartholzbohlen | Lattes en bois exotique | Hard wood slats

Lamiera forata | Lochblech | Tole perforée | Perforated metal

Lamiera stirata | Streckmetall | Métal déployé | Expanded metal

## Sound

Gli elementi di diffusione sonora arricchiscono lo spazio urbano e lo trasformano in una vera e propria oasi di benessere per i cittadini e i turisti, potendoli utilizzare nel contempo per comunicare importanti informazioni.

Integrierte Soundelemente bereichern den Freiraum und machen ihn zu einer wahren Wohlfühloase für Stadtbewohner und Touristen. Gleichzeitig können dadurch wichtige Informationen vermittelt werden.

Les éléments de diffusion sonore enrichissent l'espace urbain et le transforment en une vraie oasis de bien-être pour les citadins et les touristes, pouvant en même temps être utilisés pour communiquer des informations importantes.

Sound system installations enhance an urban space and transform it into an authentic oasis of wellbeing for residents and tourists alike; at the same time they can be used for communicating important information.



## Furniture

panchine, cestini portarifiuti, posaceneri, portabici, bacheche

Bänke, Abfallbehälter, Ascher, Fahrradständer, Anschlagetafeln

bancs, corbeilles, cendrier, rangements pour cycles, panneau d'affichage

benches, litter bins, ashtrays, bike racks, notice boards,



## Light

La luce valorizza lo spazio pubblico, aiuta ad orientarsi e migliora il benessere della popolazione. Noi offriamo soluzioni ecologiche, con un occhio naturalmente attento ai consumi energetici.

Durch Licht wird der öffentliche Freiraum aufgewertet, bietet Orientierung und verbessert das Wohlbefinden der Bevölkerung. Wir bieten ökologische Lösungen, welche natürlich auch den Energieverbrauch berücksichtigen.

La lumière valorise l'espace public, aide à s'orienter et améliore le bien-être de la population. Nous offrons des solutions écologiques, avec un oeil naturellement attentif aux consommations énergétiques.

Light enhances public spaces, helps us to find our way and improves the wellbeing of the population. We offer ecological solutions, with a naturally keen eye on energy consumption.



## combi

mod. 740, 750



Peso | Gewicht | Poids | Weight: 265 kg | 443 kg

**Versioni:** unilaterale o bilaterale. **Struttura portante:** Montanti in tubo tondo Ø60 mm, traverse in tubo rettangolare 100x60 mm e lamiera d'acciaio 8 mm, zincato a fuoco. **Copertura:** traverse in tubo rettangolare 60x30 mm, Policarbonato spess. 6 mm. **Trattamento a polvere:** colori RAL a scelta. **Carico neve:** 150 kg/m<sup>2</sup>. **Fissaggio:** in calcestruzzo o su pavimento solido.

**Version:** unilatérale ou bilatérale. **Structure portante:** Montants en tube rond Ø60 mm, traverses en tube rectangulaire 100x60 mm et en acier épaisseur 8 mm galvanisé à chaud. **Couverture:** traverses en tube rectangulaire 60x30 mm, en Polycarbonate 6 mm. **Revêtement poudre polyester:** Coloris RAL au choix. **Charge admise de la couverture:** 150 kg/m<sup>2</sup>. **Fixation:** dans le sol ou en surface.

Optional: pareti laterali | Seitenpaneele | lateral walls | parois latérales

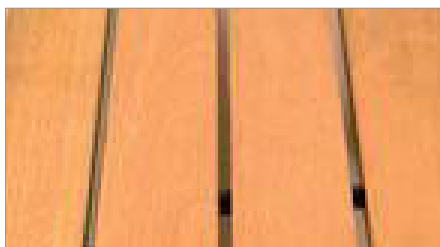

Listelli in legno duro  
Hartholzbohlen  
Lattes en bois exotique  
Hard wood slats

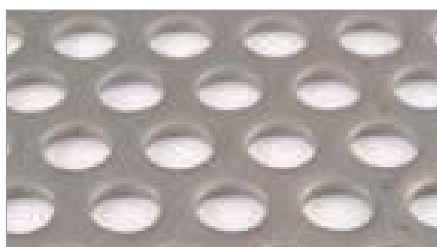

Lamiera forata bordata  
Lochblech gerändelt  
Tole perforée  
Perforated metal



Policarbonato ondulato  
Polycarbonate gewellt  
Polycarbonate corrugated  
Polycarbonate ondulé

## combi

mod. 740D, 750D



Peso | Gewicht | Poids | Weight: 358 kg | 595 kg

**Versionen:** ein- oder doppelseitig. **Struktur:** Steher aus Rundrohr Ø60 mm, Querträger aus Rechteckrohr 100x60 mm und Stahlblech 8 mm, feuerverzinkt. **Überdachung:** Querträger aus Rechteckrohr 60x30 mm, Polycarbonat 6 mm. **Pulverbeschichtung:** RAL-Farben nach Wahl. **Schneelast:** 150 kg/m<sup>2</sup>. **Befestigung:** zum Einbetonieren oder zum Aufschrauben.

**Versions:** single or double sided. **Structure:** posts in round section pipe Ø60 mm, rectangular section pipe 100x60 mm and metal sheet 8 mm, hot-dip galvanized. **Roof:** rectangular section pipe 60x30 mm. Polycarbonate 6 mm. **Powder coating:** RAL colour to choose. **Snow charge:** 150 kg/m<sup>2</sup>. **Fixation:** fixed in the ground, surface mounting.

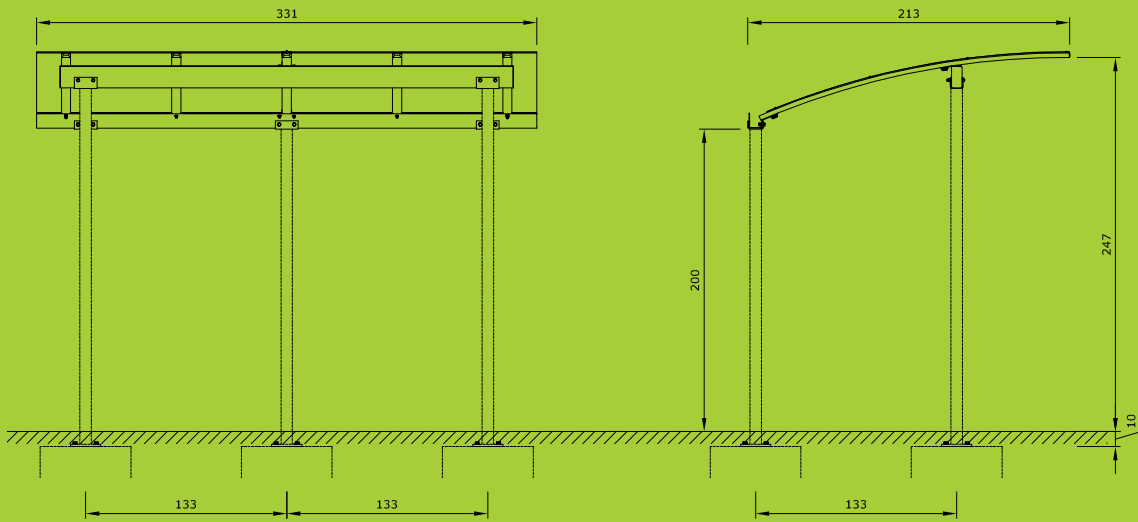

mod. 740

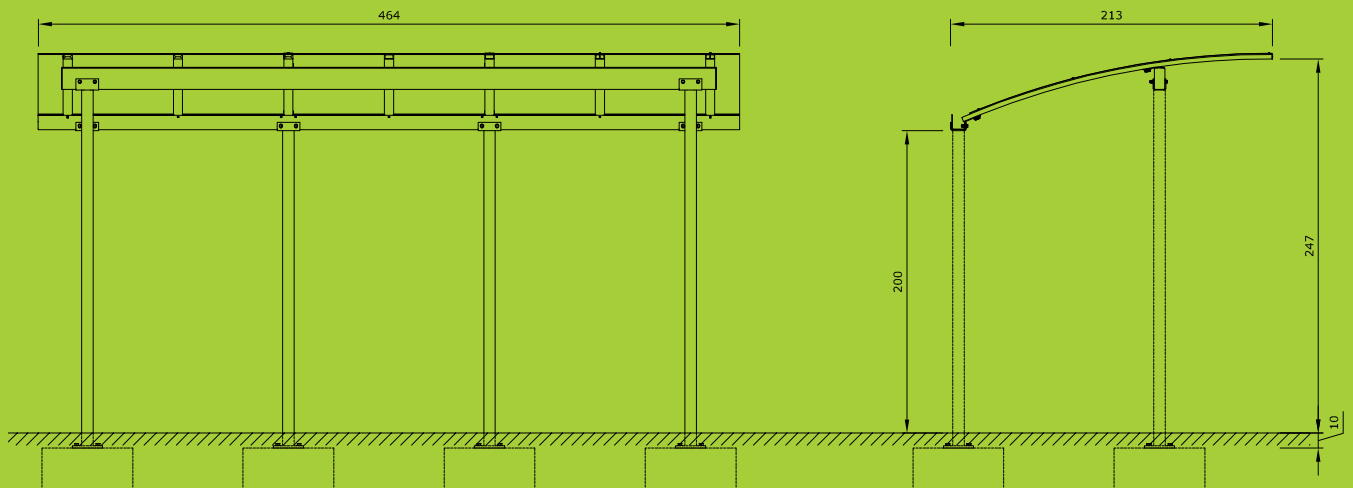

mod. 750

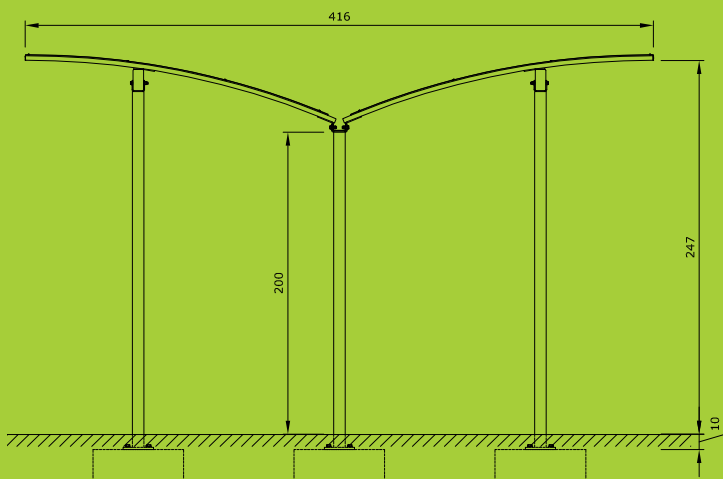

mod. 740D | 750D

## galleria

mod. 710



Peso | Gewicht | Poids | Weight: 160 kg

**Versioni:** unilaterale o bilaterale. **Struttura portante:** pali in tubo quadro 50x50 mm. **Supporto copertura:** tubi retangolari 30x60 mm. **Materiale copertura:** policarbonato Makrolon 16 mm. **Carico neve:** 150 kg/m<sup>2</sup>. **Trattamento a polvere:** Colori RAL a scelta. **Fissaggio:** in calcestruzzo o su pavimento **solido**.

**Versions:** rangement unilatéral ou bilatéral. **Structure portante:** poteaux en tube d'acier 50x50 mm. **Support couverture:** tubes en acier 30x60 mm. **Matériaux couverture:** polycarbonate Makrolon 16 mm. **Charge admise de la couverture:** 150 kg/m<sup>2</sup>. **Thermolaquage:** Coloris RAL au choix. **Fixation:** dans le sol ou en surface.

## galleria

mod. 710D



Peso | Gewicht | Poids | Weight: 255 kg

**Versionen:** ein- oder zweiseitig. **Steher:** Vierkantrohr 50x50 mm. **Querverbindungen:** Rechteckrohr 30x60 mm. **Material Überdachung:** Polycarbonat Makrolon 16 mm. **Schneelast:** 150 kg/m<sup>2</sup>. **Pulverbeschichtung:** RALFarben nach Wahl. **Befestigung:** zum Einbetonieren oder zum Aufschrauben.

**Versions:** one or double sided version. **Posts:** 50x50 mm square steel bar. **Cross-supports:** 30x60 mm square steel bars. **Material roofing:** Polycarbonat Makrolon 16 mm. **Snow charge:** 150 kg/m<sup>2</sup>. **Powder coating:** RAL colour to choose. **Fixation:** fixed in the ground or surface mounting.

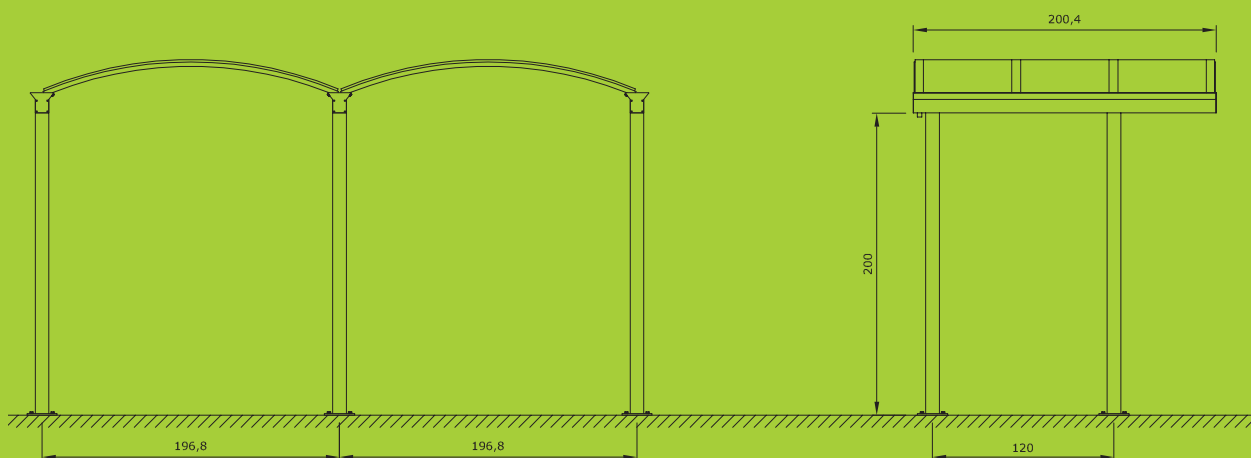

mod. 710

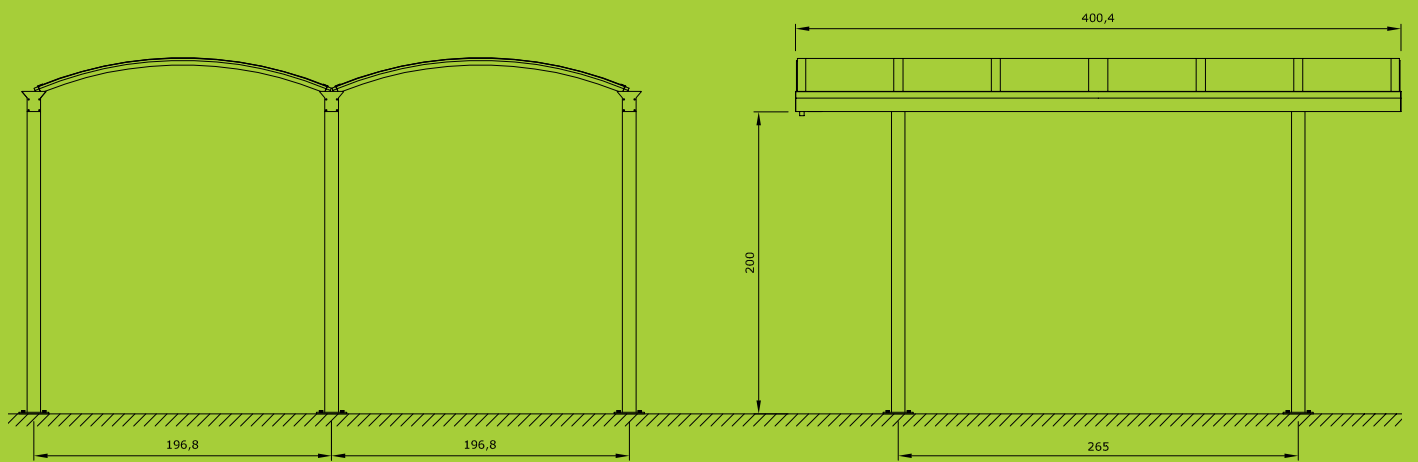

mod. 710D

## light

mod. 720



Peso | Gewicht | Poids | Weight: 130 kg

**Versioni:** unilaterale o bilaterale. **Struttura portante:** travi in tubo quadro 45x45 mm zincato a fuoco. **Supporto copertura:** tubi quadri 40x40 mm zincato a fuoco. **Materiale copertura:** Pannelli ondulati polycarbonato. **Carico neve:** 150 kg/m<sup>2</sup>. **Trattamento a polvere:** Colori RAL a scelta. **Fissaggio:** in calcestruzzo o su pavimento solido.

**Versions:** rangement unilatéral ou bilatéral. **Structure portante:** poteaux en tube d'acier 45x45 mm galvanisé à chaud. **Support couverture:** tubes en acier 40x40 mm galvanisé à chaud. **Matériaux couverture:** panneaux de polycarbonate ondulé. **Charge admise de la couverture:** 150 kg/m<sup>2</sup>. **Thermolaquage:** Coloris RAL au choix. **Fixation:** dans le sol ou en surface.

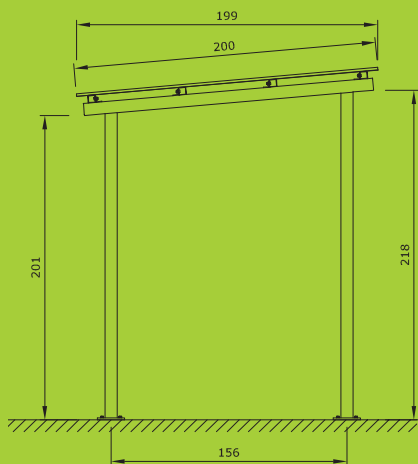

mod. 720

## light

mod. 720D



Peso | Gewicht | Poids | Weight: 260 kg

**Versionen:** ein- oder zweiseitig. **Steher:** Vierkantrohr 45x45 mm feuerverzinkt. **Querverbindungen:** Vierkantrohr 40x40 mm feuerverzinkt. **Material Überdachung:** Polycarbonat Wellplatten. **Schneelast:** 150kg/m<sup>2</sup>. **Pulverbeschichtung:** RAL Farben nach Wahl. **Befestigung:** zum Einbetonieren oder zum Aufschrauben.

**Versions:** one or double sided version. **Posts and supports:** 45x45 mm square steel hot-dip galvanized. **Cross-supports:** 40x40 mm square steel hot-dip galvanized. **Material roofing:** Corrugated polycarbonate panels. **Snow charge:** 150 kg/m<sup>2</sup>. **Powder coating:** RAL colour to choose. **Fixation:** fixed in the ground or surface mounting.

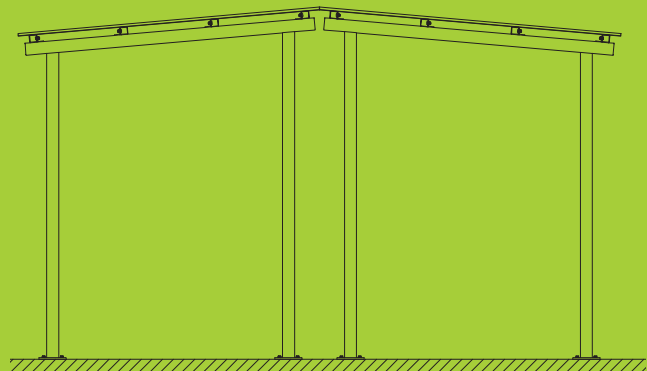

mod. 720D





Condominium, via Roma, Bolzano, Italy

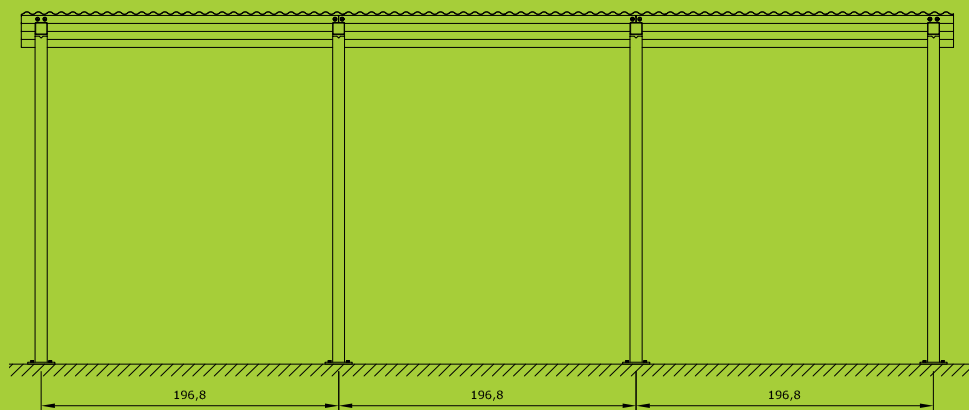

# linea

mod. 800



Peso | Gewicht | Poids | Weight: 265 kg

**Versione:** unilaterale. **Struttura portante:** montanti in ferro piatto 6x80 mm, zincato a fuoco. **Copertura:** traverse in lamiera d'acciaio 3 mm e polycarbonato o lamiera trapezoidale. **Carico neve:** 150 kg/m<sup>2</sup>. **Trattamento a polvere:** colori RAL a scelta. **Fissaggio:** in calcestruzzo o su pavimento.

**Version:** unilateral. **Structure portante:** montants en fer plat 6x80 mm, galvanisé. **Couverture:** traverses en acier 3 mm et polycarbonate ou feuille trapézoïdale. **Charge admise de la couverture:** 150 kg/m<sup>2</sup>. **Thermolaquage:** coloris RAL au choix. **Fixation:** dans le sol ou en surface.

**Versionen:** einseitig. **Struktur:** Steher aus Flacheisen 6x80 mm, feuerverzinkt. **Überdachung:** Querträger aus Stahlblech 3 mm und Polycarbonat oder Trapezblech. **Schneelast:** 150 kg/m<sup>2</sup>. **Pulverbeschichtung:** RAL-Farben nach Wahl. **Befestigung:** zum Einbetonieren oder zum Aufschrauben.

**Version:** single side. **Structure:** flat iron posts 6x80 mm, hot-dip galvanized. **Roof:** crossbeams in steel sheet thickness 3 mm and polycarbonate or trapezoidal sheet. **Snow charge:** 150 kg/m<sup>2</sup>. **Powder coating:** RAL colours to choose. **Fixation:** fixed in the ground or surface mounting.

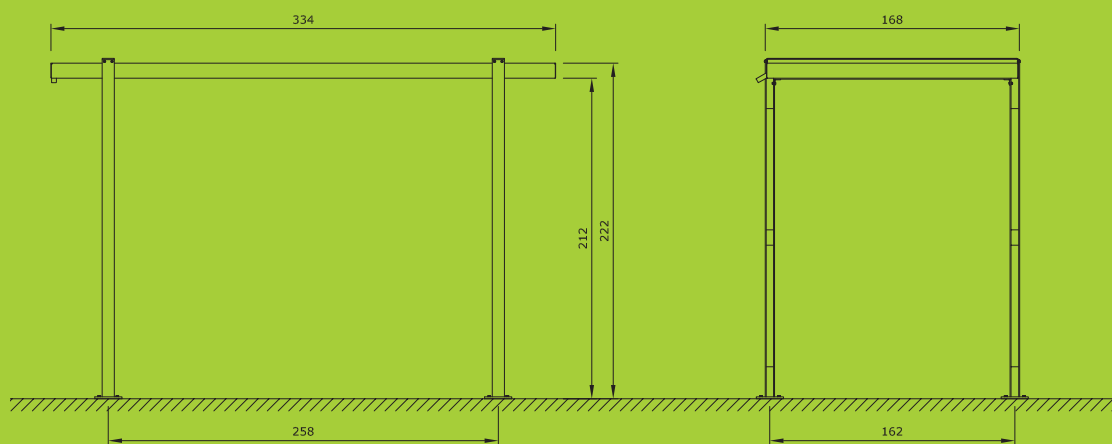

mod. 800

descrizione tecnica e disegni dwg | technische Beschreibung und dwg Zeichnungen | technical description and dwg drawings description technique et dessins dwg: [www.euroform-w.com](http://www.euroform-w.com)



Bolzano, Italy

Optional: pareti laterali | Seitenpaneele | lateral walls | parois latérales

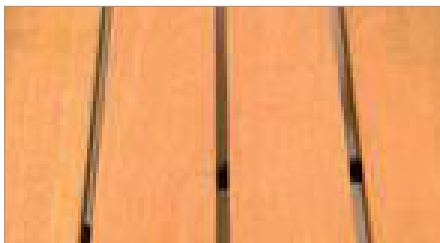

Listelli in legno duro  
Hartholzbohlen  
Lattes en bois exotique  
Hard wood slats

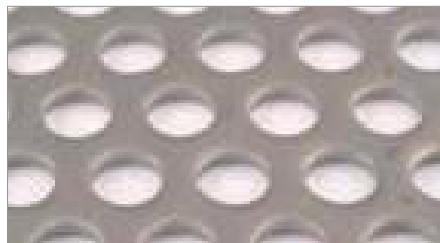

Lamiera forata bordata  
Lochblech gerändelt  
Toile perforée  
Perforated metal



Policarbonato  
Polycarbonat  
Polycarbonate  
Polycarbonate

# wing

mod. 700



Peso | Gewicht | Poids | Weight: 410 kg

**Versioni:** unilaterale o bilaterale. **Struttura portante:** Montanti in tubo tondo Ø50 mm, travi IPE 100 mm, tubo rettangolare 60x30 mm e profilo ad "L" 100x100 mm, zincato a fuoco. **Carico neve:** 150 kg/m<sup>2</sup>. **Trattamento a polvere:** Colori RAL a scelta. **Copertura:** in policarbonato Makrolon 16 mm. **Fissaggio:** in calcestruzzo o su pavimento solido.

**Versions:** simple ou double. **Structure portante:** poteaux en tubes d'acier Ø50 mm, supports IPE 100 mm. Tubes en acier 60x30 mm et L-profil 100x100 mm, en acier galvanisé à chaud. **Charge admise de la couverture:** 150 kg/m<sup>2</sup>.

**Revêtement poudre polyester:** coloris RAL. **Couverture:** Polycarbonate Makrolon 16 mm. **Fixation:** dans le sol ou en surface.

# wing

mod. 700D



Peso | Gewicht | Poids | Weight: 730 kg

**Versionen:** ein- oder doppelseitig. **Struktur:** Steher aus Rundrohr Ø50 mm, IPE Träger 100 mm, Rechteckrohr 60x30 mm und „L“ Profil 100x100 mm feuerverzinkt. **Schneelast:** 150 kg/m<sup>2</sup>. **Pulverbeschichtung:** RAL-Farben nach Wahl. **Überdachung:** Polycarbonat Stegplatten Makrolon 16 mm. **Befestigung:** zum Einbetonieren oder zum Aufschrauben.

**Versions:** single or double sided. **Structure:** posts in round section pipe Ø50 mm, beams IPE 100 mm, rectangular section pipe 60x30 mm and "L" section 100x100 mm, hot-dip galvanized. **Powder coating:** RAL colour to choose. **Snow charge:** 150 kg/m<sup>2</sup>. **Roof:** Makrolon polycarbonate 16 mm. **Fixation:** fixed in the ground or surface mounting.

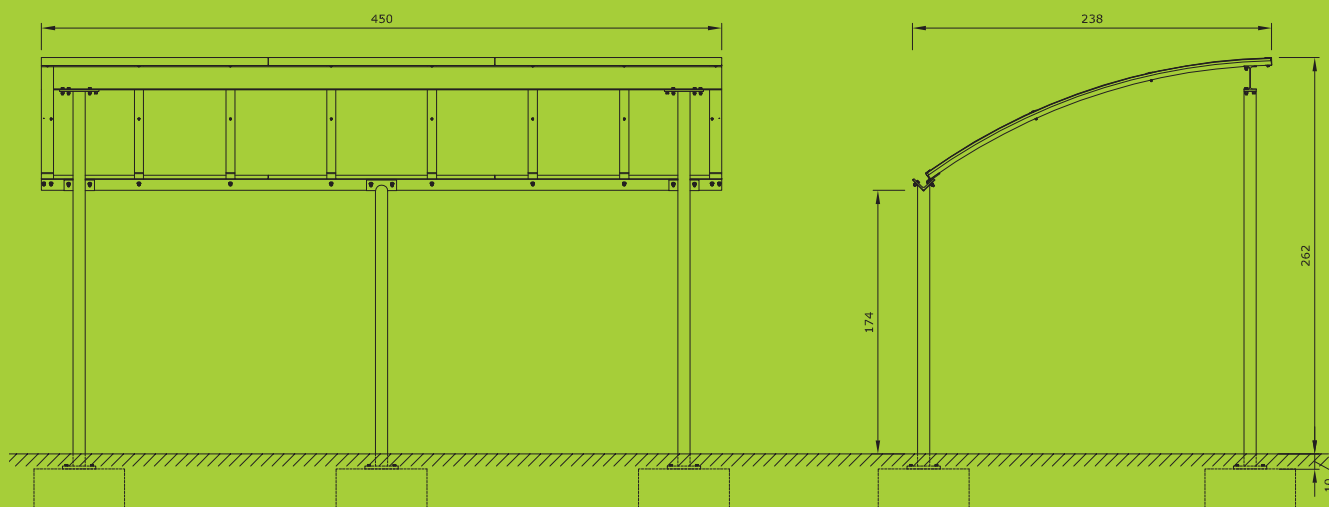

mod. 700

descrizione tecnica e disegni dwg | technische Beschreibung und dwg Zeichnungen | technical description and dwg drawings description technique et dessins dwg: [www.euroform-w.com](http://www.euroform-w.com)



Chiusa, Bolzano, Italy



# vela

mod. 730



Peso | Gewicht | Poids | Weight: 365 kg

**Versione:** unilaterale. **Struttura portante:** montanti in tubi tondi diam. 60,3 mm e travi in tubi tondi Ø76,1 mm, zincato a fuoco. **Copertura:** in tubo rettangolare 60x30 mm, zincato a fuoco e policarbonato Makrolon 16 mm. **Carico neve:** 150 kg/m<sup>2</sup>. **Trattamento a polvere:** Colori RAL a scelta. **Fissaggio:** in calcestruzzo o su pavimento solido.

**Version:** unilatérale. **Structure portante:** poteaux en tubes d'acier galvanisé à chaud Ø60,3 mm. Tube d'acier galvanisé à chaud Ø76,1 mm. **Couverture:** tube rectangulaire de 60x30 mm, galvanisé et polycarbonate Makrolon 16 mm. **Charge admise de la couverture:** 150 kg/m<sup>2</sup>. **Thermolaquage:** Coloris RAL au choix. **Fixation:** à sceller dans le sol ou à fixer en surface.

**Version:** einseitig. **Struktur:** Steher aus Rundrohr 76,1 mm und Querträger aus Rundrohr 60,3 mm, feuerverzinkt. **Überdachung:** Vierkantrohr 60x30 mm, feuerverzinkt. Polycarbonat Stegplatten Makrolon 16 mm. **Schneelast:** 150kg/m<sup>2</sup>. **Pulverbeschichtung:** RAL-Farben nach Wahl. **Befestigung:** zum Einbetonieren oder zum Aufschrauben.

**Version:** single side. **Structure:** posts in pipe Ø60,3 mm and beams in round section pipe Ø76,1 mm, hot-dip galvanized. **Roof:** rectangular tube 60x30 mm, hot-dip galvanized and polycarbonate Makrolon 16 mm. **Snow charge:** 150 kg/m<sup>2</sup>. **Powder coating:** RAL colour to choose. **Fixation:** fixed in the ground or surface mounting.

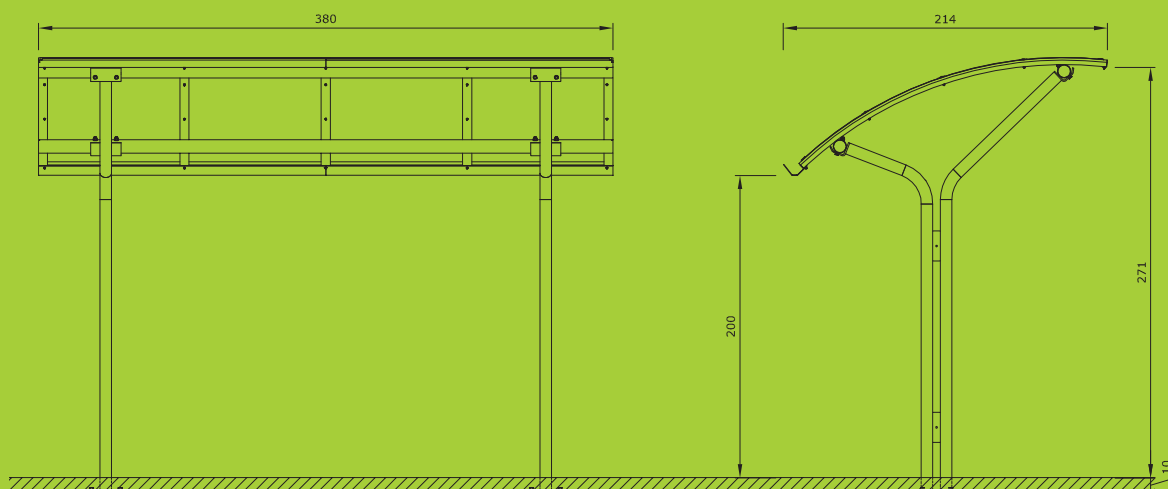

mod. 730

descrizione tecnica e disegni dwg | technische Beschreibung und dwg Zeichnungen | technical description and dwg drawings description technique et dessins dwg: [www.euroform-w.com](http://www.euroform-w.com)



Agricultural School in Teodone, Brunico, Italy



# pergola systems

Customized solutions for several functions

## Function

Tettoie, isole ecologiche, passaggi, coperture per terrazze

Überdachung, Müllinhausung, Durchgänge, Terrassenüberdachung

Toits, îles écologiques, passages, couvertures pour terrasses

Sheds, junkyards, steps, patio roofs

## Dimension, Form

Quadrate, rettangolari, esagonali, forme e dimensioni personalizzabili

Quadratisch, rechteckig, sechseckig, individuelle Form und Dimensionen

Carrés, rectangulaires, hexagones, formes et dimensions personnalisées

Square, rectangular, hexagonal, fully customisable shapes and sizes

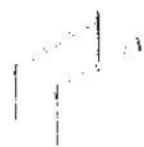
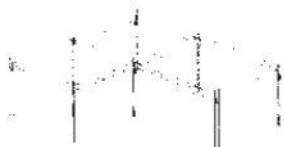
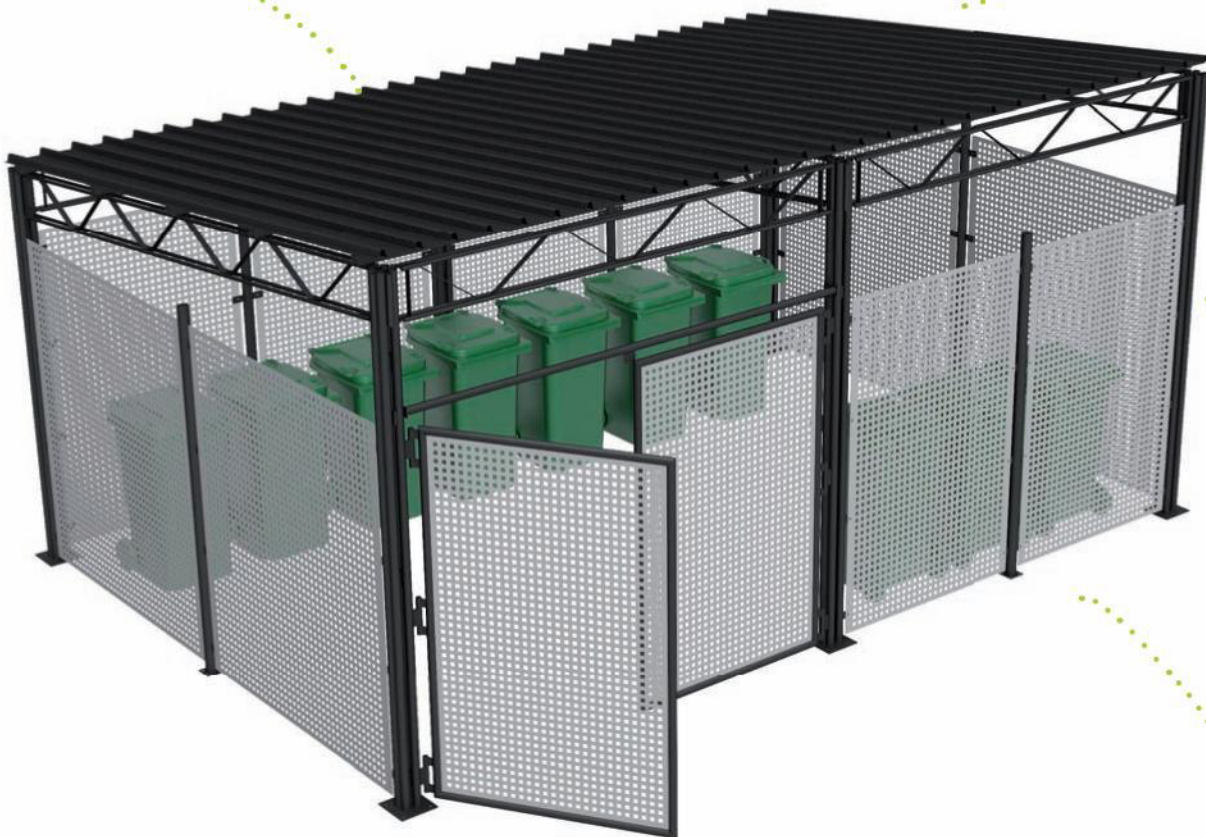



## Material

Montanti a tubi, travi reticolari  
Rohrbündelstützen, Fachwerkträger  
Montants à tubes, poutres en treillis  
Vertical tubes, girders

## Side panels

Grigliati, lamiera forate, policarbonato  
Rankgitter, Lochblech, Polycarbonat  
Treillis, tôles percées, polycarbonate  
Grilles, perforated sheets, polycarbonate

## Roofing

A richiesta con o senza tettoia in legno, lamiera grecata, policarbonato  
Auf Wunsch mit oder ohne Dach aus Holz, Trapezblech, Polycarbonat.  
Sur demande, avec ou sans toit en bois, tôle ondulée, polycarbonate.  
On request with or without wooden shed, corrugated sheet, polycarbonate

## Furniture

panchine, cestini portarifiuti, posaceneri, portabici, bacheche

Bänke, Abfallbehälter, Ascher, Fahrradständer, Anschlagetafeln

bancs, corbeilles, cendrier, rangements pour cycles, panneau d'affichage

benches, litter bins, ashtrays, bike racks, notice boards,



# pergola systems



**Montanti:** tubolare multiplo zincato a fuoco Ø42 mm, lunghezza 295 cm. **Travi a traliccio:** 4 tubi tondi zincati a fuoco, Ø20 mm, lunghezza a scelta. **Montanti in legno:** legno larice lamellare 80x120 mm. **Travi in legno:** legno larice lamellare 80x160 mm, 80x120 mm. **Pannello frangisole:** lamiera stirata spess. 1,5 mm, bordata spess. 2,5 mm. **Rete:** graticola zincata spess. 4 mm con maglia da 50x100 mm. **Trattamento a polvere:** Colori RAL a scelta. **Fissaggio:** in calcestruzzo o su pavimento solido.

**Poteaux-suppports:** tubes Ø42 mm en acier galvanisé à chaud - longueur 295 cm. **Linteaux:** 4 tubes Ø20 mm - en acier galvanisé à chaud - longueur au choix. **Montants en bois:** mélèze lamellé collé 80x120 mm. **Traverses en bois:** mélèze lamellé collé 80x160 mm, 80x120 mm. **Panneaux pare-soleil:** métal déployé de 1,5 mm - avec rebord de 2,5 mm d'épaisseur. **Treillis:** en acier galvanisé - maille 50x100 mm. **Thermolaquage:** Coloris RAL au choix. **Fixation:** à sceller dans le sol ou à fixer en surface.

**Rohrbündelstütze:** Stahlrohre Ø42 mm, Länge 295 cm, feuerverzinkt. **Fachwerkträger:** 4 Stahlrohre Ø20 mm, verschiedene Längen. **Steher in Holz:** Lärchenleimbinder 80x120 mm. **Träger aus Holz:** Lärchenleimbinder 80x160, 80x120 mm. **Streckgitterfüllung:** Streckmetall 1,5 mm, eingefasst mit 2,5 mm Stahlblech. **Rankgitter:** Drahtgitter 4 mm, Maschenweite 50x100 mm. **Pulverbeschichtung:** RAL-Farben nach Wahl. **Befestigung:** zum Einbetonieren oder zum Aufschrauben.

**Supports:** multiple tubular supports Ø42 mm steel tubes, length 295 cm. **Beams:** 4 tubes Ø20 mm; different length available. **Posts in wood:** larch glulam 80x120 mm. **Beams in wood:** Larch glulam 80x160 mm, 80x120 mm. **Panelling:** expanded metal 1,5 mm rounded edging 2,5 mm thick. **Climbing plant lattice:** steel lattice 50x100 mm. **Powder coating:** RAL colour to choose. **Fixation:** fixed in the ground or surface mounting.

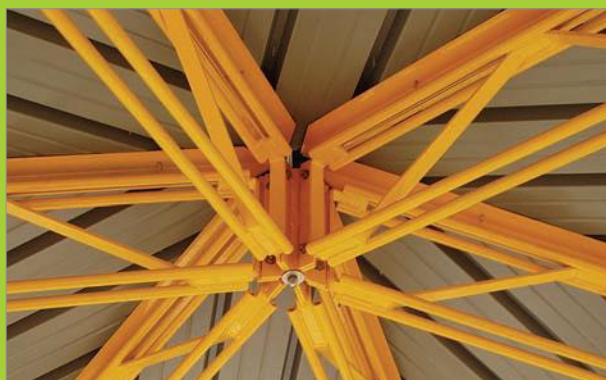

descrizione tecnica e disegni dwg | technische Beschreibung und dwg Zeichnungen | technical description and dwg drawings description technique et dessins dwg: [www.euroform-w.com](http://www.euroform-w.com)







# ecover

copertura fotovoltaica | solardach | couverture photovoltaïque | photovoltaic roofing

energia solare | Solarenergie | energie solaire | solar energy

pannelli fotovoltaici | Solarzellen  
panneaux photovoltaïques | Photovoltaic panels

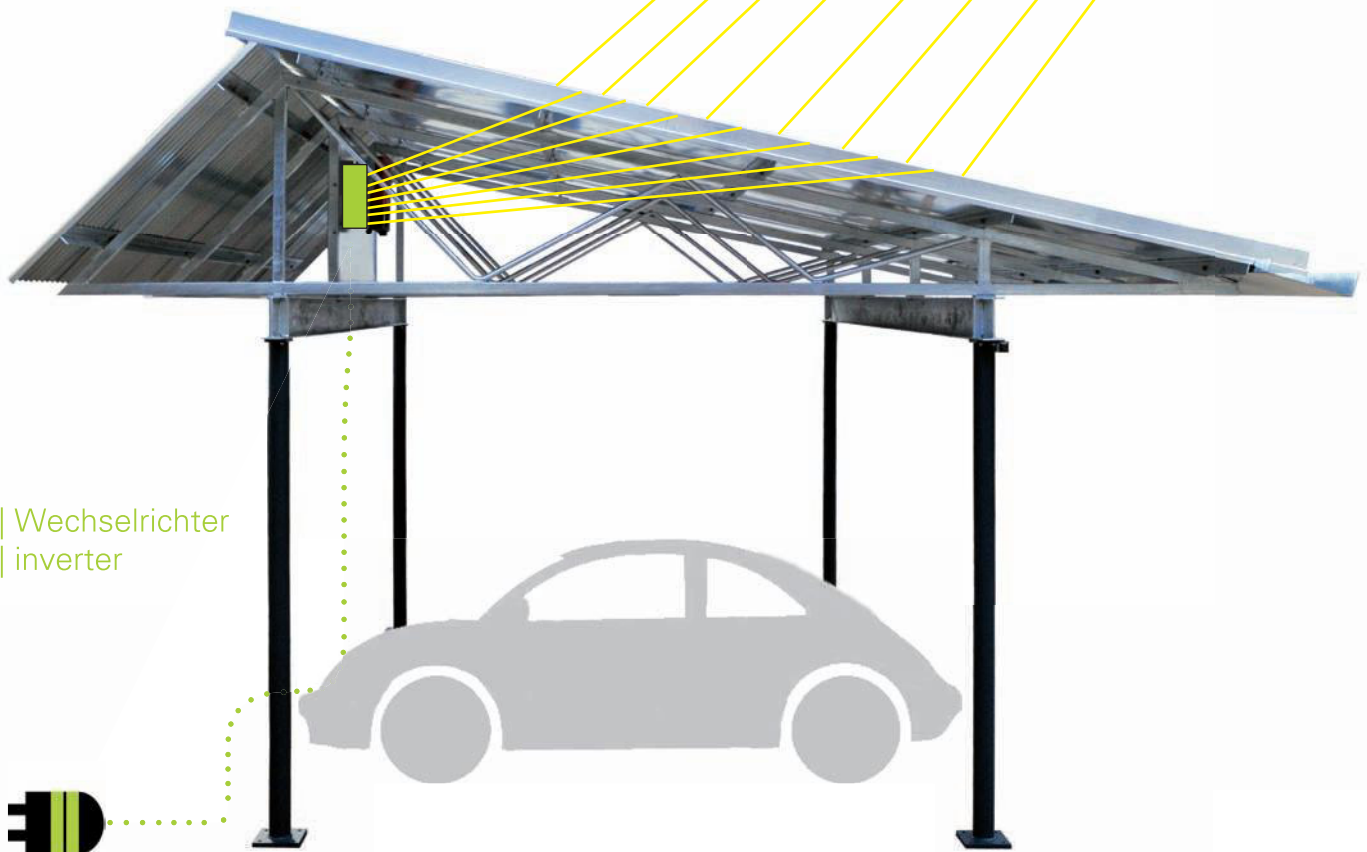

inverter | Wechselrichter  
inverter | inverter

struttura robusta | starke Struktur  
structure robuste | strong structure

energia elettrica riversabile nella rete  
elektrische Energie zur Netzeinspeisung  
énergie électrique réutilisable dans le réseau  
**electric power to deliver to be delivered to the grid**

energy+cover

ecover

sistema di copertura modulare  
modulares Überdachungssystem  
système modulaire de couverture  
modular roofing system

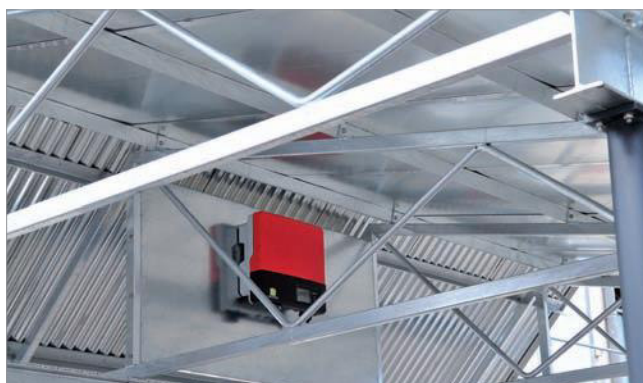

1 anno | Jahr | an | year = -14.000 km

La produzione elettrica annua di un ecover risparmia in Co2 l'equivalente delle emissioni che una macchina produce in 14.000 km!

Mit der jährlichen Energieproduktion „eines“ ecovers wird die gleiche Menge an Co2 eingespart, wie ein PKW bei 14.000 km Fahrleistung ausstößt.

La production électrique annuelle d'Ecover représente une économie en Co2 de l'équivalent des émissions qu'une voiture produit sur 14.000 km!

The yearly power production of one Ecover corresponds to the CO2 produced by a car travelling 14.000 km!

ecover

mod. 3000



ecover

mod. 3010



#### Ecover1 - mod. 3000

**Montanti:** tubo d'acciaio zincato a fuoco Ø101,6 mm.  
**Struttura portante:** travi IPE 200 mm e travi a traliccio in tubo rettangolare 40x60 mm. **Trattamento a polvere:** colori RAL su richiesta. **Dimensioni per elemento base:** 6,17x6,10x3,87 m altezza. **Peso complessivo per elemento base incluso pannelli fotovoltaici:** ca. 1.850 kg. **Energia solare per elemento base:** da calcolare.

#### Ecover2 - mod. 3010

Come Ecover1, tranne: **Struttura portante:** tubi rettangolari 160x140 mm. Grondaia in lamiera d'acciaio 2 mm. **Fissaggio:** con profili angolari 70x70 mm.

**Optionals:** integrazione di pannelli laterali in diversi materiali, rete graticola, illuminazione, sensore di prossimità, impianto di ricarica ecc.

#### Ecover1 - mod. 3000

**Montants:** tube d'acier galvanisé à chaud Ø101,6 mm.  
**Structure portante:** traverses IPE 200 mm et à treillis en tube rectangulaire 40x60 mm. **Revêtement:** poudre polyester cuite au four sur demande, RAL à choix. **Dimensions élément de base:** 6,17x6,10x3,87 M. **Poids total élément de base:** ca. 1.850 kg. **Energie solaire pour élément de base:** pour calculer.

#### Ecover2 - mod. 3010

Comme Ecover1, sauf: **Structure portante:** tubes rectangulaires 160x140 mm. Gouttière en acier 2 mm. **Fixation:** avec des profilés d'angles 70x70 mm.

**Options:** Intégration des panneaux solaires dans différentes matières, réseau grill, éclairage, capteur de proximité.

#### Ecover1 - mod. 3000

**Steher:** feuerverzinktes Stahlrohr Ø101,6 mm. **Unterkonstruktion:** IPE-Träger 200 mm und Fachwerkträger aus feuerverzinktem Rechteckrohr 40x60 mm. **Pulverbeschichtung:** RAL Farben auf Anfrage. **Abmessungen pro Element:** 6,17x6,10x3,87 m Höhe. **Gesamtgewicht pro Element inklusiv Solarmodule:** ca. 1.850 kg. **Solarenergie pro Element:** zu berechnen.

#### Ecover2 - mod. 3010

Wie Ecover1, ausser: **Unterkonstruktion:** Rechteckrohre 160x140 mm. Regenrinne aus Stahlblech 2 mm. **Befestigung:** mit Eckprofilen 70x70 mm.

**Optionals:** Integration von Seitenpaneelen in verschiedenen Materialien, Rankgittern, Beleuchtungselementen, Bewegungsmelder, Aufladestationen usw.

#### Ecover1 - mod. 3000

**Posts:** hot-dip galvanized steel tubes Ø101,6 mm. **Load bearing structure:** IPE 200 mm beams and trusses in rectangular tube with section 40x60 mm. **Powder coating:** RAL colours on request. **Dimensions of the basic unit:** 6.17x6.10x3.87 m height. **Overall weight per base unit including photovoltaic panels:** approximately 1.850 kg. **Basic unit solar power rating:** to be calculated.

#### Ecover 2 - mod. 3010

Same as Ecover 1, expect: **Load-bearing structure:** has rectangular tubes section 160x140 mm. Gutters in 2 mm steel sheet. **Fixing:** profiles 70x70 mm.

**Options:** integration of side panels in various materials, mesh, lighting, proximity sensor, recharging equipment etc.



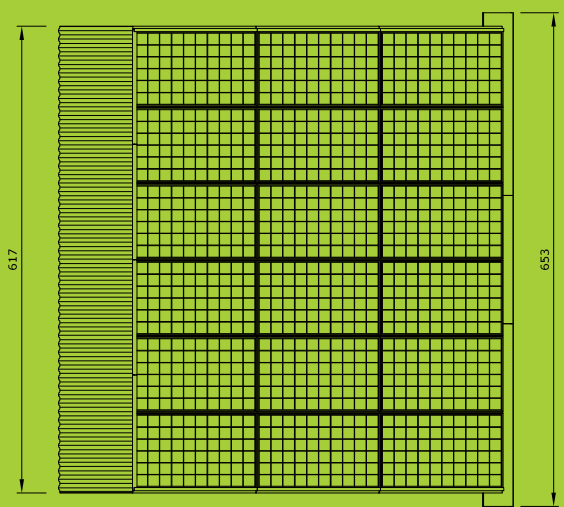
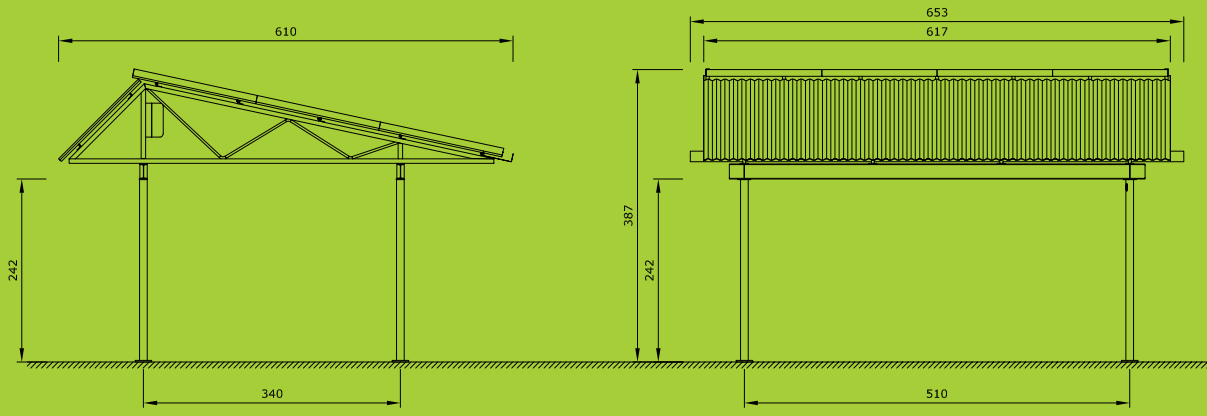

mod. 3000

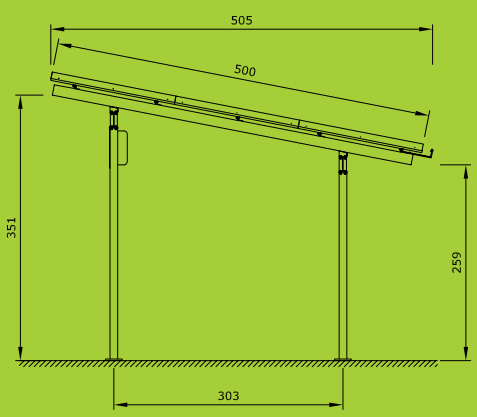
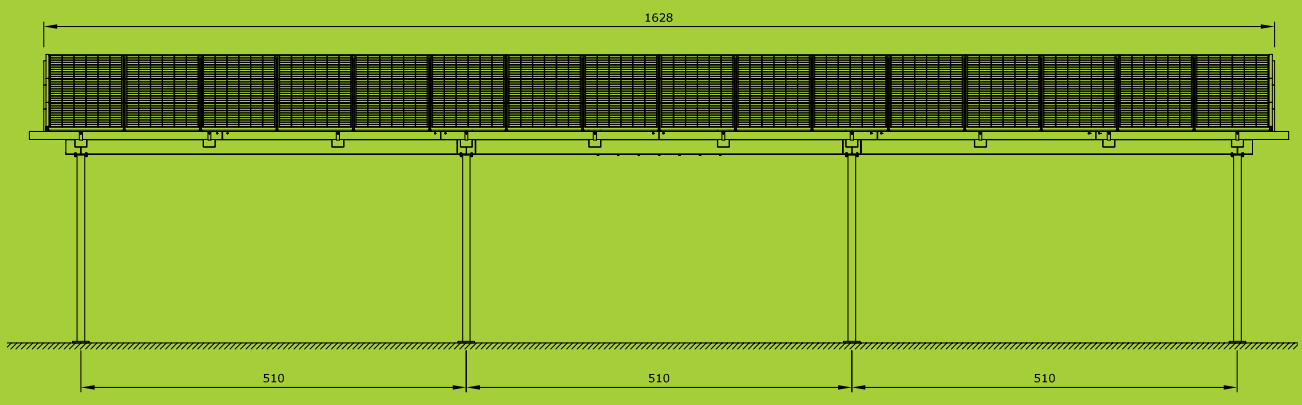

mod. 3010

descrizione tecnica e disegni dwg | technische Beschreibung und dwg Zeichnungen | technical description and dwg drawings description technique et dessins dwg: [www.euroform-w.com](http://www.euroform-w.com)

# general information



# designer

## Arch. Bernhard Winkler

Dal 1973 professore all'Università Tecnica di Monaco (TU). Nel 1955 si è laureato all'Università di Stoccarda nella facoltà di Architettura ed Urbanistica. Winkler ha sviluppato diversi concetti per la limitazione del traffico nei centri urbani – come per esempio a Bologna.

## Arch. Thomas Winkler

1987 – 1989 Mitarbeit im Architekturbüro Prof. B. Winkler

1989 Gründung Architekturbüro Thomas Winkler. Das Tätigkeitsfeld beinhaltet im wesentlichen Projekte im öffentlichen Raum in den Bereichen Hochbau, Städtebau und Freiflächengestaltung. Ergänzend zu seiner Arbeit als Architekt sind Entwicklung und Design von Elementen für den Aussenraum ein wichtiger Bestandteil seines Schaffens.

## Arch. Gherardo Pertile

Gherardo Pertile ha svolto attività didattica presso l'IUAV (Istituto Universitario di Architettura di Venezia) ed è stato visiting teacher presso la Parsons School of Design NY USA e presso la sezione italiana della University of Florida di Vicenza. Si occupa principalmente dell'architettura, del design e dell'urbanistica per trovare soluzioni di comfort ambientale e risparmio energetico.

## Arch. Olivier Scheffer

Ha studiato Urban Design a Utrecht in Olanda. Ha lavorato come designer urbano in diversi uffici a Rotterdam, specializzati in pianificazione di spazi urbani e design di elementi di arredamento urbano. Come designer di elementi per l'arredo urbano gli piace soprattutto scoprire delle linee naturali. Il suo obiettivo è quello di rendere gli elementi urbani che sembrano appartenere al loro ambiente.

Seit 1973 Professor an der Technischen Universität München. Studienabschluss 1955 an der Fakultät für Architektur und Stadtplanung der Universität Stuttgart. Winkler hat diverse Konzepte für die Verkehrsbeschränkung in Stadtzentren entwickelt, wie zum Beispiel das weltweit berühmte Projekt von Bologna.

1987 – 1989 collaborazione presso lo studio di Architettura Prof. B. Winkler. 1989 Fondazione dello studio di Architettura Thomas Winkler. Winkler ha sviluppato diversi progetti per piazze pubbliche, per l'edilizia, pianificazioni urbanistiche ed arredo urbano. In aggiunta al suo lavoro quotidiano di architetto è principalmente coinvolto nello sviluppo e nel design di elementi per l'arredo esterno.

Arch. Pertile war Professor an der IUAV (Istituto Universitario di Architettura di Venezia), sowie Gastdozent an der Parsons School of Design NY USA und an der University of Florida di Vicenza. Arch. Gherardo Pertile beschäftigt sich vorwiegend mit der Architektur, dem Design und der Städteplanung, um komfortable und energiesparende Lösungen zu finden.

Studium Freiraum in Utrecht/Holland. Er arbeitete als Freiraumplaner in verschiedenen Büros in Rotterdam, welche in der sich auf die Planung von öffentlichen Freiräumen und auf die Entwicklung von Freiraumelementen spezialisiert haben. Als Designer von Freiraumelementen inspirieren ihn vor allem natürliche Linien, welche sich in den öffentlichen Raum integrieren.

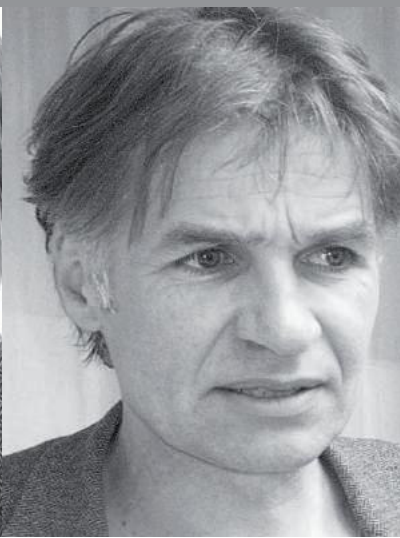
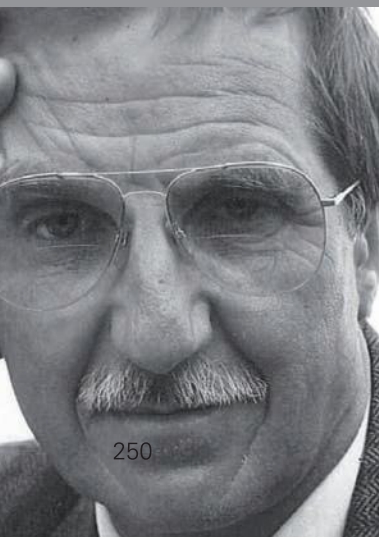

Professeur à l'Université technique de Munich (TU) depuis 1973. Il a obtenu son diplôme à l'Université de Stuttgart, faculté d'Architecture et d'Urbanisme, en 1955. Winkler a développé plusieurs concepts pour limiter la circulation dans les centres urbains, comme par exemple à Bologne.

1987 -1989 Collaboration dans le bureau d'architecture du Prof. B. Winkler 1989 – Création du bureau d'architecture Thomas Winkler Le domaine d'activités comprend essentiellement des projets de mobilier urbain, d'aménagements d'espaces verts en milieu urbain. En complément à son travail d'architecte, il crée et développe le design des mobiliers d'extérieurs.

Gherardo Pertile était professeur à l'Institut Universitaire Architecture de VENISE, ainsi que doyen d'hôte à l'école de design PARSONS de New-York (USA) et à l'Université de Floride. L'architecte Gherardo Pertile concentre son activité essentiellement sur l'architecture, le design et l'aménagement d'espaces extérieurs pour trouver des solutions.

Il a étudié Urban Design à Utrecht en Hollande. Il a travaillé comme designer urbain dans divers bureaux à Rotterdam, spécialisés dans la planification d'espaces urbains et le design d'éléments de mobilier urbain. En tant que designer d'éléments de mobilier urbain il aime surtout découvrir des lignes naturelles. Son objectif est de faire en sorte que les éléments urbains semblent faire partie intégrante de leur environnement.

Since 1973 professor at Munich Technical University (TU). In 1955 graduated at Stuttgart University, Faculty of Architecture and Town Planning. Winkler has developed a number of projects for the limitation of traffic in city centres – as for example in Bologna.

1987 – 1989 collaboration with Architect Prof. B. Winkler. In 1989 establishment of Thomas Winkler Architecture Office Winkler has developed many projects for public squares, buildings, town planning and urban furnishing. In addition to his daily work as an architect, he is also involved in the design and development of elements for outdoor furnishing.

Gherardo Pertile has taught at the IUAV (Venice University Institute of Architecture) and has been a visiting teacher at Parsons School of Design, NY, USA and at the Italian section of the University of Florida in Vicenza. Gherardo Pertile works in the fields of architecture, design and town planning, with special attention to the aspects of environmental comfort and energy savings.

Olivier Scheffer studied Urban Design in Utrecht in the Netherlands. He worked as a small scale urban designer in several offices in Rotterdam, specializing in detailing of urban space and design of urban elements. As a furniture designer he likes to discover natural lines. His objective is to make urban elements that seem to belong to their environment.



# designer

## Arch. Jari Franceschetto

Laureato in architettura allo IUAV di Venezia nel 2002. Svolge attività di progettazione, ricerca e consulenza strategica. Molti dei suoi lavori hanno ricevuto premi e sono pubblicati da importanti riviste.

Jari Franceschetto machte seinen Universitätsabschluss in Architektur 2002 an der Universität IUAV in Venedig. Seitdem arbeitet er als Architekt in der städtebaulichen und architektonischen Planung, Forschung und strategische Beratung. Viele seiner Projekte erhielten Auszeichnungen und wurden in wichtigen architektonische Zeitschriften veröffentlicht.

## Arch. Monica Betta

Negli anni ha declinato la sua professione verso tematiche sociali, di comunicazione e di sperimentazione. In particolar modo si è specializzata in progetti per utenze fragili, in Healing Gardens, verde terapeutico e ortoterapia. Affianca alla professione l'attività didattica, con interventi sia presso il Politecnico di Milano che alla Scuola Agraria del Parco di Monza.

Im Laufe der Jahre hat sie sich vorwiegend mit soziale, kommunikativen und experimentellen Themen beschäftigt. Insbesondere auf Projekte für schwächere Personen, Healing Gardens, grüne und therapeutische Gartenbau-Therapie. Ausserdem übt sie auch den Lehrerberuf aus, mit Interventionen sowohl an der Politecnico von Mailand, School of Agriculture an der Park von Monza.

## Bram van de Haspel

Ha studiato design presso l'Accademia di Arti Visive di Rotterdam, e Fisica (MSc) presso la Delft University of Technology. Ha iniziato come un product designer nel 1995, dopo essere stata attivo nel campo delle tecnologie sostenibili. Nel 2000 ha iniziato uno studio di architettura, insieme ad un socio, perché le assegnazioni sono diventati sempre più architettonico.

Designstudium an der Hochschule für Bildende Kunst in Rotterdam, und Physik (MSc) an der Delft University of Technology. Er begann als eine unabhängige Produkt-Designer im Jahr 1995, nachdem er auf dem Gebiet der nachhaltigen Technologie aktiv war. Im Jahr 2000 gründete er ein Architekturbüro, zusammen mit einem Mitarbeiter, weil die Aufgaben immer mehr architektonischer Natur waren.

## Dipl. Designer, Dipl. Ing. Albrecht Ecke

Nel 1975 ha studiato elettrotecnica e cibernetica presso il Politecnico di Magdeburgo e nel 1982 design industriale presso l'Accademia d'arte di Berlino. Attualmente lavora come designer di prodotto, ideatore di progetti informativi e architetto di mostre con il suo ufficio eckedesign. I suoi prodotti hanno ricevuto numerosi riconoscimenti nel campo del design. L'obiettivo della sua attività creativa è raggiungere l'armonia tra gli aspetti tecnici, economici ed estetici traducendoli in una forma semplice ma intensa nel segno.

Studierte 1975 an der Technischen Universität Magdeburg Elektrotechnik und Kybernetik und 1982 an der Kunsthochschule Berlin Industriedesign. Er arbeitet mit seinem Büro eckedesign als Produktdesigner, Informationsgestalter und Ausstellungsarchitekt. Seine Produkte wurden mit zahlreichen Designpreisen ausgezeichnet. Sein Entwurfsziel ist die Harmonie technischer, ökonomischer und ästhetischer Aspekte in einfacher, aber zeichnerhafter Gestalt.

Diplômé en architecture à l'IUAV de Venise en 2002, il effectue les activités de conception, recherche et conseil stratégique. Une grande partie de ses travaux ont reçu des prix et sont publiés par d'importantes revues.

Au cours des années, elle a tourné sa profession vers des thématiques sociales, de communication et d'expérimentation. En particulier, elle s'est spécialisée en projets pour utilisations fragiles, en Healing Gardens, jardins thérapeutiques et orthothérapie. Elle associe à son métier l'activité d'enseignement, avec des interventions auprès du Polytechnique de Milan et de l'École Agricole du Parc de Monza.

Il a étudié le design auprès de l'Académie d'Arts Visuels de Rotterdam et Physique (Msc) auprès de la Delft University of Technology. Il a commencé en tant que product designer en 1995, après avoir été actif dans le domaine des technologies durables. En 2000, il a lancé un bureau d'architecture, avec un associé, car les commandes devenaient toujours plus architecturales.

En 1975 il a étudié l'électrotechnique et la cybernétique au Polytechnique de Magdebourg et en 1982 design industriel au sein de l'Académie d'art de Berlin. Il travaille actuellement comme designer de produit, concepteur de projets d'information et architecte d'expositions avec son bureau eckedesign. Ses produits ont reçu de nombreuses récompenses dans le domaine du design. L'objectif de son activité de création est d'atteindre l'harmonie entre les aspects techniques, économiques et esthétiques en les traduisant dans une forme simple mais intense comme signe.

Since 1973 professor at Munich Technical University (TU). In 1955 graduated at Stuttgart University, Faculty of Architecture and Town Planning. Winkler has developed a number of projects for the limitation of traffic in city centres – as for example in Bologna.

1987 – 1989 collaboration with Architect Prof. B. Winkler. In 1989 establishment of Thomas Winkler Architecture Office Winkler has developed many projects for public squares, buildings, town planning and urban furnishing. In addition to his daily work as an architect, he is also involved in the design and development of elements for outdoor furnishing.

Gherardo Pertile has taught at the IUAV (Venice University Institute of Architecture) and has been a visiting teacher at Parsons School of Design, NY, USA and at the Italian section of the University of Florida in Vicenza. Gherardo Pertile works in the fields of architecture, design and town planning, with special attention to the aspects of environmental comfort and energy savings.

In 1975 he studied electrical engineering and cybernetics at the Polytechnic Institute of Magdeburg and in 1982 industrial design at the Academy of Art of Berlin. He currently works as a product designer, creator of information projects and exhibition architect with his studio eckedesign. His products have received several awards in the field of design. The goal of his creative endeavour is achieving harmony between technical, economic and aesthetic aspects, translating them into a simple but sign-intense form.

# concrete dimensions

misure per basamenti in cemento | masse für betonfundamente | dimensions des en béton | measurements for concrete basements

Oltre all'estetica, all'ergonomia ed alla durata, "euroform w" dà sempre molta importanza alla praticità. Essa si ottiene da un lato grazie all'utilizzo di materiali di elevata qualità ed al trattamento ottimale delle superfici e dall'altro grazie ad una struttura straordinariamente robusta, di facile montaggio ed il più possibile a prova di vandali.

## Due parti per un utilizzo ottimale

Tutti gli elementi per l'arredo degli esterni della "euroform w" dispongono di una parte separata a pavimento per l'ancoraggio al terreno. Quest'ideale suddivisione dei prodotti in due parti offre diversi vantaggi:

### a) vantaggi in fase di montaggio

gli ancoraggi al terreno possono essere fissati durante la fase di costruzione - il mobilio vero e proprio viene montato a lavori ultimati senza il rischio di subire danneggiamenti.

### b) vantaggi nel trattamento

se il luogo in cui sono montati deve essere sgomberato, ad es. in una strada o in una piazza per una grande manifestazione, gli elementi possono essere smontati e quindi rimontati.

### c) vantaggi di sostituzione

In caso di gravi danneggiamenti, ad es. in seguito ad urti di automezzi, i prodotti "euroform w" possono essere facilmente sostituiti, senza necessità di sostituire le fondamenta esistenti con evidente risparmio di costi.

Neben Ästhetik, Ergonomie und Langlebigkeit legt „euroform w“ stets großen Wert auf die Anwendungsfreundlichkeit. Erreicht wird diese zum einen durch die Verwendung hochwertigster Materialien und der optimalen Oberflächenbehandlung, zum anderen durch eine Konstruktion, die äußerst robust, montagefreundlich und weitgehend vandalensicher ist.

## Zwei Teile für weitgehend optimales Handling

Alle „euroform w“ Freiraumelemente haben ein separates Bodenteil zur Verankerung im Boden. Diese intelligente Aufspaltung der Produkte in zwei Bestandteile bietet viele Vorteile:

### a) Montagevorteil

Bodenteile können an Baustellen während der Bauphase gesetzt werden – das eigentliche Mobilium wird geschont und erst nach Fertigstellung des Objekts unbeschädigt aufmontiert.

### b) Handlingvorteil

Muss ein Aufstellungsort geräumt werden, z. B. eine Straße oder Platz bei einer Großveranstaltung, so können die Elemente ab- und anschließend wieder aufmontiert werden.

### c) Austauschvorteil

Bei extremer Beschädigung, z. B. durch ein aufgefahrenes Kfz, können die „euroform w“ Produkte einfach ausgetauscht werden. Das bestehende Fundament muss dabei nicht erneuert werden – dies spart Kosten.



Outre l'esthétique, l'ergonomie et la robustesse, la gamme "euroform w" tient également compte de la facilité de montage de ses produits. Cela est possible, d'une part, grâce à l'utilisation de matériaux de première qualité et un traitement optimal des surfaces et, d'autre part, grâce à un assemblage fonctionnel, simple et résistant au vandalisme.

#### Deux éléments pour une manipulation aisée

Tous les produits "euroform w" ont une embase séparée à fixer dans le sol. Ce moyen judicieux de présenter les produits en 2 parties présente de nombreux avantages:

##### a) Le montage

Les éléments de fixation peuvent être scellés dans le sol pendant la durée d'un chantier, le mobilier correspondant n'étant installé qu'après achèvement total des travaux. Le mobilier a ainsi été ménagé durant toute cette période et toute détérioration éventuelle a été évitée.

##### b) Facilité de manipulation

Si un emplacement doit être libéré, comme par exemple lors d'une manifestation, les matériels "euroform w" peuvent être démontés et plus tard re-montés.

##### c) Facilité de remplacement

En cas de dommage important sur un élément des produits "euroform w", l'élément en question peut être remplacé sans problème, sans renouveler le scellement existant, ce qui évite des frais inutiles.

In addition to aesthetics, ergonomics and durability "euroform w" always places great emphasis on practicality. This is achieved in part by using materials of the highest quality and an optimal surface treatment process, and also by the use of a construction design which is extremely robust, easy to assemble and which is as vandal-proof as possible.

#### Two elements for optimum handling

All "euroform w" outdoor products have a separate base element for ground anchorage. This clever separation of the products into two distinct elements offers many advantages:

##### a) Assembly

Base elements can be installed on building sites during the construction phase – the actual seating unit can then be mounted after completion, thus protecting the product from premature damage.

##### b) Handling

If a particular location need to be vacated – a square or street for instance, for the duration of a large event – the elements can be detached and later remounted.

##### c) Replacement

In cases of extreme damage, such as that caused by a car, the "euroform w" products can easily be replaced. The existing foundation need not be reset which in turn saves costs.

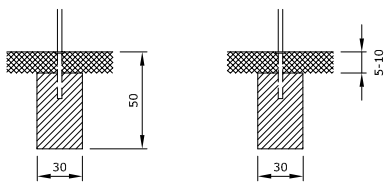
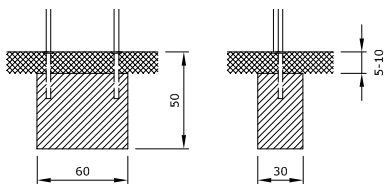
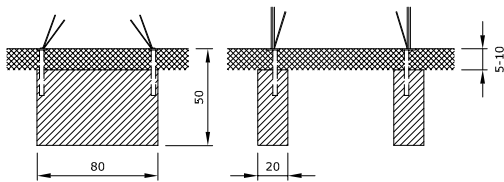
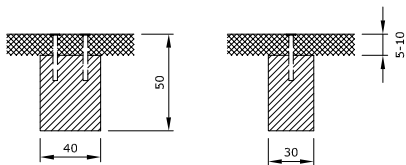
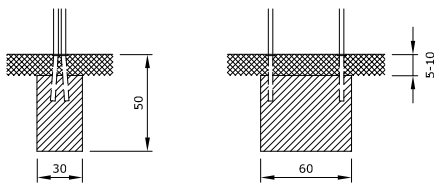
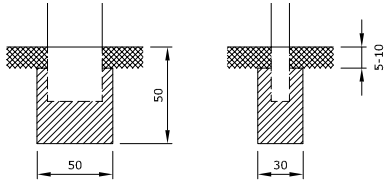
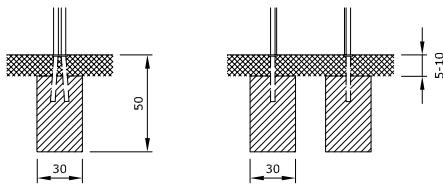

ancora 52  
domino 70  
contour 319-330,  
contour 325/22  
lina 324T-326T  
pic-nic 398  
fun bank 560, 562, 571  
fritz 600  
victor 1200, 1205  
link 1500, 1505  
freebench 4600

simple 270/43, 281  
ing 1650

contour 275, 276, 276/120  
comfort 610, 615, 865, 866  
quattro 860  
eddy 1080  
scala 2010  
zeta 2400, 2405

tulip 230/60, 230/90  
simple+ 2091A

classic 22-33  
mini pic-nic 34, 315, 563  
stilo 35  
palazzo light 48, 49  
palazzo 50  
epoca 51  
ambiente 53, 54, 55  
quattro 83, 85, 86  
block 90, 90L, 90D, 90T  
ortofioriera 6500, 6502

elegance 180, 182, 186  
basic 196  
linea 2040, 2050  
linea light 2040L, 2050L  
infopoint 4430, 4435

economy 71M  
block 99FU, 99FULI, 99FULA  
lina 188  
linea light 188L  
basic 190  
fritz 218  
simple 220V, 221V  
simple light 220VL, 221VL,  
225VL, 226VL  
simple+ 225V, 226V  
lina 293  
barrier 402N, 403N  
fritz 415

linea 420, 425N  
linea light 420L  
lock 460  
linea 900, 901,  
910, 915, 930  
linea light 900L, 901L,  
910L, 915L  
zeta 1490  
nove 4550  
bike rail 4580

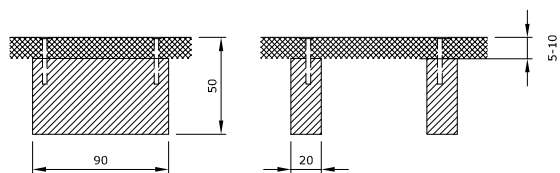

gala 58  
tulip 59, 64M  
quattro 885  
tube 4555, 4560

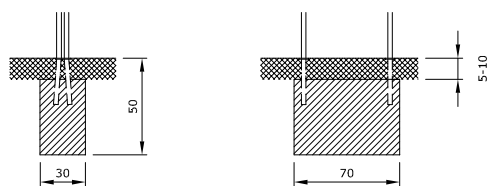

linus 68  
ambiente 272, 273  
comfort 345, 346, 347  
linea 370, 372, 374, 375, 376, 377, 379, 381, 395, 870  
linealight 370L, 272L, 374L, 375L, 376L, 377L, 395L, 870L  
all 1005, 1010, 1025, 1030  
aron 1100, 1105  
zeta 1400, 1402, 1405, 1407, 1410  
band 2600, 2620  
evol 4500  
clip 4512, 4515  
cryou 4520, 4525

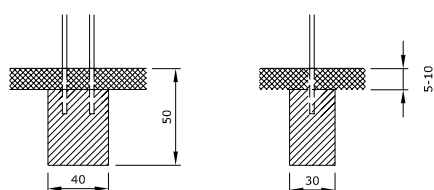

fumée 510, 511  
linea 540  
linea light 540L  
all 1050  
pic-nic 1430, 1435

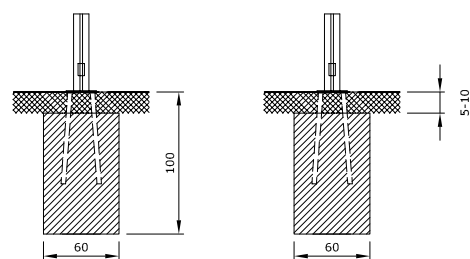

wing 700  
galleria 710, 710D  
light 720, 720D  
combi 740, 740D, 750, 750D  
linea 800

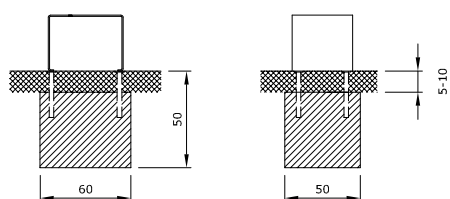

linea 385, 387  
linea light 385, 387L  
drop 3600  
info point 4400, 4405  
mimesi 4530

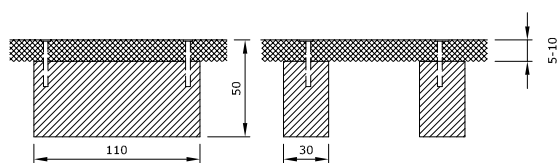

contour 340, 340M  
linea 382  
arco 410  
linea 1305, 1310, 1315, 1325, 1340

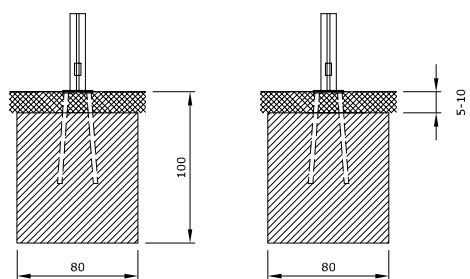

vela 730  
ecover 3000, 3010

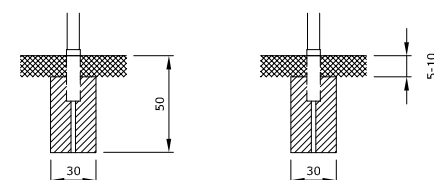

barrier 401H/K, 402H/K, 403H/K

# product index



# Panchine in legno | Bänke in Holz



lineaseduta  
mod. 375  
page 17



lineaseduta  
mod. 377  
page 17



lineapanca  
mod. 370, 372  
page 20



lineasedia  
mod. 374, 376  
page 20



linea  
mod. 387  
page 23



linea  
mod. 1310  
page 23



linea  
mod. 1315  
page 23



linea  
mod. 1310/1325  
page 24



lineapanca light  
mod. 370L  
page 26



lineapanca light  
mod. 372L  
page 26



lineasedia light  
mod. 374L, 376L  
page 29



linea light  
mod. 385L  
page 29



alldouble  
mod. 1010, 1005  
page 32



allrelax  
mod. 1015  
page 32



allbed  
mod. 1025  
page 32



zeta  
mod. 1405  
page 36



link  
mod. 1600  
page 40



movelink  
mod. 1610  
page 40



comfort  
mod. 345, 346, 347  
page 42



contour  
mod. 319S, 319F/S  
page 44



contour  
mod. 324, 324F  
page 47



contour  
mod. 325, 325F  
page 47



contour  
mod. 326, 326F  
page 47



contour  
mod. 327  
page 50

# Bancs en bois | Benches in wood



lineaflex  
mod. 379  
page 21



linea  
mod. 381  
page 20



lineapanca  
mod. 382  
page 20



linea  
mod. 385  
page 23



linea  
mod. 395  
page 24



linea  
mod. 398  
page 24



lineaseduta light  
mod. 375L  
page 26



lineaseduta light  
mod. 377L  
page 26



linea light  
mod. 387L  
page 29



linea light  
mod. 395L  
page 29



allone  
mod. 1010  
page 30



allbench  
mod. 1005  
page 30



zeta  
mod. 1407  
page 36



zetapanca  
mod. 1400  
page 36



zetapanca  
mod. 1402  
page 36



victor  
mod. 1500, 1505  
page 38



contour  
mod. 320S, 320F/S  
page 44



contour  
mod. 321S, 321F/S  
page 44



contour  
mod. 322, 322F  
page 44



contour  
mod. 323, 323F  
page 47



contour  
mod. 328  
page 50



contour  
mod. 329  
page 50



contour  
mod. 330  
page 50



contour  
mod. 332W  
page 52

# Panchine in legno | Bänke in Holz



contour  
mod. 334W  
page 52



contour  
mod. 332M  
page 52



contour  
mod. 334M  
page 52



contour  
mod. 340  
page 56



quattro  
mod. 83  
page 62



quattro  
mod. 85  
page 62



quattro  
mod. 86  
page 62



domino  
mod. 70  
page 66



stilo  
mod. 35  
page 72



stilo  
mod. 35F  
page 72



stilo fitness  
mod. 35P, 35FP  
page 72



block  
mod. 90  
page 74



block  
mod. 99FU, FULi, FULa  
page 76



classic  
mod. 22  
page 80



classic  
mod. 33  
page 80



palazzo light  
mod. 48  
page 82



aron  
mod. 1105  
page 86



linus  
mod. 68  
page 86



# Bancs en bois | Benches in wood



contour  
mod. 325/22  
page 56



ambiente  
mod. 53, 54, 55  
page 58



gala  
mod. 58, 58/10, 58/20  
page 60



gala  
mod. 58D  
page 60



mimesi  
mod. 4530  
page 70



clip  
mod. 4512  
page 70



clip  
mod. 4515  
page 70



cryou  
mod. 4520, 4525  
page 70



block  
mod. 90L  
page 74



block  
mod. 90D  
page 74



block  
mod. 99F, 99FL  
page 76



block  
mod. 99  
page 76



palazzo light  
mod. 49  
page 82



fritz  
mod. 1200  
page 84



fritz  
mod. 1205  
page 84



aron  
mod. 1100  
page 86

# Panchine in ghisa | Bänke in Gusseisen



palazzo  
mod. 50  
page 91



epoca  
mod. 51  
page 91



ancora  
mod. 52  
page 92

# Panchine in metallo | Bänke in Metall



lineaseduta light  
mod. 375LM

page 97



lineapanca light  
mod. 370LM

page 97



linea  
mod. 1305

page 98



linea  
mod. 1340

page 98



contour  
mod. 324M, 324M/F

page 102



contour  
mod. 326M, 326M/F

page 102



contour  
mod. 327M

page 104



contour  
mod. 328M

page 104



gala  
mod. 58M/10

page 110



gala  
mod. 58M/20

page 110



tulip  
mod. 59M

page 113



tulip  
mod. 59M/10, 59M/20

page 113



cadira  
mod. 1960

page 120



cadira  
mod. 1962

page 120



evol  
mod. 4500

page 122



clip  
mod. 4512M

page 122

# Bancs en piètements en fonte Benches in cast iron

## Bancs en métal | Benches in metal



contour  
mod. 319MS+F, 320MS+F,  
321MS+F  
page 98



contour  
mod. 322M, 322M/F  
page 100



contour  
mod. 323M, 323M/F  
page 100



contour  
mod. 325M, 325M/F  
page 100



contour  
mod. 329M, 330M  
page 104



contour  
mod. 340M  
page 106



ambiente  
mod. 53M, 54M, 55M  
page 108



gala  
mod. 58M  
page 110



tulip  
mod. 64M  
page 113



domino  
mod. 70M  
page 114



economy  
mod. 71M  
page 116



fun bank  
mod. 600  
page 118



clip  
mod. 4515M  
page 122



cryou  
mod. 4520M, 4525M  
page 122



free bench  
mod. 4600  
page 124



info point  
mod. 4400, 4405  
page 124

# Acciaio inox | Edelstahl



page 126



# Tavoli | Tische



lineatavolo  
mod. 870  
page 130



lineatavolo light  
mod. 870L  
page 130



zeta pic-nic  
mod. 1400, 1410  
page 132



zeta pic-nic  
mod. 1430, 1435  
page 132



contour  
mod. 324M/T, 326MT  
page 136



mesa  
mod. 1970  
page 139



quattro  
mod. 885  
page 139



block  
mod. 90T  
page 139



venus  
mod. 562  
page 142



pluto  
mod. 571  
page 142

## Table | Tables



alltable  
mod. 1030  
page 134



ing  
mod. 1650  
page 134



contour  
mod. 324T  
page 136



contour  
mod. 326T  
page 136



mini pic-nic  
mod. 315, 34  
page 140



venus mini  
mod. 563  
page 140



info point  
mod. 4400, 4405  
page 141



mercurio  
mod. 560  
page 142

# Cestini portarifiuti | Abfallbehälter



**contour**  
mod. 275H, 276H, 276HA  
**page 146**



**contour**  
mod. 276H/120  
**page 146**



**quattro**  
mod. 860  
**page 146**



**scala**  
mod. 2010, 2010A  
**page 146**



**scala**  
mod. 2010M, 2010M/A  
**page 151**



**band**  
mod. 272, 273, 273A  
**page 151**



**comfort**  
mod. 610, 615  
**page 152**



**comfort**  
mod. 865, 866  
**page 152**



**band**  
mod. 2600  
**page 159**



**simple**  
mod. 270V/43  
**page 159**



**simple**  
mod. 220V, 220W, 220M  
**page 160**



**simple**  
mod. 221V, 221W, 221M  
**page 160**



**simple light**  
mod. 225VL, 225WL, 225ML  
**page 163**



**simple light**  
mod. 226VL, 226WL, 226ML  
**page 163**



**simple+**  
mod. 2090/A  
**page 164**



**simple+**  
mod. 2091/A  
**page 164**

cestini raccolta differenziata  
mülltrennbehälter  
corbeilles de tri sélectif  
waste recycling bin



**band eco**  
mod. 2620  
**page 169**



**ecology**  
mod. 293  
**page 170**

portacenere  
freiraum ascher  
cendries en acier  
ashtrays



**lineafumo**  
mod. 540V, M, B, W  
**page 175**



**lineafumo light**  
mod. 540V/L, B/L  
**page 175**

# Corbeilles | Litter bins



**lineacestino**  
mod. 2040, 2050, 2050A  
**page 148**



**lineacestino light**  
mod. 2040L, 2050L, 2050L/A  
**page 148**



**allcan**  
mod. 1050, 1060  
**page 148**



**zetacestino**  
mod. 2400, 2405  
**page 151**



**contour**  
mod. 275, 275W  
**page 155**



**contour**  
mod. 276, 276A  
**page 155**



**contour**  
mod. 276/120  
**page 155**



**tulip**  
mod. 230/60, 230/90  
**page 156**



**simple+**  
mod. 225V, 225W, 225M  
**page 160**



**simple+**  
mod. 226V, 226W, 226M  
**page 160**



**simple light**  
mod. 220VL, 220WL, 220ML  
**page 163**



**simple light**  
mod. 221VL, 221WL, 221ML  
**page 163**



**fritz**  
mod. 218  
**page 166**



**eddy**  
mod. 1080  
**page 166**

contenitore per deiezione canine  
hundekotbehälter  
corbeilles pour déjections canines  
service container for dogs



**dogy clean**  
mod. 281  
**page 173**



**tumeer**  
mod. 510V, B, M, W, 511V, B, M, W  
**page 176**

# Portabiciclette | Fahrradsysteme



elegance  
mod. 180G + 180A  
page 180



elegance  
mod. 182G + 182E  
page 180



elegance  
mod. 186G, 186E  
page 180



basic  
mod. 190, 190W, 190D  
page 183



lineapalo light  
mod. 420NL  
page 185



lineasosta  
mod. 900, 901  
page 185



lineasosta light  
mod. 900L+ML, 901L+ML  
page 185



lineabici  
mod. 188  
page 186



silhouette  
mod. 185  
page 188

# Sistemi di sbarramento | Absperrsysteme



lineabarriera  
mod. 910  
page 192



lineabarriera light  
mod. 910L  
page 192



lineapalo  
mod. 420N  
page 192



lineapalo light  
mod. 420N/L  
page 192



fritz  
mod. 402N/FR, H/FR, K/FR  
page 199



zeta barriera  
mod. 1490  
page 199



barrier  
mod. 402N+403N, H, K  
page 199



aron  
mod. 950  
page 199



# Rangements pour cycles | Bike systems



basic  
mod. 196  
page 183



basic  
mod. 196L  
page 183



fritz  
mod. 415  
page 183



lineapalo  
mod. 420N  
page 185



lineabici light  
mod. 188L  
page 186



lock  
mod. 460  
page 186



arco  
mod. 410 / 410B  
page 186



bikerail  
mod. 4580  
page 188

# Barrières | Locking systems



lineasosta  
mod. 900, 901  
page 194



lineasosta light  
mod. 900L+ML, 901L+ML  
page 194



linealuce  
mod. 425N  
page 194



lock  
mod. 460  
page 194



arco  
mod. 410, 410B  
page 201



bike rail  
mod. 4580  
page 201



nove  
mod. 4550  
page 201



tube, sittube  
mod. 4555, 4560  
page 201

# Bacheche | Anschlagetafeln



lineaspot  
mod. 915  
**page 204**



lineabachecca  
mod. 930  
**page 204**



lineaspot light  
mod. 915L  
**page 204**



infopoint  
mod. 4430, 4435  
**page 204**

# Fioriere | Bepflanzungssysteme



lineafiore  
mod. 175I, 175II  
**page 210**



lineafiore light  
mod. 175I/L, 175II/L  
**page 210**



lineafiore  
mod. 177  
**page 210**



lineafiore light  
mod. 177L  
**page 210**



ortotavolo  
mod. 6500  
**page 216**



ortofioriera  
mod. 6502  
**page 216**

# Panneau d'affichage | Notice boards



flamingo  
mod. 4570  
**page 206**

---

# Jardinières | Plant systems



cascara  
mod. 130I, II, III, VI  
**page 213**



cascara  
mod. 140I, II, III  
**page 213**



cascara  
mod. 170I, 170II  
**page 213**



pyramid  
mod. 126, 126I  
**page 214**

---

fontane  
brunnen  
fontaine  
fontain



drop  
mod. 3600  
**page 218**

---

# Coperture | Überdachungen



combi  
mod. 740, 750  
page 226



combi  
mod. 740D, 750D  
page 226



galleria  
mod. 710  
page 228



galleria  
mod. 710D  
page 228



wing  
mod. 700D  
page 234



vela  
mod. 730  
page 236

sistemi pergola  
pergolasysteme  
systèmes pergolas  
pergola systems



page 238

copertura fotovoltaica  
solardach  
couverture photovoltaïque  
photovoltaic roofing



ecover  
mod. 3000  
page 246



ecover  
mod. 3010  
page 246

# Couverture | Shelters



light  
mod. 720  
page 230



light  
mod. 720D  
page 230



linea  
mod. 800  
page 232



wing  
mod. 700  
page 234





Italy  
euroform K. Winkler GmbH / srl  
Daimlerstrasse / Via Daimler 67  
I-39032 Sand in Taufers (BZ)  
I-39032 Campo Tures (BZ)  
T +39 0474 678 131  
F +39 0474 678 648

info@euroform-w.it

euroform Partner

