

CARACTERISTICAS / FEATURES

Material hormigón petra 1
Acabado decapado e hidrofugado
Dimensiones l. 170, a. 163, h. 45 cm.
Color ver carta de colores
Fijación simplemente apoyado o mediante resina epoxy
Peso 1930 Kg
Bulto 200 x 200 x 70 cm
Peso bulto 1950 Kg

Material precast concrete petra 1
Finish scaled and waterproofed
Dimensions l. 200, w. 163, h. 45 cm
Colour see colour catalogue
Fixing resting on the ground or with epoxy resin
Weight 1930 Kg
Package 200 x 200 x 70 cm
Weight package 1950 Kg

diseñador / design: La Noche de la Iguana - Kiko Solsona

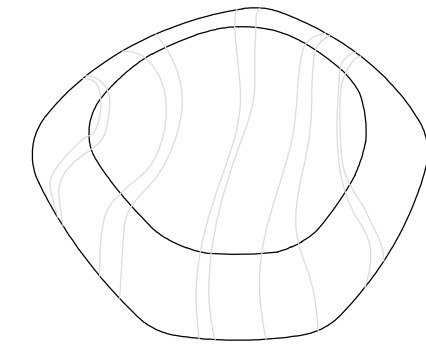

GEOMETRIA / GEOMETRY

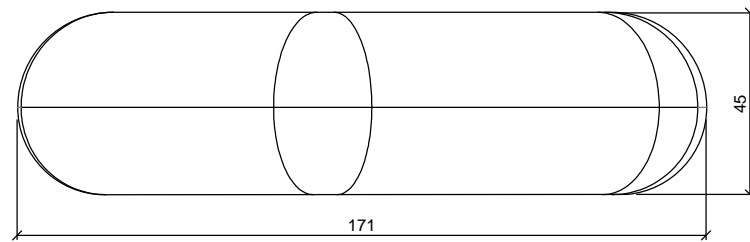

ALZADO / FRONT VIEW

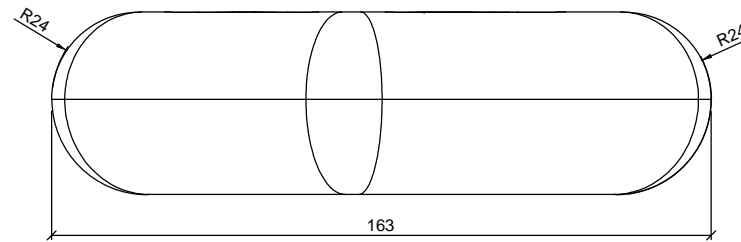

PERFIL / PROFIL VIEW

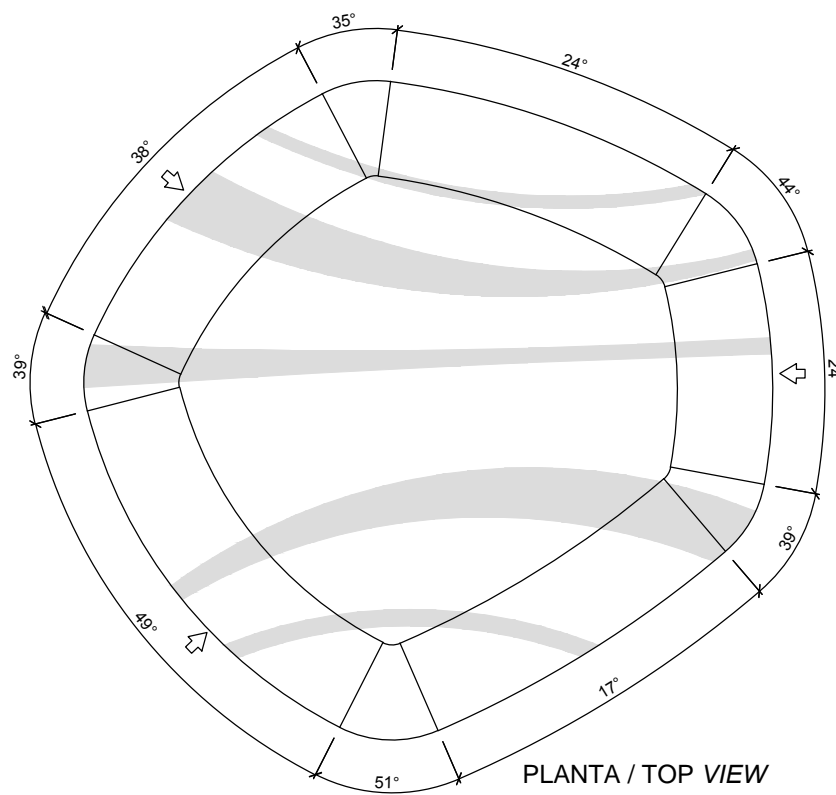

PLANTA / TOP VIEW

↑ ubicación del casquillo roscado
 location of steel socket threaded

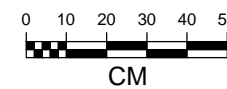

MANIPULACIÓN E INSTALACIÓN / HANDLING AND INSTALLATION

elevación / hoisting
 P= 1260 Kg

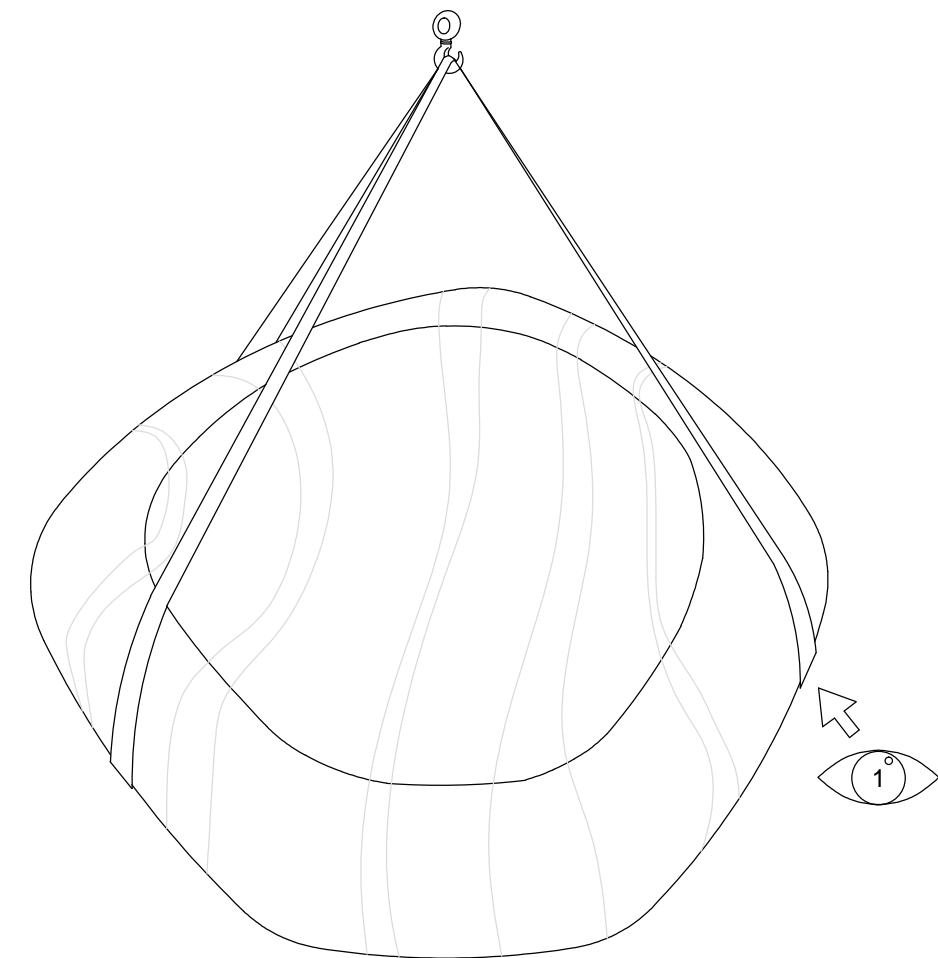

ESPECIFICACIONES / SPECIFICATIONS

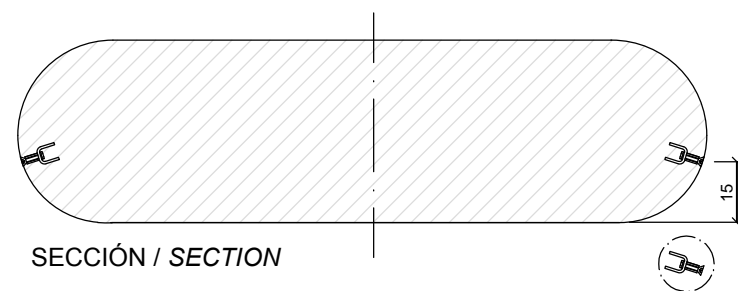

SECCIÓN / SECTION

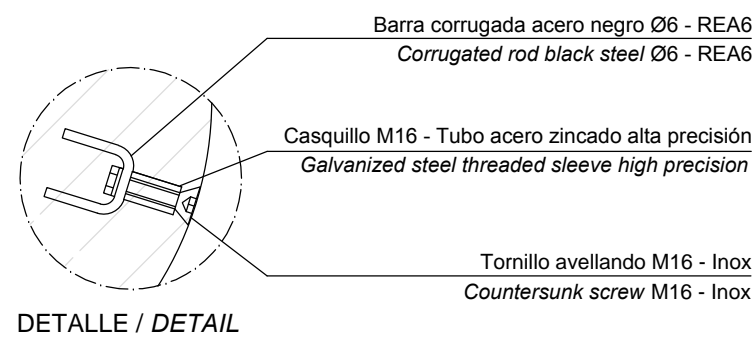

DETALLE / DETAIL

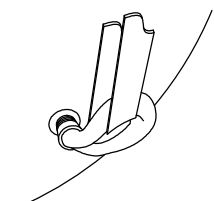
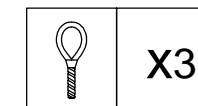

DETALLE 1 / DETAIL 1

Material hormigón petra 1
Acabado decapado e hidrofugado
Dimensiones l. 170, a. 163, h. 45 cm.
Color ver carta de colores
Fijación simplemente apoyado o mediante resina epoxy
Peso 1260 Kg
Bulto 200 x 200 x 70 cm
Peso bulto 1280 Kg

Material precast concrete petra 1
Finish scaled and waterproofed
Dimensions l. 200, w. 163, h. 45 cm
Colour see colour catalogue
Fixing resting on the ground or with epoxy resin
Weight 1260 Kg
Package 200 x 200 x 70 cm
Weight package 1280 Kg

diseñador / design: La Noche de la Iguana - Kiko Solsona

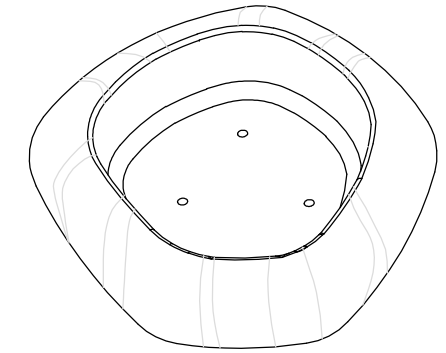

GEOMETRIA / GEOMETRY

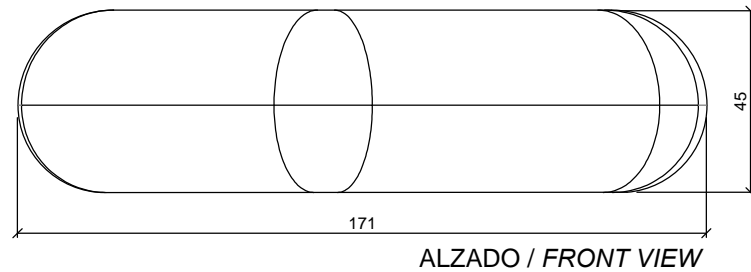

ALZADO / FRONT VIEW

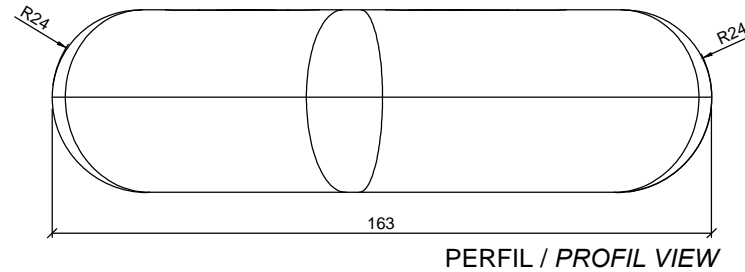

PERFIL / PROFIL VIEW

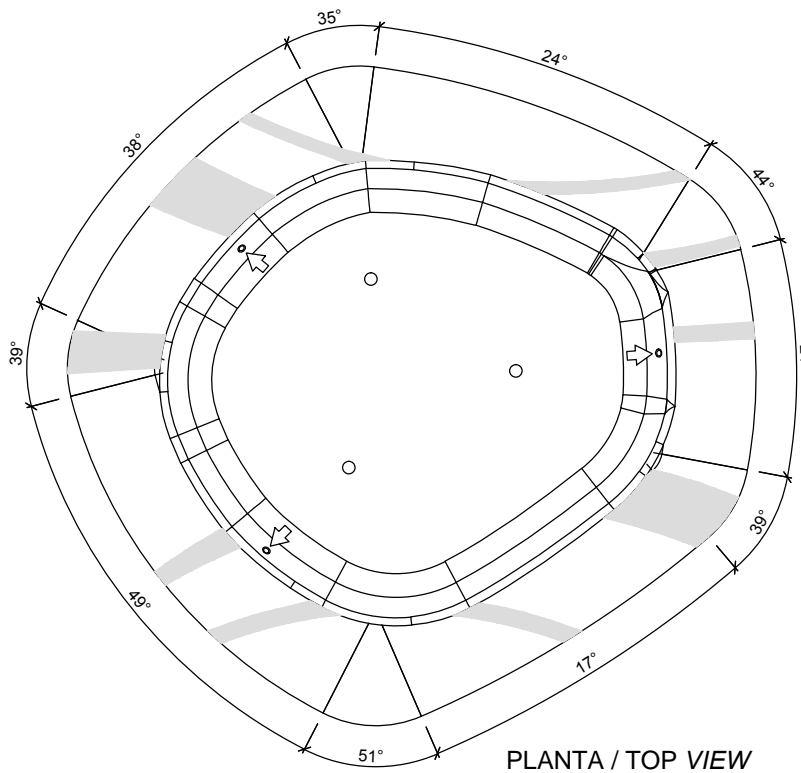

PLANTA / TOP VIEW

↑ ubicación del casquillo roscado
 location of steel socket threaded

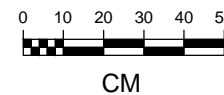

ESPECIFICACIONES / SPECIFICATIONS

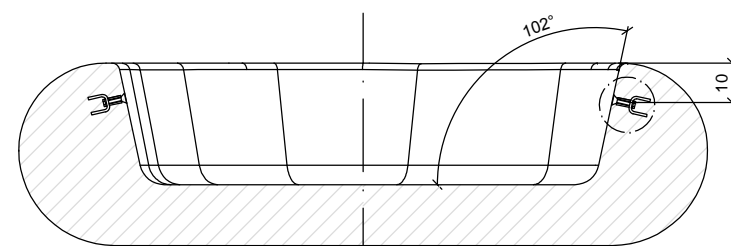

SECCIÓN / SECTION

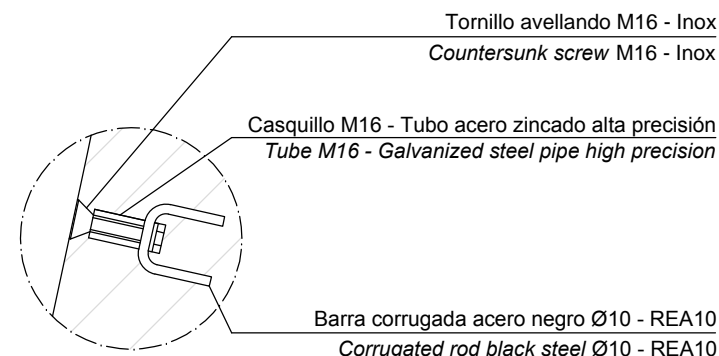

DETALLE / DETAIL

Tornillo avellando M16 - Inox
 Countersunk screw M16 - Inox

Casquillo M16 - Tubo acero zincado alta precisión
 Tube M16 - Galvanized steel pipe high precision

Barra corrugada acero negro Ø10 - REA10
 Corrugated rod black steel Ø10 - REA10

MANIPULACIÓN E INSTALACIÓN / HANDLING AND INSTALLATION

elevación / hoisting
 P= 1260 Kg

